

clever

G R I F E R Í A



Bath & Kitchen

— COLLECTION 2019 —



Grifería Clever nace en 1998 de **Standard Hidráulica S.A.U.**, empresa fundada en Barcelona en 1975 y reconocida como uno de los principales fabricantes de **grifería y accesorios** para **cocina y baño** en **España**. La **calidad**, el **servicio**, la **innovación** y el **exquisito diseño**, unido a una constante **investigación tecnológica** y una cuidada **atención al cliente**, son las bases de la filosofía empresarial de nuestra compañía.

Clever taps was launched in 1998 by Standard Hidraulica, company founded in 1975, well known as one of the most important taps, mixers and showers manufacturers in Spain. Our company's philosophy is based in quality, service, innovation, exquisite design and technology investigation.

Clever est né en 1998 au sein de Standard Hidráulica S.A.U., une entreprise fondée à Barcelone en 1975, et reconnue comme l'un des principaux fabricants de robinetterie pour la cuisine, la salle de bains et les collectivités en Espagne. La qualité, le service, l'innovation et les designs exquis, combinés avec l'intégration constante des nouvelles technologies et le suivi attentif de notre clientèle sont les fondements de la philosophie d'entreprise de notre société.

PLATINUM

Ventu	22
Aude	24
Selene	26
Bimini	28
Marina Evo	34
Saona Slim	36
Paula	38
Nine <i>elegance</i>	42
Nine <i>xtreme</i>	46

STYLES

Agora <i>elegance</i>	52
Agora <i>xtreme</i>	54
Artic <i>xtreme</i>	58
Artic <i>urban</i>	62
Caiman <i>elegance</i>	64
Caiman <i>xtreme</i>	68
Caiman <i>urban</i>	70
With2 <i>Antigona</i>	74
With2 <i>Morea</i>	78

STYLES PRO

Bahama <i>xtreme</i>	84
Habana <i>xtreme</i>	88
Start <i>elegance</i>	92
Start <i>xtreme</i>	96
Start <i>urban</i>	100
NEW Panam Evo <i>elegance</i>	104
Panam Evo <i>xtreme</i>	108
Panam Evo <i>urban</i>	112
Panam <i>urban</i>	118
S12 <i>elegance</i>	122
S12 <i>xtreme</i>	126
S12 <i>urban</i>	130
With2 <i>Guayama</i>	136
Nine <i>urban</i>	140

EQUIPOS PARA CALIDAD DEL AGUA

NEW Viveo	148
Komeo	152
FX04	156

COCINA

NEW Grifería para Calidad del agua <i>Water quality / Qualité de l'eau</i>	162
Abatibles <i>Folding spout / Bec rabattable</i>	166
Chef	168
Platinum	178
Styles	182
Styles Pro	188
Gerontológico <i>Medical lever / Manette médicale</i>	202

HIDROCLEVER

iClever	208
NEW iKansas	218
Rociadores <i>Shower heads / Pommets de douche</i>	220
Brazos rociadores <i>Shower arms Bras pour pomme de douche</i>	225
Conjuntos de ducha <i>Shower kits / Ensembles de douche</i>	226
Barras de ducha <i>Slidings bars / Barres de douche</i>	228
Caños empotrar <i>Bath spouts / Bec</i>	230
Jets Hidromasaje <i>Body jets / Jets</i>	230
Teléfono ducha <i>Handsets / Douchettes</i>	231
Soportes <i>Wall brackets / Supports</i>	235
Flexibles <i>Flexibles / Flexibles</i>	236
Salidas flexo <i>Wall outlets / Sorties flexible</i>	237

GAMA BOX

Termostáticos <i>Thermostatics / Thermostatiques</i>	240
Monomandos <i>Single lever mixers / Mitigeurs</i>	242
Sobremesa <i>Floorstands / Présentoirs</i>	246

ACCESORIOS DE BAÑO

Platinum	250
<i>elegance</i>	252
<i>xtreme</i>	254
<i>urban</i>	256

COLECTIVIDADES

NEW Temporizados <i>Delay action / Temporisés</i>	264
NEW Electrónicos <i>Electronic divises / Électronique</i>	266
Ducha higiénica <i>Shattaf / Douche hygiénique</i>	270
Grifos individuales <i>Cold water taps / Robinets individuels</i>	272
Gerontológicos <i>Medicals / P.M.R.</i>	274

TERMOSTÁTICOS

Termostáticos <i>Thermostatics / Thermostatiques</i>	278
---	-----

SISTEMAS DE DUCHA y BAÑO-DUCHA

Termostáticos extensibles <i>Adjustable thermostatics</i> <i>Thermostatiques extensibles</i>	284
Termostáticos no extensibles <i>Non-adjustable thermostatics</i> <i>Thermostatiques non extensibles</i>	286
Monomandos extensibles <i>Adjustable single lever</i> <i>Mitigeurs extensibles</i>	288
Bimandos extensibles <i>Adjustable two handles</i> <i>Mélangeurs extensibles</i>	290
Monomandos no extensibles <i>Non-adjustable single lever</i> <i>Mitigeurs non extensibles</i>	290

CyR

Complementos y recambios <i>Accessories and spare parts</i> <i>Accessoires et Pièces de rechange</i> ..	292
---	-----

EXPOSITORES

Expositores sobremesa <i>Display stand over-table</i> <i>Présentoirs</i>	310
Clever Maxi	312

OFF CLEVER

Mikura	320
Saona	321
Marina	322
Artic <i>urban</i>	323
Caiman <i>elegance</i>	323
Caiman <i>urban</i>	323
With2 <i>morea</i>	324
Bahama <i>urban</i>	325
Panam <i>elegance</i>	326
Panam <i>xtreme</i>	328
Nine <i>urban</i>	330
Temporizados <i>Delay action / Temporisés</i>	330
Chef	331

INFORMACIÓN

Información técnica <i>Technical information</i> <i>Information technique</i>	334
Certificados <i>Certificates / Certificats</i>	346
Índice de referencias <i>Item directory</i> <i>Index des références</i>	350
Condiciones de venta <i>Sales conditions</i> <i>Conditions a vendre</i>	356

NEW

NOVEDADES

News / Nouveautés

Nuevos acabados

New finishes / Nouvelles finitions



Acabado en blanco MATE.

Matt white finish.

Finition blanc mat.



Acabado en negro MATE.

Matt black finish.

Finition noir mat.



Nine **xtreme**

PÁG.48

Disponible en Abril de 2019

Available in April 2019 / Disponible en Avril 2019

LEO Quick-clac

PÁG.297



Agora **xtreme** PÁG.54



Start **elegance** PÁG.92



RENOVAMOS EL DISEÑO SIN PERDER LA ESENCIA

We renew the design without losing its essence / Nous rénovons le design, sans perdre l'essence

#thePanamEvolution



Panam Evo *elegance*
PÁG.104



Panam Evo *xtreme*
PÁG.108



Panam Evo *urban*
PÁG.112

NOVEDADES



News / Nouveautés

Nuevos temporizados con sistema auto-limpiable y mayor durabilidad

cosedal

PÁG.264

New delay action with self-cleaning system and greater durability

Nouveau robinet temporisé avec système d'auto-nettoyage et une plus grande durabilité

- ✓ Cartucho auto-limpiable.
Self-cleaning cartridge. / Cartouche autonettoyante.
- ✓ Aireador enrasado y antivandálico
*Fitted and anti-vandalism aerator.
Aérateur caché et anti-vandalisme.*
- ✓ Filtro antipartículas integrado en la entrada de agua.
*Antiparticles filter integrated into the water inlet.
Filtre anti-particules intégré dans l'entrée d'eau.*



Disponible a partir de Septiembre 2019 / Available from September 2019 / Disponible à partir de Septembre 2019

Nueva grifería electrónica

New electronic taps

Nouveaux robinets électroniques



PÁG.266

- ✓  **Sensor antivandálico a los 55 segundos**
*Anti-vandalism sensor at 55 seconds
Cellule électrovanne anti-vandalisme
calibrée à 55 secondes*

- ✓ **Aireador antivandálico**
*Anti-vandal aerator
Aérateur anti-vandalisme*

Platinum



elegance

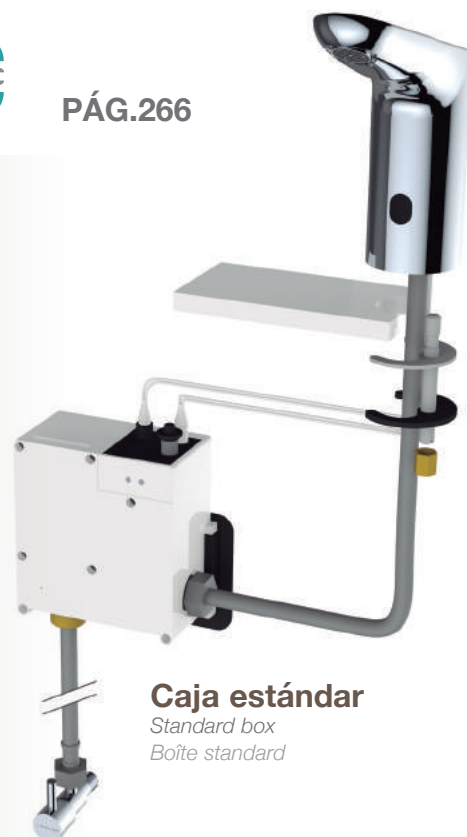

Caja estándar
*Standard box
Boîte standard*

Mejora importante de la higiene y el confort

Important improvement of hygiene and comfort / Amélioration importante de l'hygiène et du confort

Disponible en Abril de 2019 / Available in April 2019 / Disponible en Avril 2019

NEW

NOVEDADES

News / Nouveautés

Nuevo iclever box

New iclever box / Nouvelles iclever box

PÁG.244



Nuevas barras de ducha empotradas

New concealed sliding bar / Nouvelles barre de douche escastré

Trend / City
PÁG.228



COMAP

viveo

Unidad de calidad del agua para la cocina

Smart water ultrafiltration unit for the kitchen

Équipement d'ultrafiltration pour la qualité de l'eau de la cuisine



Disponible a partir del 2º semestre 2019

Available from 2nd semester 2019 / Disponible à partir du 2ème semestre 2019

PÁG.148

NOVEDADES



News / Nouveautés

Nuevo grifo semiprofesional para equipos de **Calidad del agua**

*New drinking water sink mixer
Nouveau mitigeur évier avec sortie eau purifiée*

Chef WT 19 PÁG.162

Mantenemos el **diseño** de las **Chef**, pero más funcional con **3 vías**.

*We maintain the Chef design, but more useful with its 3 ways
Nous maintenons le design des mitigeurs évier CHEF, mais en le rendant plus fonctionnel grâce à ses 3 voies.*

Disponible en Abril de 2019
Available in April 2019 / Disponible en avril 2019



Salida de agua mezclada
Mixed water outlet - Sortie d'eau mitigée du réseau



Salida de agua filtrada
Filtered water outlet - Sortie d'eau purifiée

Nuevo grifo de cocina **Abatible** para equipos de **Calidad del agua**

*New drinking water sink mixer with folding spout
Nouveau mitigeur à bec rabattable et orientable avec sortie pour eau purifiée*

Chef FS 19 PÁG.163

Agua mezclada y Agua filtrada desde una sola maneta

*Mixed and filtered water on the same handle
Eau du réseau et eau purifiée depuis une seule manette*

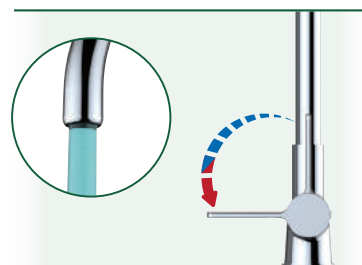

Salida progresiva de agua mezclada
Progressive mixed water outlet
Sortie d'eau progressive de froid à chaud



Salida de agua filtrada
Filtered water outlet - Sortie d'eau purifiée

Disponible en Abril de 2019
Available in April 2019 / Disponible en avril 2019

La excelencia en el proceso de fabricación

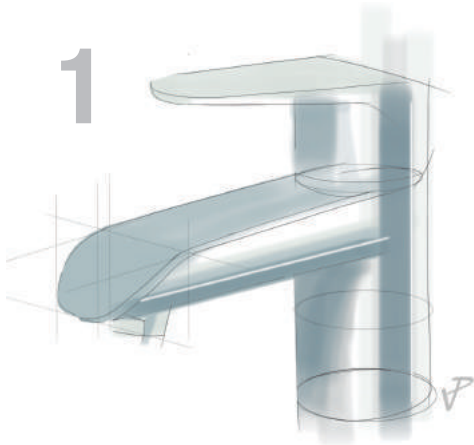

1
Diseño
Design | Design

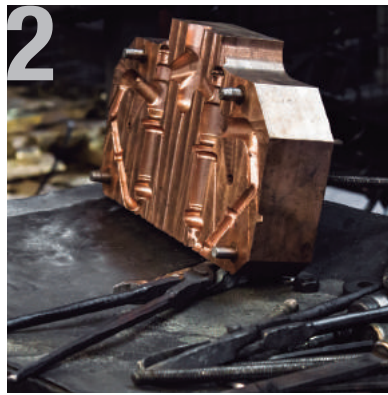

2
Moldes
Molds | Moules



3
Fundición
Casting | Fonte



7
Cromado
*Chrome plating
Chromage*



8
Montaje
*Assembly
Assemblage*



9
Control de calidad
*Quality control
Contrôle de qualité*

The excellence in the manufacturing process
L'excellence dans le processus de fabrication



4
Extracción noyo arena
Sand core pullers extraction
Extraction des noyaux de sable

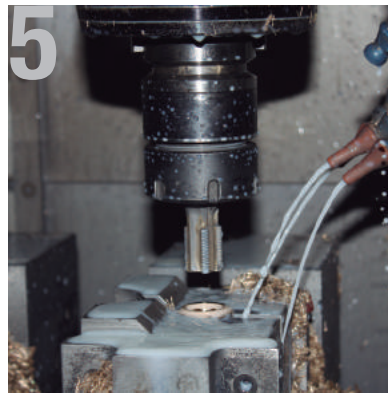

5
Mecanizado
Machining / Usinage

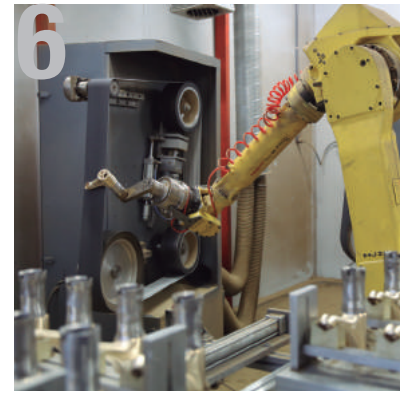

6
Pulido
Polishing / Polissage



10
Certificados
Certificates
Certificats



11
Embalaje
Packaging
Emballage



12
Producto instalado
Installed product
Produit installé

La tecnología más avanzada en grifería

The most advanced technology in taps and showers
La technologie la plus avancée dans les robinets



Cartucho distribuidor cerámico
Ceramic cartridge distributor
Cartouche dérivateur céramique

gitec

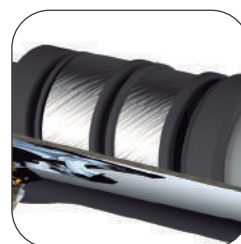

Cartucho termostático sensor Vernet fabricado según EN 1111
Thermostatic cartridge (EN 1111)
Cartouche thermostatique (Norme EN 1111)

Vernet

cosedal
THE FAUCET'S HEART

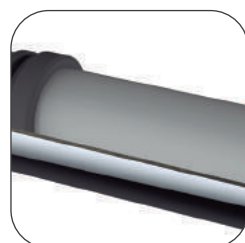
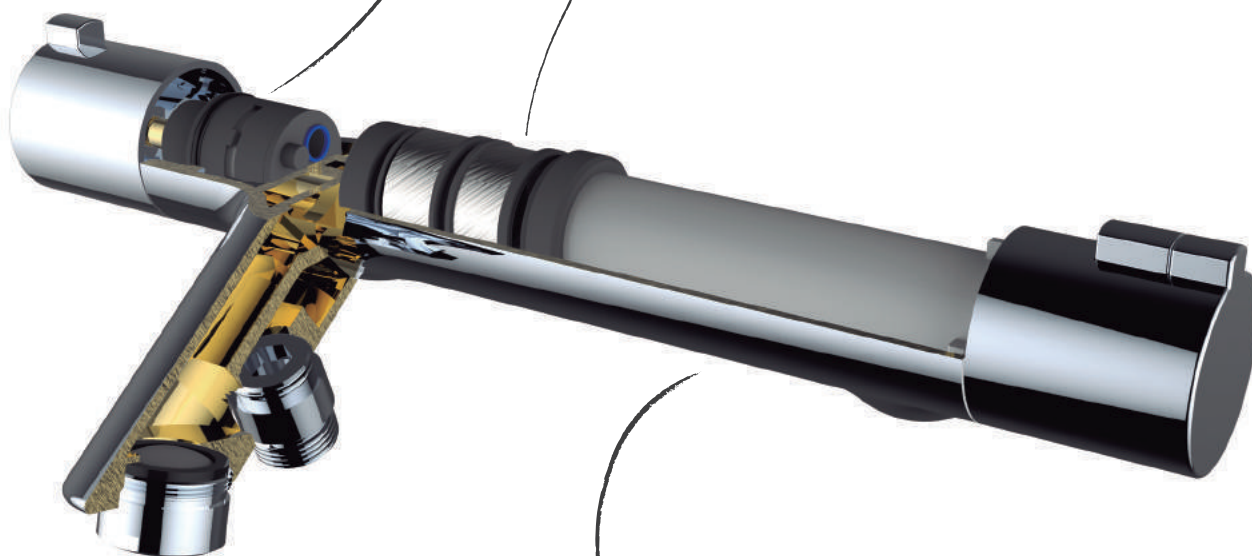

Cold Touch System patentado
Cold Touch system patented
Système Cold Touch breveté

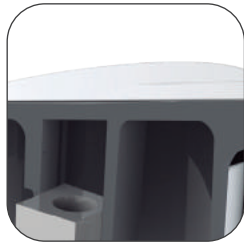

Proceso de cromado compuesto por 44 pasos, máxima resistencia a la corrosión

Chroming process comprising 44 steps, high corrosion resistance

Le processus de chromage comprends 44 étapes, pour une résistance maximale à la corrosion

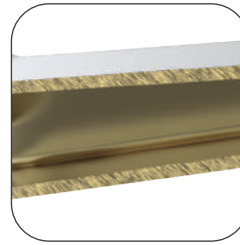

Bajo porcentaje de plomo
Cu 60% +0,5. Pb<1,6%

*Low percentage of lead
60% Cu + -0.5. Pb <1.6%*

*Faible pourcentage de plomb
60% Cu + -0,5. Pb <1,6%*



EPDM/PEX. Certificación AENOR y CSTBat. Fabricados según norma UNE EN 13618

EPDM / PEX. AENOR and CSTBat certification. (UNE EN 13618)

EPDM / PEX. Certification AENOR et CSTBat. (Norme ENE EN 13618)



Aireadores de última generación
Aerators new generation
Aérateurs de nouvelle génération

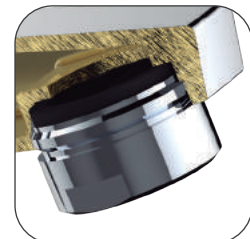

Cartuchos con cerámicas de alta precisión. Fabricados para superar UNE EN 817

Ceramic cartridges with highly precision. (UNE EN 817)

Cartouches céramiques de grande précision. (Norme UNE EN 817)



CÓMO AHORRAR AGUA EN CASA CON clever

Descubre los beneficios de EcoCLEVER
Nuestra tecnología en los cartuchos **ec2** (Econature), **ec3** (Econature+Coldopen) y **Tech Air** (Agua+Aire) está diseñada especialmente para obtener un uso sostenible en el que se evita el gasto innecesario de agua y energía.

VIVENDA TIPO



4 personas que componen el hogar



5,8 min uso aproximado de la grifería por persona/día



0,0014 €/L
coste agua fría



0,0052 €/L
coste agua caliente

¿CÓMO LO CALCULAMOS?

$$4 \times 5,8 = 23,2 \text{ min al día} \rightarrow 334 \text{ litros al día}$$

integrantes de la casa min de agua por persona



$$334 \times 365 = 121.910 \text{ litros al año} \rightarrow 521€ \text{ al año}$$

coste de agua/grifería (lavabo, ducha y cocina)



$$213 \times 365 = 77.745 \text{ litros al año}$$

litros de agua por familia
70% agua caliente / 30% agua fría

339€ al año
coste de agua/grifería (lavabo, ducha y cocina) → **AHORRO 35%**



$$213 \times 365 = 77.745 \text{ litros al año}$$

litros de agua por familia
50% agua caliente / 50% agua fría

309€ al año
coste de agua+energía/grifería (lavabo, ducha y cocina) → **AHORRO 41%**

Tiempo de uso grifería: min/persona/día

LAVABO	2,4
DUCHA	2,8
COCINA	0,6

Total 5,8

Tabla de consumos

	L(agua)/min
CONSUMO DUCHA	18
CONSUMO DUCHA TECH AIR	12,6
CONSUMO LAVABO EC1	11
CONSUMO LAVABO EC2	6
CONSUMO LAVABO EC3	6
CONSUMO GRIFO COCINA EC1	11
CONSUMO GRIFO COCINA EC2	6
CONSUMO GRIFO COCINA EC3	6

Los resultados de esta infografía son en base a la tabla de consumos litro de agua por minuto y aplicando solo las variables de grifería para lavabo, ducha y cocina.

Fuente: CTEHS4

CLEVER trabaja con su departamento de I+D para obtener griferías que ahorren agua y energía en nuestro uso diario. Gracias a nuestros cartuchos, aireadores y limitadores de caudal, diseñados especialmente para obtener un uso sostenible, es posible ahorrar agua y cuidar el planeta.

CLEVER is always improving with its R+D department to obtain taps perfectly designed to save water and energy in our daily use.

CLEVER travaille avec son département de R&D pour obtenir une robinetterie qui permet l'économie d'eau et d'énergie au quotidien.

Grâce à nos cartouches, mousseurs et limiteurs de débit, conçus spécialement pour une utilisation durable, il est possible d'économiser l'eau et de prendre soin de notre planète.

Cartuchos

Cartridges / Cartouches

ec2 Sistema EcoNature

Ahorro de agua **C2** 

Save water / Économie d'eau

Dos posiciones de apertura de la maneta.

Two positions of opening the handle.

Deux positions d'ouverture de la poignée.



ec3 Sistema EcoNature+Cold Open

Ahorro de agua y energía **C3** 

Save water and energy / Économie d'eau et d'énergie

El grifo se abre siempre con agua fría. En la posición central de la maneta se evita la mezcla de agua fría y caliente.

The tap always opens with cold water. In the central position of the handle the mixing of cold and hot water is avoided.

Le robinet s'ouvre toujours avec de l'eau froide. Dans la position centrale de la poignée, le mélange d'eau froide et d'eau chaude est évité.



Tech AIR

AIR Technology / Technologie AIR

Los teléfonos y rociadores Clever usan la tecnología AIR Advanced. Inyectando aire antes de la salida del agua, se consigue dar volumen a las gotas reduciendo el consumo de agua hasta un 30%.

Clever Hand showers and Rain showers use the advanced technology AIR Advanced. Mixing air with the incoming water reduces the water consumption at least 30%.

Les douchettes et les pommes de douche Clever sont équipées de la technologie AIR Advanced la plus avancée. L'injection d'air avant la sortie d'eau permet de donner du volume aux gouttes et permet aussi d'économiser jusqu'à 30% de consommation d'eau.



Aireadores

AIR Technology / Technologie AIR



Mezcla aire/agua variable

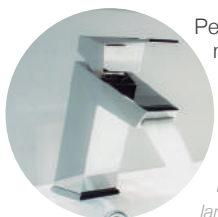

Permite que el usuario escoja el grado de mezcla aire/agua que necesita sin limitador de caudal.

Allows the user to choose the necessary mixing level air/water without using a flow limiter.

Permet à l'utilisateur de choisir la proportion de mélange air/eau dont il a besoin sans limiteur de débit.

Límite de caudal máximo



Permite limitar el caudal máximo, independientemente de la posición de la maneta, consiguiendo así un mayor ahorro de agua. (No recomendable para grifería de bañera)

To limit the maximum flow rate regardless the handle position, saving more water. (it is not recommended for bath mixers)

Permet de limiter le débit maximum indépendamment de la position de la poignée, obtenant ainsi une économie d'eau supplémentaire (non recommandé pour la robinetterie de baignoire).

¿Qué significa cada certificación?

¿What's the meaning of each certification?

¿Que signifie chaque certification?

1 Adhesión del revestimiento sobre materiales plásticos, choque térmico

Lining adhesion on plastic materials, thermal shock.
Adhésion du recouvrement sur les matériaux plastiques, choc thermique.

Ensayar la adhesión del cromo a los materiales plásticos de la grifería mediante choques térmicos.

Testing the Chrome adhesion on the plastic materials by thermal shocks.

Test d'adhésion du chrome sur les éléments plastiques de la robinetterie par choc thermique.

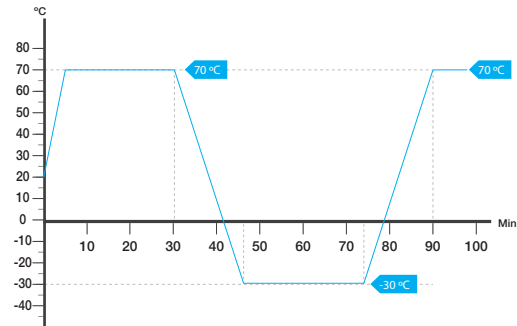

2 Resistencia, niebla salina

Resistance. Salt spray test
Résistance, brouillard salin/acétique

Ensayar la resistencia de los materiales metálicos de la superficie cromada mediante 200 horas bajo el efecto de la niebla salina.

Test the Chrome resistance surface on the metallic materials by checking them on the salt spray test during 200 hours.

Test de durabilité de la surface chromée des éléments métalliques par exposition de 200 h à un brouillard salin.

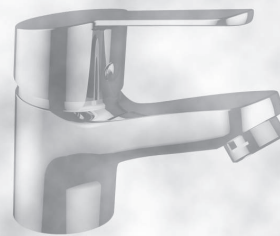

200h

5% Sal
Salt | Sel

Solución salina 64
con 5% NaCl
Saline 64 with 5% NaCl
Solution saline 64 sur
5% NaCl.

3 Duración mecánica

Mechanic Duration
Durabilité mécanique

Ensayar la duración mecánica de las partes móviles mediante ciclos enteros en **cartuchos, caños e inversores**.

Test the duration of the mechanical moving parts by cycles on the cartridges, spouts and diverters.

Test d'endurance mécanique des éléments mobiles, cartouches, becs et inverseurs.

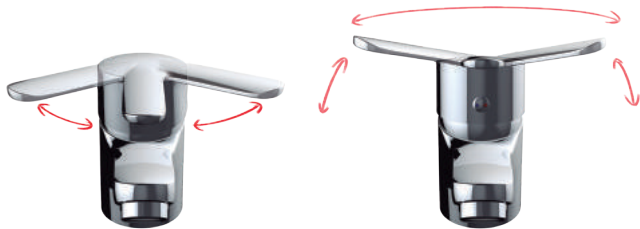

Cartucho / Cartridge / Cartouche

70.000

Caño / spout / bec

80.000

Inversor / diverter / inverseur

30.000



Cartucho / Cartridge / Cartouche

175.000

Caño / spout / bec

200.000

Inversor / diverter / inverseur

80.000

4 Resistencia a la presión

Resistance on the pressure
Résistance à la pression

Ensayar la resistencia a la presión sometiendo al cartucho y la grifería un tiempo determinado a una cierta presión

Test the pressure resistance subjecting the cartridge and the mixers during a certain time to a particular pressure.

Test de résistance à la pression en soumettant l'ensemble cartouche/robinet pendant une période de temps déterminé à certaines pressions.



Tiempo / Time / Temps

60s

Presión / Pressure / Pression

25 bars

Repeticiones / Repétitions / Répétitions

100

Presión / Pressure / Pression

50 bars



Proyectos

Projects / Projects

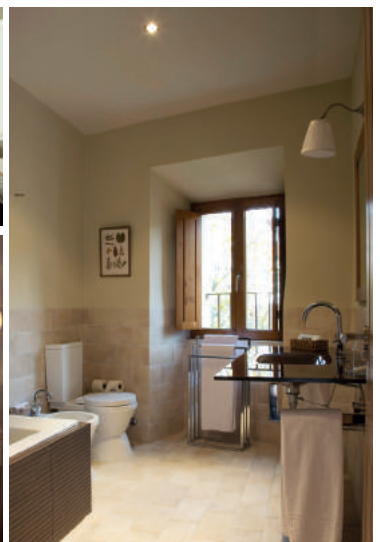
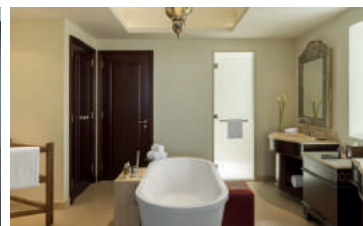
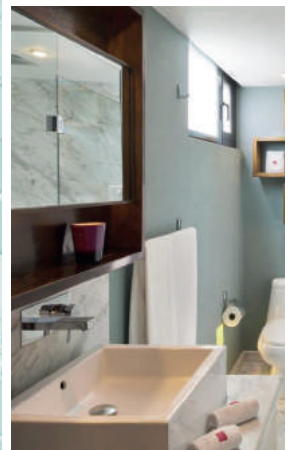

www.griferiaclever.com

Contenido web

Web content / Contenu web

+ Mapa de distribuidores



para localizar tu punto de venta más cercano.

Distributor map to locate your nearest point of sale.

Carte de distributeurs pour localiser votre point de vente le plus proche.

+ Diseño web



más intuitiva, más contenido (videos, fotos, fichas técnicas, etc) y orientada también a usuario final.

Web design more intuitive, more contents (videos, photos, technical sheets, etc.) and also aimed at the end user.

Design web plus intuitif, plus de contenu (vidéos, photos, fiches techniques, etc.) et également destiné à l'utilisateur final.

+ Blog Clever



con inspiración, ideas y consejos para tu baño y cocina.

Clever blog with inspiration, ideas and tips for your bathroom and kitchen.

Blog Clever avec inspiration, idées et astuces pour votre salle de bain et votre cuisine.

+ Síguenos en las redes sociales



@clevergriferia



Griferiaclever



Griferiaclever



Griferiaclever

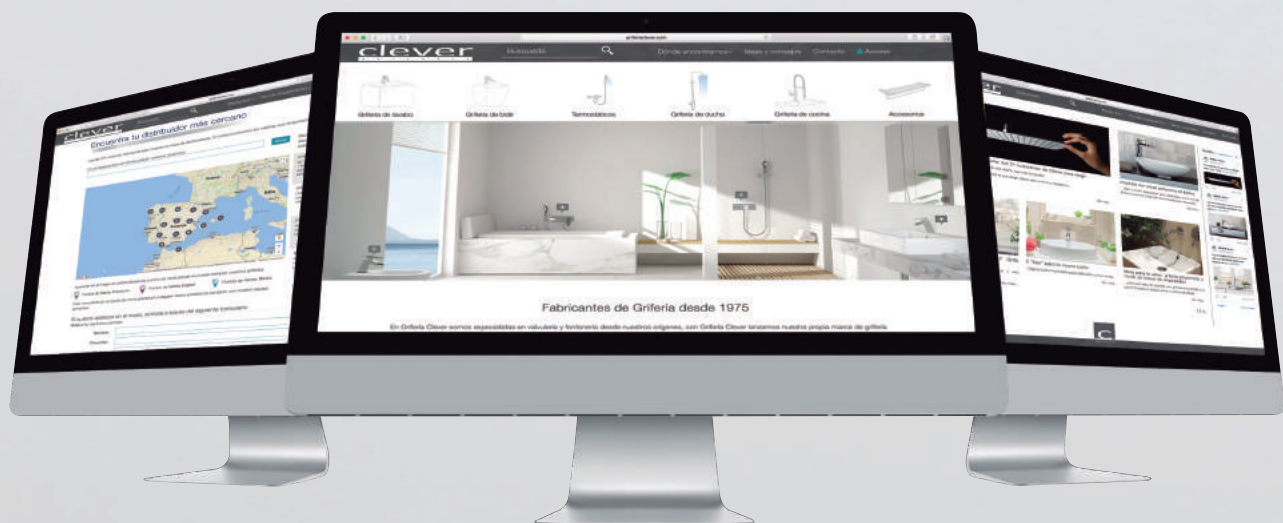

www.griferiaclever.com

www.clevertaps.com · www.robinetterieclever.com

Realidad Aumentada
Baño y Cocina

Augmented reality
Bath & Kitchen
Réalité Augmentée
Bain et Cuisine

Mejorada **usabilidad**

User friendly
Plus grande facilité
d'utilisation

Videos
integrados

Integrated videos
Videos incorporés

Dónde encontrar
nuestro producto
**Nuevo mapa de
Distribuidores**

Where to find our product.
New distributors map.

Où trouver nos produits.
Nouvelle carte des distributeurs.

Catálogo
de productos

Product catalogue
Catalogue des produits

ESCANEA TU ESPACIO DIRECTAMENTE **con tu tablet o smartphone**
E INTEGRA LAS GRIFERÍAS QUE MEJOR SE ADAPTEN **A TU DISEÑO**

DESCUBRE
CÓMO FUNCIONA
la APP CLEVER
en nuestro canal  **YouTube**

*Scan your space with your tablet or smartphone and add the
taps that suits better to your design*
*Scannez votre espace directement avec votre tablette ou
votre smartphone et sélectionnez la robinetterie qui s'adapte le
mieux à votre style*



Download Clever App Free



Discover the clever app in our Youtube channel / Découvrez le fonctionnement de la app clever sur notre canal Youtube

¿Qué significa cada icono?

What's the meaning of each icon? / Que signifie chaque symbole?

Diseño y calidad

Design & Quality | Design et qualité



PATENTED

Diseño exclusivo y patentado
Exclusive and patent design
Design exclusif et breveté



TOP WARRANTY

Garantía calidad 5 años
5 years warranty
Garantie qualité 5 ans

Seguridad

Security | Sécurité



MEDICAL

Máxima higiene
Maximum hygiene
Hygiène maximale



SAFETY BLOCK

Doble tope de seguridad para termostáticos
Double security system for thermostatic
Double système de sécurité pour thermostatique



TERMOLIMIT

Limitación temperatura
Temperature limit
Limitation de la température



THERMOSTATIC

Regulación termostática, alta precisión
Thermostatic control, high precision
Contrôle thermostatique, haute précision

NEW



ANTIVANDÁLICO

Bloqueo suministro agua a los 55 segundos
Blocking the water supply at 55 seconds
Blocage de l'approvisionnement en eau à 55 secondes

Materiales

Materials | Matériaux



EXTRA BRASS

Latón de alta calidad
High quality brass
Laiton de haute qualité



EXTRA CHROME

Alta calidad cromado
High quality chrome
Chromage haute qualité



MATT

Acabado en mate
Matt finished
Fini mat



STAINLESS STEEL

Grifería de acero inoxidable
Stainless steel taps
Robinetterie acier inox

NEW



EUROCOLGADOR

Packaging con eurocolgador
Retail packaging
Emballage avec orifice pour stockage sur broche

Medio ambiente

Environment | Environnement



AIR ADVANCED

Mezcla aire y agua
Air and water mixture
Mélange air et eau



ECONATURE

Cartucho C2/ec2 con 2 posiciones
C2/ec2 cartridge with 2 positions
Cartouche C2/ec2 avec 2 positions



PUBLIC PLACE

Diseñado para lugares públicos
Designed for public places
Conçu pour les lieux publics



PURE H₂O

Grifería para osmosis
Filter sink mixer
Robinet eau pure osmosis



WATER REDUCE

Sistema reducción de caudal
Flow reduction system
Système de réduction de débit

Tecnología

Technology | Technologie



CERAMIC CONTROL

Discos cerámicos
Ceramic disc
Disques céramiques



COLD OPEN

Apertura en frío
Cold opening
Ouverture en eau froide



COLD TOUCH

Grifería anti-quemaduras
Anti-scald
Robinetterie anti-brûlures



EASYFIX

Fácil instalación de fregaderos
Easy sink taps installation
Facilité d'installation des éviers



MAGNET

Sistema magnético de sujeción
Magnetic system of subjection
Système magnétique de fixation



































































ORIENTABLE

Aireador orientable
Easy sink taps installation
Aérateur orientable



WATERFALL

Efecto cascada
Waterfall effect
Effet cascade

PLATINUM	Ventu			Equipos para Calidad del Agua Water quality equipment Équipements pour une eau de qualité	
	Aude			Grifería para equipos de Calidad del Agua Water quality equipment taps Robinets d'équipement de qualité de l'eau	COCINA Kitchen Cuisine
	Selene			Abatible Folding spout Bec rabattable et orientable	
	Bimini			Chef	
	Marina Evo			Platinum	
	Saona Slim			Styles	
	Paula			Styles Pro	
	Nine <i>elegance</i>			Gerontológico Medical lever Manette médicale	
	Nine <i>xtreme</i>			iclever / ikansas	HIDROCLEVER
STYLES	Agora <i>elegance</i>			Rociadores Shower heads Pommes de douche	
	Agora <i>xtreme</i>			Brazos rociadores Shower arms Bras pour pomme de douche	
	Artic <i>xtreme</i>			Conjuntos de ducha Shower kits Ensembles de douche	
	Artic <i>urban</i>			Barras de ducha Sliding bars Barres de douche	
	Caiman <i>elegance</i>			Caños empotrar Bath Spouts Becs	
	Caiman <i>xtreme</i>			Jets hidromasaje Body jets Jets	
	Caiman <i>urban</i>			Soportes Wall brackets Supports	
	With2 <i>antigona</i>			Teléfonos de ducha Handsets Douchettes	
	With2 <i>morea</i>			Salidas flexo Wall outlets Sorties flexible	
STYLES PRO	Bahama <i>xtreme</i>			Flexibles Flexibles Flexibles	
	Habana <i>xtreme</i>			Gama Box	
	Start <i>elegance</i>			ACCESORIOS DE BAÑO Bathroom accessories Accessoires de salle de bain	
	Start <i>xtreme</i>			Temporizados Delay action Temporisés	COLECTIVIDADES Collective spaces Collectivités
	Start <i>urban</i>			Electrónicos NEW Electronic divises Électroniques	
	NEW Panam Evo <i>elegance</i>			Duchas higiénicas Shattafs Douches hygiéniques	
	NEW Panam Evo <i>xtreme</i>			Grifos individuales Cold water taps Robinets simples	
	NEW Panam Evo <i>urban</i>			Manetas gerontológicas Medical levers Manettes médicales	
	Panam <i>urban</i>			Termostáticos Thermostatics Thermostatiques	
	S12 <i>elegance</i>			Sistemas de ducha Shower and bath-shower systems Colonnes douche et bain-douche	
	S12 <i>xtreme</i>			Complementos y Recambios Accessories and spare parts Accessoires et pièces de rechange	
	S12 <i>urban</i>			Expositores Displays Présentoirs	
With2 <i>guayama</i>			Off Clever		
Nine <i>urban</i>			Información técnica y Certificados Technical information and certificates Information technique et certificats		
			Índice de referencias y Condiciones de Venta Item directory and Sales conditions Index des références et Conditions de vente		



99413
Lavabo
Basin Mixer
Mitiger Lavabo

PLATINUM



Ventu
22



Aude
24



Selene
26



Bimini
28



Marina Evo
34

Conceptual designs to feel your emotions

Live your bathroom



Saona Slim
36



Paula
38



Nine *elegance*
Termostática
Thermostatic / Thermostatique
42







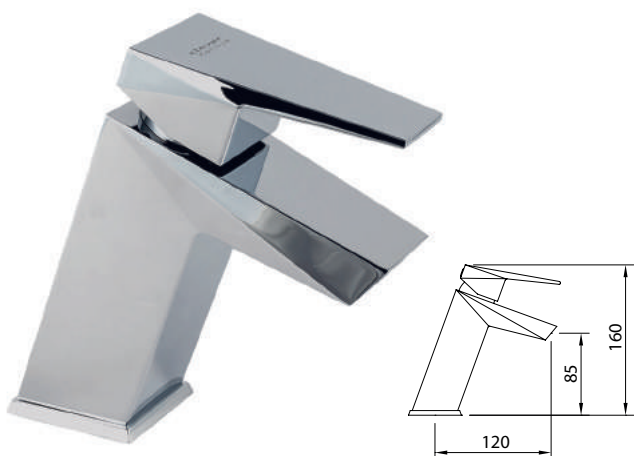

Nine **xtreme**
Termostática
Thermostatic / Thermostatique
46

Ventu Pura en esencia Pure essence | Pure essence



LAVABO 85 Basin mixer 85 | Mitigeur lavabo 85

Mezclador con aireador y flexibles M-10 3/8" x 500 mm.
Mixer, aerator, flexible hoses M-10 3/8" x 500 mm.
Mitigeur lavabo, aérateur, raccords flexibles M-10 3/8" x 500 mm

	Ref.	€	📦
 	ec1 99428	274,00	8
 	ec1 99429	282,00	8
 	ec1 99430	290,00	8





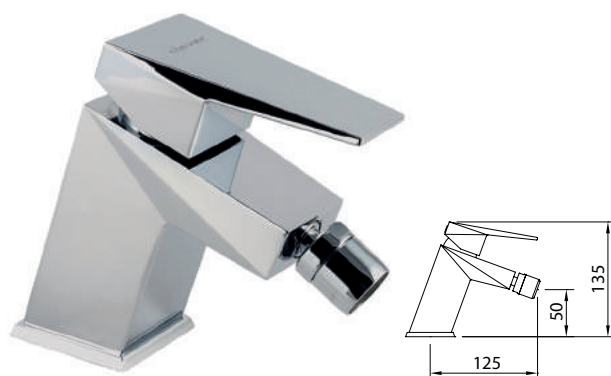



99426 99540 98492



BIDÉ Bidet mixer | Mitigeur bidet

Mezclador con aireador a rótula, flexibles M-10 3/8" x 420 mm.
Mixer, swivel aerator, flexible hoses M-10 3/8" x 420 mm.
Mitigeur bidet, aérateur, raccords flexibles M-10 3/8" x 420 mm

	Ref.	€	📦
 	ec1 99431	274,00	8
 	ec1 99432	282,00	8
 	ec1 99433	290,00	8



99426 99540 90026

Productos relacionados Related products Produits connexes



PAG. 210

iclever basin_98703 + 99718
Lavabo empotrado
Concealed basin mixer
Lavabo encastré



PAG. 297

HYDRA_98675
Válvula desagüe Universal
Universal drain quick-clac
Vidage Universel



PAG. 296

XTREME_96173
Sifón botella latón
Brass bottle trap
Siphon laiton



PAG. 296

BIMINI_97106
Válvula escuadra
Angle Valve
Robinet d'equerre

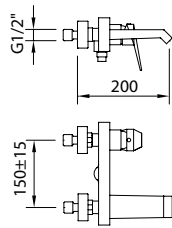

BAÑO-DUCHA
Bath-shower mixer | Mitigeur bain-douche

Mezclador con aireador baño-ducha, inversor integrado.
Bath-shower mixer with aerator, hidden diverter.
Mitigeur bain-douche, aérateur, inverseur intégré

	Ref.	€	
Incluye teléfono ducha, flexo y soporte Includes handset, hose and holder Inclus douchette, flexible et support (98884, 97670, 96413)	ec1 99434	419,00	8
Sin kit ducha Without shower kit Sans kit de douche	ACS ec1 99435	388,00	8

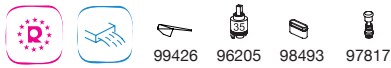

99426 96205 98493 97817

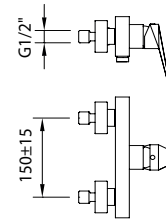
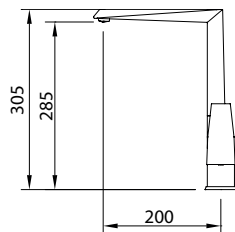

DUCHA
Shower mixer | Mitigeur douche

Mezclador para ducha.
Shower mixer.
Mitigeur douche

	Ref.	€	
Incluye teléfono ducha, flexo y soporte Includes handset, hose and holder Inclus douchette, flexible et support (98884, 97670, 96413)	ec1 99436	373,00	8
Sin kit ducha Without shower kit Sans kit de douche	ACS ec1 99437	342,00	8

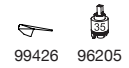

99426 96205

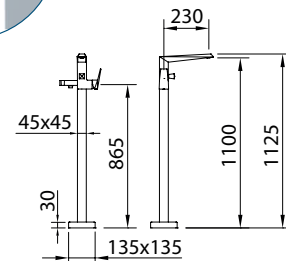

FREGADERO
Sink mixer | Mitigeur évier

Mezclador con aireador, caño fundido giratorio, flexibles M-10 3/8" x 370 mm.
Mixer with aerator, swivel cast spout, flexible hoses M-10 3/8" x 370 mm.
Mitigeur évier bec orientable, aérateur, raccords flexibles M-10 3/8" x 370 mm

	Ref.	€	
ACS ec1	99438	347,00	8
ACS ec3	99708	351,00	8



99427 96199 - ec1 99665 - ec3 97688 98774

BAÑO DUCHA FIJACIÓN SUELO
Floor standing bath-shower mixer
Mitigeur bain-douche sur colonne avec prise d'eau au sol

Baño-ducha fijación suelo con aireador e inversor automático.
Floor standing bath-shower mixer, with aerator and automatic diverter.
Mitigeur bain-douche sur colonne avec prise d'eau au sol, brise-jet, inverseur automatique



Syvari 98884 97670

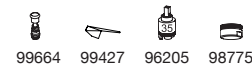

99664 99427 96205 98775

	Ref.	€	
ec1	99439	916,00	2



PAG. 250

VENTU_99470
Accesorios de baño
Bathroom accessories
Accessoires de salle de bain



PAG. 212

iclever2_98711 + 99719
Ducha empotrada 1 vía
Concealed bath-shower 1 outlet diverter
Douche encastré 1 voie



PAG. 214

iclever2_98711 + 99720
Ducha empotrada 2 vías
Concealed bath-shower 2 outlet diverter
Douche encastré 2 voie



NEW

PAG. 266

PLATINUM_60739
Grifo electrónico
Sensor tap
Lavabo électronique



PAG. 226

TREND_99626
Conjunto barra ducha
Sliding bar set
Ensemble barre de douche



Aude

Espíritu libre
Free spirit | Esprit libre



LAVABO 205
Tall basin mixer 205 | Mitigeur lavabo 205

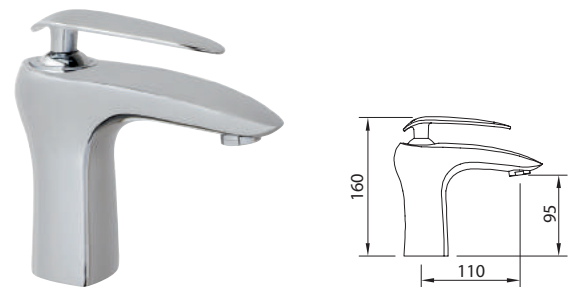

Mezclador alto con aireador y flexibles M-10 3/8" x 370 mm.
Tall mixer, aerator, flexible hoses M-10 3/8" x 370 mm.
Mitigeur Lavabo bec haut, aérateur, raccords flexibles M-10 3/8" x 370 mm

	Ref.	€	📦
	97811	295,00	6
	97842	303,00	6
	97843	311,00	6



LAVABO 95
Basin mixer 95 | Mitigeur lavabo 95

Mezclador con aireador y flexibles M-10 3/8" x 370 mm.
Mixer, aerator, flexible hoses M-10 3/8" x 370 mm.
Mitigeur Lavabo, aérateur, raccords flexibles M-10 3/8" x 370 mm

	Ref.	€	📦
	97810	243,00	8
	97840	251,00	8
	97841	259,00	8



Productos relacionados
Related products
Produits connexes



PAG. 252

elegance_99451
Accesorios de baño
Bathroom accessories
Accessoires de salle de bain



PAG. 297

VELA_97395_96255
Válvula desagüe metálico
Drain quick-clac metallic
Vidage métallique



PAG. 296

ELEGANCE_96174
Sifón botella latón
Brass bottle trap
Siphon laiton



PAG. 296

DESIGN_40010
Válvula escuadra
Angle Valve
Robinet d'equerre

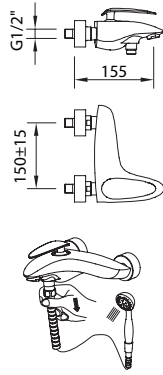

BAÑO-DUCHA
Bath-shower mixer | Mitigeur bain-douche

Mezclador con aireador baño-ducha, inversor integrado.
Bath-shower mixer with aerator, hidden diverter.
Mitigeur bain-douche, aérateur, inverseur intégré

	Ref.	€	📦
Incluye teléfono ducha, flexo y soporte Includes handset, hose and holder Inclus douchette, flexible et support (97142, 97670, 96942)	97813	394,00	6
Sin kit ducha Without shower kit Sans kit de douche	97846	363,00	6

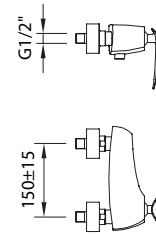

DUCHA
Shower mixer | Mitigeur douche

Mezclador para ducha.
Shower mixer.
Mitigeur douche

	Ref.	€	📦
Incluye teléfono ducha, flexo y soporte Includes handset, hose and holder Inclus douchette, flexible et support (97142, 97670, 96942)	97814	348,00	6
Sin kit ducha Without shower kit Sans kit de douche	97847	317,00	6

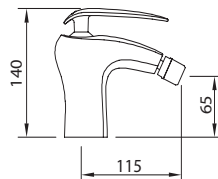

BIDÉ
Bidet mixer | Mitigeur bidet

Mezclador con aireador a rótula, flexibles M-10 3/8" x 370 mm.
Mixer, swivel aerator, flexible hoses M-10 3/8" x 370 mm.
Mitigeur bidet, aérateur rotule, raccords flexibles M-10 3/8" x 370 mm

	Ref.	€	📦
97812	243,00	6	
97844	251,00	6	
97845	259,00	6	

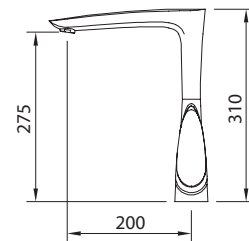

FREGADERO
Sink mixer | Mitigeur évier

Mezclador con aireador, caño fundido giratorio, flexibles M-10 3/8" x 370 mm.
Mixer with aerator, swivel cast spout, flexible hoses M-10 3/8" x 370 mm.
Mitigeur évier bec orientable, aérateur, raccords flexibles M-10 3/8" x 370 mm.

	Ref.	€	📦
97815	295,00	8	



Tecnología
Technology / Technologie

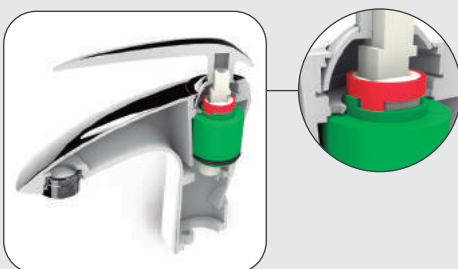

SISTEMA TERMOLIMIT DE LIMITACIÓN DE TEMPERATURA

TermoLimit system, limits the temperature. Save energy and protect the children to be scalded.

Système Termolimit de limitation de température. Economisez l'énergie et protégez les plus petits des brûlures.

El anillo situado en el cartucho nos permite limitar la apertura lateral de la palanca del grifo.
The ring located in the cartridge allows us to limit the opening of the faucet lever.
Une bague est placée sur la partie supérieure de la cartouche pour limiter l'ouverture latérale de la manette.

Selene Inspiración y diseño

Inspiration and design | Inspiration et design

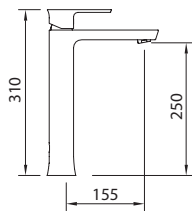

LAVABO 250
Tall basin mixer 250 | Mitigeur lavabo 250

Mezclador alto con aireador y flexibles M-10 3/8" x 370 mm.
Tall mixer, aerator, flexible hoses M-10 3/8" x 370 mm.
Mitigeur Lavabo bec haut, aérateur, raccords flexibles M-10 3/8" x 370 mm.

	Ref.	€	📦
	ec1 98009	295,00	8



95168 98238 90025

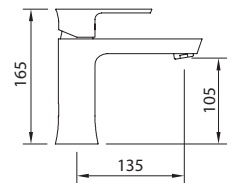

LAVABO 105
Basin mixer 105 | Mitigeur lavabo 105

Mezclador con aireador y flexibles M-10 3/8" x 370 mm.
Mixer, aerator, flexible hoses M-10 3/8" x 370 mm.
Mitigeur Lavabo, aérateur, raccords flexibles M-10 3/8" x 370 mm.

	Ref.	€	📦
	ec1 98010	243,00	8
	ec1 98017	251,00	8
	ec1 98018	259,00	8



95168 98238 90025

Productos relacionados
Related products
Produits connexes



PAG. 250

VENTU_99470
Accesorios de baño
Bathroom accessories
Accessoires de salle de bain



PAG. 297

HYDRA_98675
Válvula deságüe Universal
Universal drain quick-clac
Vidage Universel



PAG. 296

XTREME_96173
Sifón botella latón
Brass bottle trap
Siphon laiton



PAG. 297

DESIGN_40010
Válvula escuadra
Angle Valve
Robinet d'equerre

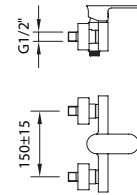
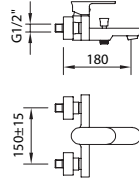

BAÑO-DUCHA
Bath-shower mixer | Mitigeur bain-douche

Mezclador con aireador baño-ducha, inversor automático.
Bath-shower mixer with aerator, automatic diverter.
Mitigeur bain-douche, aérateur, inverseur automatique

	Ref.	€	
Incluye teléfono ducha, flexo y soporte Includes handset, hose and holder Inclus douchette, flexible et support (96786, 97670, 96413)	ec1 98012	394,00	8
Sin kit ducha Without shower kit Sans kit de douche	ACS ec1 98150	363,00	8

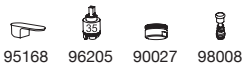

DUCHA
Shower mixer | Mitigeur douche

Mezclador para ducha.
Shower mixer.
Mitigeur douche

	Ref.	€	
Incluye teléfono ducha, flexo y soporte Includes handset, hose and holder Inclus douchette, flexible et support (96786, 97670, 96413)	ec1 98013	348,00	8
Sin kit ducha Without shower kit Sans kit de douche	ACS ec1 98151	317,00	8

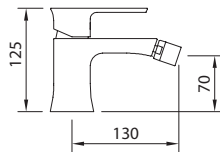

BIDÉ
Bidet mixer | Mitigeur bidet

Mezclador con aireador a rótula, flexibles M-10 3/8" x 370 mm.
Mixer, swivel aerator, flexible hoses M-10 3/8" x 370 mm.
Mitigeur bidet, aérateur rotule, raccords flexibles M-10 3/8" x 370 mm

	Ref.	€	
ACS	ec1 98011	243,00	6
ACS	ec1 98019	251,00	6
ACS	ec1 98020	259,00	6

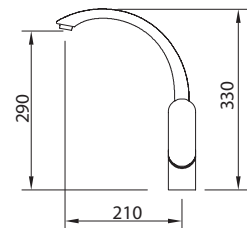

FREGADERO
Sink mixer | Mitigeur évier

Mezclador con aireador, caño fundido giratorio, flexibles M-10 3/8" x 370 mm.
Mixer with aerator, swivel cast spout, flexible hoses M-10 3/8" x 370 mm.
Mitigeur évier bec orientable, aérateur, raccords flexibles M-10 3/8" x 370 mm

	Ref.	€	
ACS	ec1 98014	270,00	8



MIRROR EFFECT

*Pulido espejo
Mirror Effect
Polissage miroir*

El pulido de la gama Selene se realiza mediante tecnología CNC, obteniendo una planicidad de efecto espejo.
The surface polished for Selene range is produced using the CNC technology, getting perfect flat sides with mirror effect.
L'application de la technologie CNC au dégrossissage et polissage de la gamme Selene permet l'obtention d'une surface plane à effet miroir.

Bimini

Transición natural
Natural transition | Transition Naturelle

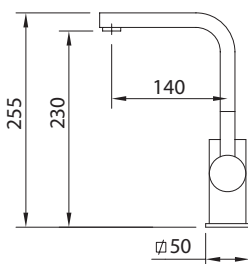

LAVABO 230

Tall basin mixer 230 | Mitigeur lavabo 230

Mezclador alto, caño giratorio, aireador, flexibles M-10 3/8" x 370 mm.
Tall mixer, aerator, swivel spout, flexible hoses M-10 3/8" x 370 mm.
Mitigeur lavabo haut, bec orientable, aérateur, raccords flexibles M-10 3/8" x 370 mm

	Ref.	€	📦
	97042	243,00	8
	97852	251,00	8
	97132	259,00	8

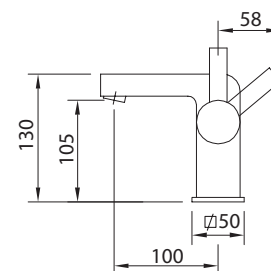
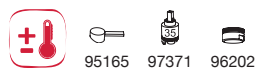

LAVABO 105

Basin mixer 105 | Mitigeur lavabo 105

Mezclador con aireador y flexibles M-10 3/8" x 370 mm.
Mixer, aerator, flexible hoses M-10 3/8" x 370 mm.
Mitigeur Lavabo, aérateur, raccords flexibles M-10 3/8" x 370 mm

	Ref.	€	📦
	97041	243,00	8
	97850	251,00	8
	97131	259,00	8

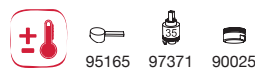

Productos relacionados
Related products
Produits connexes



PAG. 254

XTREME_98655
Accesorios de baño
Bathroom accessories
Accessoires de salle de bain



PAG. 297

HYDRA_98675
Válvula desagüe Universal
Universal drain quick-clac
Vidage Universel



PAG. 296

XTREME_96173
Sifón botella latón
Brass bottle trap
Siphon laiton



PAG. 296

BIMINI_97106
Válvula escuadra
Angle Valve
Robinet d'equerre

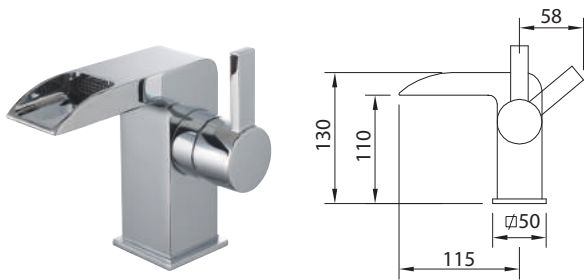

LAVABO 110
Basin mixer 110 | Mitigeur lavabo 110

Mezclador, rompeaguas y flexibles M-10 3/8" x 370 mm.
Mixer, open spout, flexible hoses M-10 3/8" x 370 mm.
Mitigeur lavabo, brise-jet, raccords flexibles M-10 3/8" x 370 mm

	Ref.	€	Q
	98446	269,00	8
	98498	277,00	8
	98499	285,00	8



LAVABO REPISA 105
3 hole deck basin 105 | Mélangeur lavabo 105 3 trous

Mezclador repisa, caño con aireador.
Three hole deck basin, spout with aerator.
Mélangeur lavabo 3 trous, aérateur

	Ref.	€	Q
	97053	290,00	8
	97855	298,00	8
	97134	306,00	8

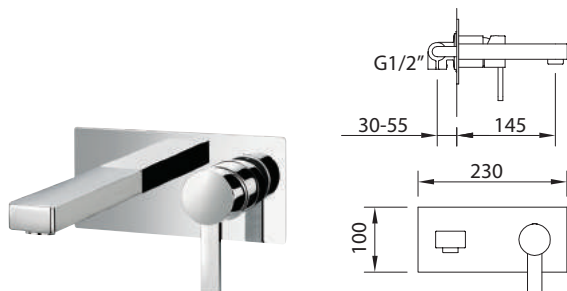

LAVABO EMPOTRAR
Concealed basin | Mitigeur lavabo à encastrer

Mezclador empotrable, caño mural con aireador, longitud 145 mm.
Concealed basin, aerator, wall spout length 145 mm.
Mitigeur lavabo encastré, aérateur, bec 145 mm.

	Ref.	€	Q
	97059	259,00	8

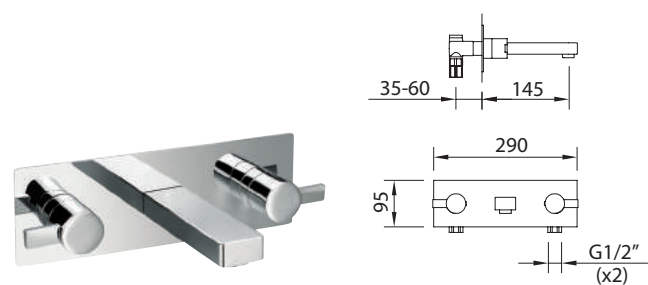

LAVABO EMPOTRAR
Concealed basin | Mélangeur lavabo à encastrer

Mezclador empotrable, caño mural con aireador, longitud 145 mm.
Concealed basin, aerator, wall spout length 145 mm.
Mélangeur lavabo encastré, aérateur, bec 145 mm.

	Ref.	€	Q
	97054	259,00	4

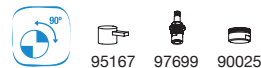

Tecnología
Technology / Technologie



SISTEMA ECONATURE.
AHORRO DE AGUA.
DOS POSICIONES DE APERTURA DE LA MANETA.

Econature system.
Save water. Two positions of opening the handle.

Système Econature.
Économie d'eau. Deux positions d'ouverture de la poignée.

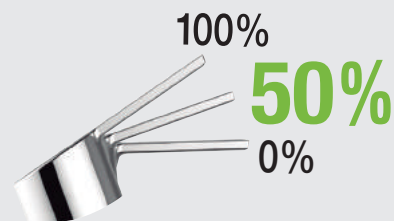

Bimini

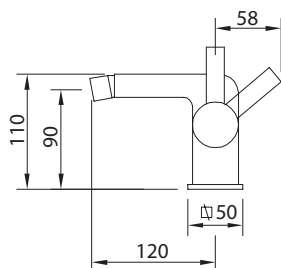

BIDÉ

Bidet mixer | Mitigeur bidet

Mezclador con aireador a rótula y flexibles M-10 3/8" x 370 mm.
Mixer, swivel aerator, flexible hoses M-10 3/8" x 370 mm.
Mitigeur bidet, aérateur rotule, raccords flexibles M-10 3/8" x 370 mm

	Ref.	€	📦
	97043	243,00	8
	97851	251,00	8
	97133	259,00	8

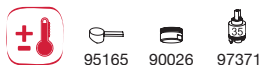

95165 90026 97371

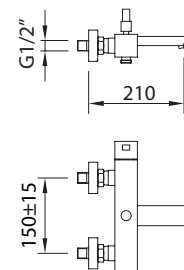

BAÑO-DUCHA

Bath-Shower mixer | Mitigeur bain-douche

Mezclador con aireador baño-ducha, inversor automático.
Bath-shower mixer with aerator, automatic diverter.
Mitigeur bain-douche, aérateur, inverseur automatique

	Ref.	€	📦
	97044	394,00	4

Sin kit ducha
Without shower kit
Sans kit de douche

	97853	363,00	4
--	-------	--------	---



95165 90027 97371 97474

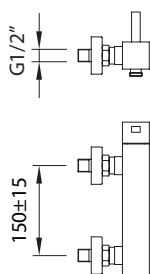

DUCHA

Shower mixer | Mitigeur douche

Mezclador para ducha.
Shower mixer.
Mitigeur douche

	Ref.	€	📦
	97045	348,00	6

Sin kit ducha
Without shower kit
Sans kit de douche

	97854	317,00	8
--	-------	--------	---

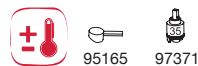

95165 97371

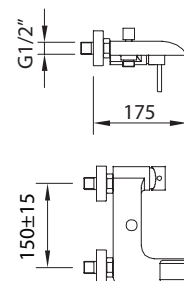

BAÑO-DUCHA

Bath-shower mixer | Mitigeur bain-douche

Mezclador con rompeaguas, inversor automático para baño-ducha.
Bath-shower, open spout mixer with automatic diverter.
Mitigeur bain-douche, brise-jet, inverseur automatique

	Ref.	€	📦
	98447	420,00	6

Sin kit ducha
Without shower kit
Sans kit de douche

	98785	389,00	6
--	-------	--------	---



97371 97474

Productos relacionados

Related products
Produits connexes



PAG. 254

XTREME_ 98655
Accesorios de baño
Bathroom accessories
Accessoires de salle de bain



PAG. 235

PASCUA_ 97112
Soporte articulado
Articulated holder
Support douchette orientable



PAG. 212

iclever 2_ 98711 + 98714
Ducha empotrada 1 vía
Concealed bath-shower 1 outlet diverter
Douche encastré 1 voie



PAG. 214

iclever 2_ 98711 + 98729
Ducha empotrada 2 vías
Concealed bath-shower 2 outlet diverter
Douche encastré 2 voies



DUCHA TERMOSTÁTICA
Thermostatic Shower mixer | Douche thermostatique

Mezclador **termostático** para ducha.
 Thermostatic shower mixer.
 Mitigreur douche thermostatique

Incluye teléfono ducha, flexo y soporte
 Includes handset, hose and holder
 Inclus douchette, flexible et support
 (96412, 97114, 97112)

Ref.	€	📦
96490	345,00	6

Sin kit ducha
 Without shower kit
 Sans kit de douche

Ref.	€	📦
98153	314,00	6



BAÑO-DUCHA REPISA | Four hole deck bath-shower
Mélangeur bain-douche 4 trous

Mezclador repisa, caño con aireador.
 Four hole deck bath-shower mixer with aerator.
 Mélangeur bain-douche 4 trous, aérateur

Incluye
 Includes
 Inclus

Ref.	€	📦
97060	430,00	4

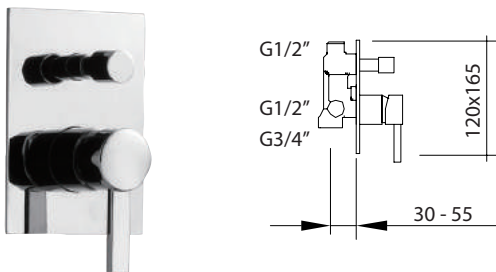
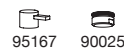

BAÑO-DUCHA EMPOTRAR - 2 VÍAS
Wall mounted bath-shower mixer-2 outlet diverter
Mitigreur à encastrer 2 voies

Mezclador empotrable 1/2" para baño-ducha, inversor automático.
 Concealed bath-shower kit 1/2", automatic diverter.
 Mitigreur encastré, 1/2", inverseur automatique

Ref.	€	📦
ec2 97997	226,00	10

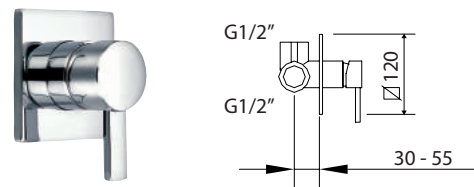
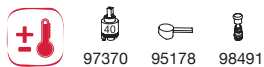

BAÑO-DUCHA EMPOTRAR - 1 VÍA
Wall mounted shower mixer-1 outlet diverter
Mitigreur à encastrer 1 voie

Mezclador empotrable 1/2" para ducha.
 Concealed shower kit 1/2".
 Mitigreur encastré, 1/2"

Ref.	€	📦
ec2 97998	166,00	8

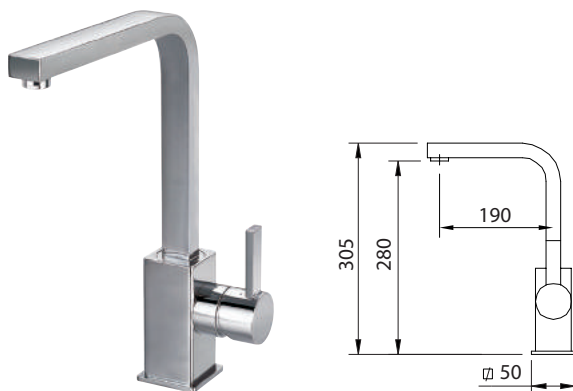

FREGADERO
Sink mixer | Mitigreur évier

Mezclador con aireador, caño conformado giratorio, flexibles M-10 3/8" x 370 mm.
 Mixer with aerator, swivel tube spout, flexible hoses M-10 3/8" x 370 mm.
 Mitigreur évier bec orientable, aérateur, raccords flexibles M-10 3/8" x 370 mm

Ref.	€	📦
ec2 97046	233,00	8

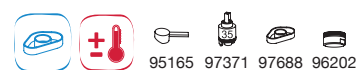

Bimini

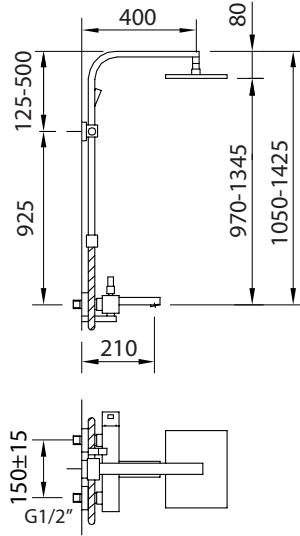

CONJUNTO BAÑO-DUCHA EXTENSIBLE Extensible bath-shower system Colonne mitigeur bain-douche extensible

Mezclador de baño-ducha con tubo extensible.
Extensible bath-shower system.
Support douchette orientable, inverseur automatique, pomme de douche, douchette et flexible.

Incluye
Includes
Inclus



	Ref.	€	
ec2	97055	985,00	3

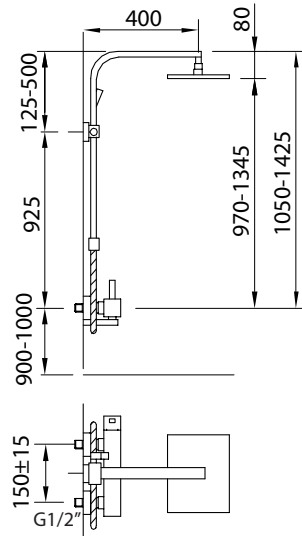

CONJUNTO DE DUCHA EXTENSIBLE Extensible shower system Colonne mitigeur douche extensible

Mezclador de ducha con tubo extensible.
Extensible shower system.
Support douchette orientable, inverseur automatique, pomme de douche, douchette et flexible.

Incluye
Includes
Inclus



	Ref.	€	
ec2	97056	936,00	3

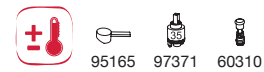

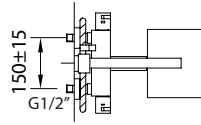
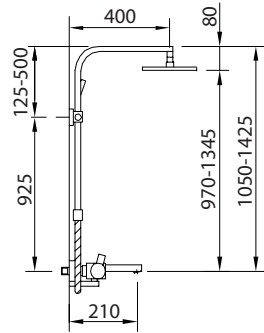

Inversor incorporado en la maneta de caudal
 Integral diverter in the flow handle
 Inverseur intégré dans la poignée

CONJUNTO DE BAÑO-DUCHA TERMOSTÁTICO EXTENSIBLE
Extensible Thermostatic bath-shower system
Colonne thermostatique bain-douche extensible

Mezclador de baño-ducha **termostático** con tubo extensible.
 Adjustable thermostatic bath-shower system.
 Support douchette orientable, inversor automático/cerámico, pomme de douche, douchette et flexible

Incluye
 Includes
 Inclus



Ref.	€	3
97057	1.182,00	3

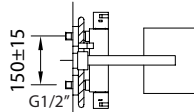
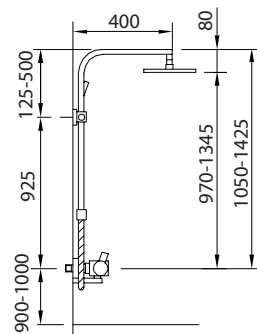

CONJUNTO DE DUCHA TERMOSTÁTICO EXTENSIBLE
Extensible Thermostatic shower system
Colonne thermostatique douche extensible

Mezclador de ducha **termostático** con tubo extensible.
 Adjustable thermostatic shower system.
 Support douchette orientable, inversor automático, pomme de douche, douchette et flexible

Incluye
 Includes
 Inclus



Ref.	€	3
97058	1.017,00	3





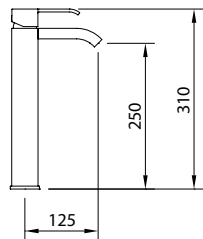

Marina Evo Fusión de formas

Forms fusion | Fusion des formes



LAVABO 250
Tall basin mixer 250 | Mitigreur lavabo 250



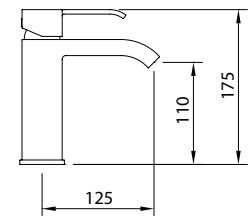

Mezclador alto con aireador y flexibles M-10 3/8" x 370 mm.
Tall mixer, aerator, flexible hoses M-10 3/8" x 370 mm.
Mitigreur Lavabo bec haut, aérateur, raccords flexibles M-10 3/8" x 370 mm

	Ref.	€	📦
	ec1 99410	267,00	6
 	ec1 99411	275,00	6
 	ec1 99412	283,00	6



LAVABO 110
Basin mixer 110 | Mitigreur lavabo 110

Mezclador con aireador y flexibles M-10 3/8" x 500 mm.
Mixer, aerator, flexible hoses M-10 3/8" x 500 mm.
Mitigreur lavabo, aérateur, raccords flexibles M-10 3/8" x 500 mm

	Ref.	€	📦
	ec1 99413	202,00	8
 	ec1 99414	210,00	8
 	ec1 99415	218,00	8



Productos relacionados
Related products
Produits connexes



PAG. 254

XTREME_98655
Accesorios de baño
Bathroom accessories
Accessoires de salle de bain



PAG. 297

HYDRA_98675
Válvula desague Universal
Universal drain quick-clac
Vidage Universel



PAG. 296

XTREME_96173
Sifón botella latón
Brass bottle trap
Siphon laiton



PAG. 296

BIMINI_97106
Válvula escuadra
Angle Valve
Robinet d'equerre

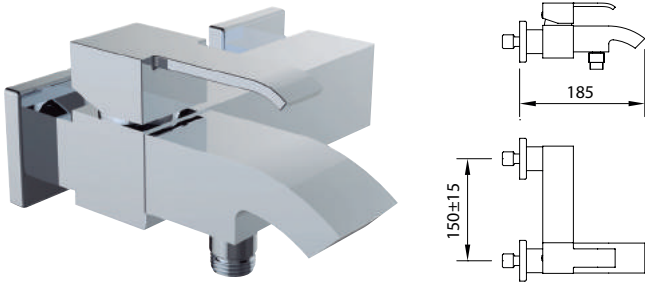

BAÑO-DUCHA
Bath-shower mixer | Mitigeur bain-douche

Mezclador con aireador baño-ducha, inversor integrado.
Bath-shower mixer with aerator, hidden diverter.
Mitigeur bain-douche, aérateur, inverseur intégré

	Ref.	€	
Incluye teléfono ducha, flexo y soporte Includes handset, hose and holder Inclus douchette, flexible et support (98884, 97670, 96413)	ec1 99419	347,00	8
Sin kit ducha Without shower kit Sans kit de douche	ACS ec1 99420	316,00	8

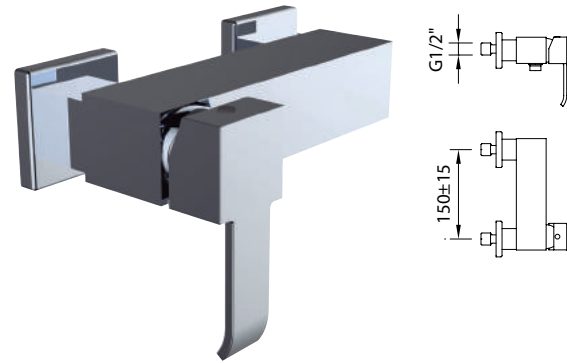

DUCHA
Shower mixer | Mitigeur douche

Mezclador para ducha.
Shower mixer.
Mitigeur douche

	Ref.	€	
Incluye teléfono ducha, flexo y soporte Includes handset, hose and holder Inclus douchette, flexible et support (98884, 97670, 96413)	ec1 99421	257,00	8
Sin kit ducha Without shower kit Sans kit de douche	ACS ec1 99422	226,00	8

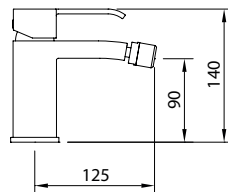
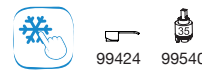

BIDÉ
Bidet mixer | Mitigeur bidet

Mezclador con aireador a rótula, flexibles M-10 3/8" x 420 mm.
Mixer, swivel aerator, flexible hoses M-10 3/8" x 420 mm.
Mitigeur bidet, aérateur rotule, raccords flexibles M-10 3/8" x 420 mm

	Ref.	€	
ACS	ec1 99416	202,00	8
SYNTHETIC ACS	ec1 99417	210,00	8
METALLIC ACS	ec1 99418	218,00	8

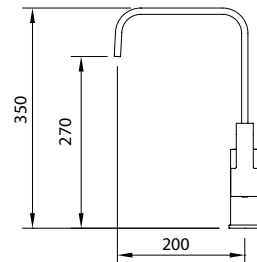

FREGADERO
Sink mixer | Mitigeur évier

Mezclador con aireador, caño conformado giratorio, flexibles M-10 3/8" x 420 mm.
Mixer with aerator, swivel tube spout, flexible hoses M-10 3/8" x 420 mm.
Mitigeur évier bec orientable, aérateur, raccords flexibles M-10 3/8" x 420 mm

	Ref.	€	
ACS	ec1 99423	210,00	8
ACS ec3	99715	214,00	8



Tecnología
Technology / Technologie



EASYFIX
Fácil instalación de fregaderos
Easy sink taps installation
Facilité d'installation des éviers

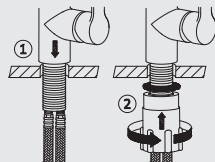

Dispositivo que permite el montaje con la mano, sin la necesidad de emplear herramientas.

Device that allows the assembly by hand, without any tools.

Dispositif permettant un montage sans besoin d'outil spécifique.

Saona Slim

Lineas puras
Pure lines | Lignes pures



LAVABO 250
Tall basin mixer 250 | Mitigeur lavabo 250

Mezclador con aireador y flexibles M-10 3/8" x 370 mm.
Mixer, aerator, flexible hoses M-10 3/8" x 370 mm.
Mitigeur Lavabo, aérateur, raccords flexibles M-10 3/8" x 370 mm

	Ref.	€	
	ec1 60118	199,00	8



95244 60199 98774

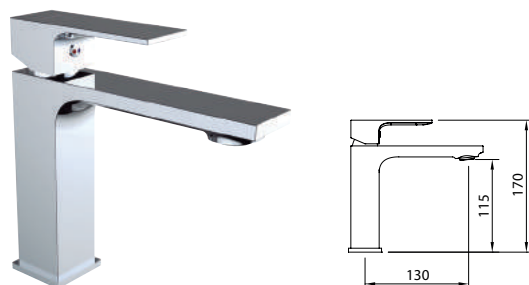

LAVABO 115
Basin mixer 115 | Mitigeur lavabo 115

Mezclador con aireador y flexibles M-10 3/8" x 500 mm.
Mixer, aerator, flexible hoses M-10 3/8" x 500 mm.
Mitigeur Lavabo, aérateur, raccords flexibles M-10 3/8" x 500 mm

	Ref.	€	
	ec1 60115	147,00	8
	ec1 60116	155,00	8
	ec1 60117	163,00	8

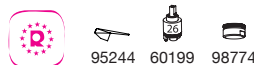

95244 60199 98774

Productos relacionados
Related products
Produits connexes



PAG. 254

XTREME_98655
Accesorios de baño
Bathroom accessories
Accessoires de salle de bain



PAG. 297

HYDRA_98675
Válvula desague Universal
Universal drain quick-clac
Vidage Universel



PAG. 296

XTREME_96173
Sifón botella latón
Brass bottle trap
Siphon laiton



PAG. 296

BIMINI_97106
Válvula escuadra
Angle Valve
Robinet d'equerre



BAÑO-DUCHA
Bath-shower mixer | Mitigeur bain-douche

Mezclador baño-ducha, aireador, inversor automático.
Bath-shower mixer, aerator, automatic diverter.
Mitigeur bain-douche, aérateur, inverseur automatique

	Ref.	€	8
Incluye teléfono ducha, flexo y soporte Includes handset, hose and holder Inclus douchette, flexible et support (98884, 97670, 96413)	ec1 60124	238,00	8
Sin kit ducha Without shower kit Sans kit de douche	ACS ec1 60125	207,00	8



DUCHA
Shower mixer | Mitigeur douche

Mezclador para ducha.
Shower mixer.
Mitigeur douche

	Ref.	€	8
Incluye teléfono ducha, flexo y soporte Includes handset, hose and holder Inclus douchette, flexible et support (98884, 97670, 96413)	ec1 60126	202,00	8
Sin kit ducha Without shower kit Sans kit de douche	ACS ec1 60127	171,00	8

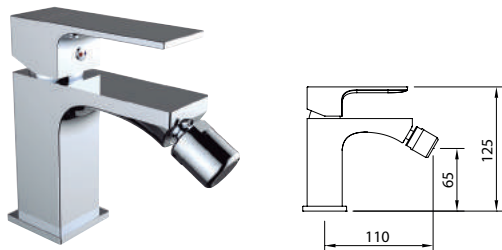

BIDÉ
Bidet mixer | Mitigeur bidet

Mezclador con aireador a rótula, flexibles M-10 3/8" x 420 mm.
Mixer, swivel aerator, flexible hoses M-10 3/8" x 420 mm.
Mitigeur bidet, aérateur rotule, raccords flexibles M-10 3/8" x 420 mm

	Ref.	€	8
ACS	ec1 60121	147,00	8
ACS SYNTHETIC	ec1 60122	155,00	8
ACS METALLIC	ec1 60123	163,00	8

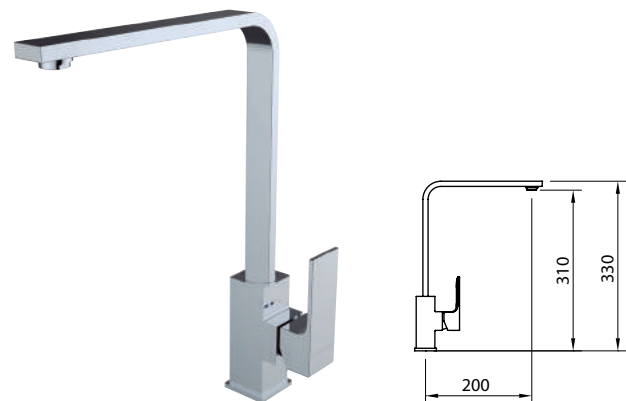

FREGADERO
Sink mixer | Mitigeur évier

Mezclador con aireador, caño tubo giratorio, flexibles M-10 3/8" x 370 mm.
Mixer with aerator, swivel spout, flexible hoses M-10 3/8" x 370 mm.
Mitigeur évier bec orientable, aérateur, raccords flexibles M-10 3/8" x 370 mm.

	Ref.	€	8
ACS	ec1 60128	177,00	8

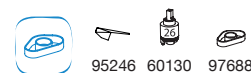

Tecnología
Technology / Technologie

AIREADOR ORIENTABLE para un mayor confort durante su uso

Orientable aerator for greater comfort during its use | Aérateur orientable pour plus de confort lors de l'utilisation



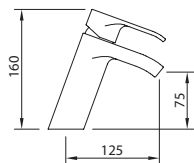

Paula Estilo propio Own style | Style unique



LAVABO 75 Basin mixer 75 | Mitigeur lavabo 75

Mezclador con aireador y flexibles M-10 3/8" x 370 mm.
Mixer, aerator, flexible hoses M-10 3/8" x 370 mm.
Mitigeur Lavabo, aérateur, raccords flexibles M-10 3/8" x 370 mm

	Ref.	€	📦
	ec1 98197	147,00	8
	ec1 98202	155,00	8
	ec1 98203	163,00	8

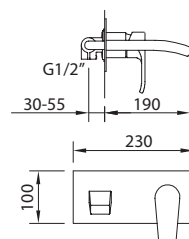
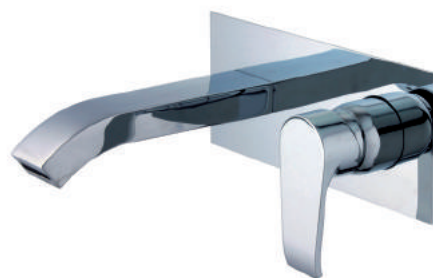

LAVABO A EMPOTRAR Concealed basin mixer | Lavabo à encastrer

Mezclador empotrable, caño mural con aireador, longitud 190 mm.
Concealed basin, aerator, wall spout length 190 mm.
Mélangeur lavabo encastré, aérateur, bec 190 mm.

	Ref.	€	📦
	ec1 98413	217,00	6

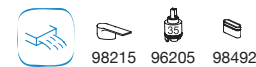

Productos relacionados Related products Produits connexes



PAG-252

elegance_99451
Accesorios de baño
Bathroom accessories
Accessoires de salle de bain



PAG-297

VELA_97395_96255
Válvula desagüe metálico
Drain quick-clac metallic
Vidage métallique



PAG-296

ELEGANCE_96174
Sifón botella latón
Brass bottle trap
Siphon laiton



PAG-296

DESIGN_40010
Válvula escuadra
Angle Valve
Robinet d'equerre



BAÑO-DUCHA
Bath-shower mixer | Mitigeur bain-douche

Mezclador baño-ducha, aireador, inversor automático.
Bath-shower mixer, aerator, automatic diverter.
Mitigeur bain-douche, aérateur, inverseur automatique

	Ref.	€	
Incluye teléfono ducha, flexo y soporte Includes handset, hose and holder Inclus douchette, flexible et support (96786, 97670, 96413)	ec1 98199	220,00	6
Sin kit ducha Without shower kit Sans kit de douche	ACS ec1 98539	189,00	6



DUCHA
Shower mixer | Mitigeur douche

Mezclador para ducha.
Shower mixer.
Mitigeur douche

	Ref.	€	
Incluye teléfono ducha, flexo y soporte Includes handset, hose and holder Inclus douchette, flexible et support (96786, 97670, 96413)	ec1 98200	174,00	6
Sin kit ducha Without shower kit Sans kit de douche	ACS ec1 98540	143,00	6

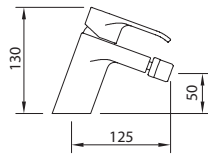

BIDÉ
Bidet mixer | Mitigeur bidet

Mezclador con aireador a rótula, flexibles M-10 3/8" x 370 mm.
Mixer, swivel aerator, flexible hoses M-10 3/8" x 370 mm.
Mitigeur bidet, aérateur rotule, raccords flexibles M-10 3/8" x 370 mm

	Ref.	€	
ACS ec1 98198	147,00	8	
SYNTHETIC ACS ec1 98204	155,00	8	
METALLIC ACS ec1 98205	163,00	8	

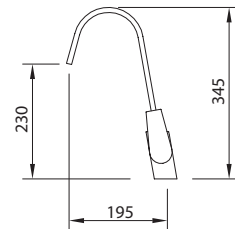

FREGADERO
Sink mixer | Mitigeur évier douchette

Mezclador con rompeaguas, caño conformado giratorio, flexibles M-10 3/8" x 370 mm.
Mixer with water breaker, swivel tube spout, flexible hoses M-10 3/8" x 370 mm.
Mitigeur évier bec orientable, brise-jet, raccords flexibles M-10 3/8" x 370 mm

	Ref.	€	
ACS ec1 98201	177,00	8	



DESMONTAJE AIREADOR ENRASADO | Aerator dismantling | Démontage aérateur caché

Tecnología
Technology / Technologie



Paula

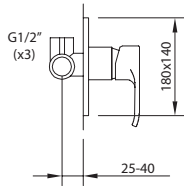

DUCHA EMPOTRAR / 1 VÍA | Wall mounted shower mixer / 1 outlet diverter | Mitigeur à encastrer / 1 voie

Mezclador empotrable de 1/2" para ducha.
Concealed shower set 1/2".
Mitigeur encastré, 1/2"

Ref.	€	
ec1 98417	109,00	12

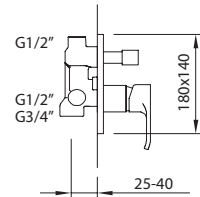

BAÑO-DUCHA EMPOTRAR / 2 VÍAS | Wall mounted bath-shower mixer / 2 outlet diverter | Mitigeur à encastrer / 2 voies

Mezclador empotrable de 1/2" para baño-ducha, inversor automático.
Concealed bath-shower set 1/2", automatic diverter.
Mitigeur encastré, 1/2", inverseur automatique

Ref.	€	
ec1 98416	149,00	12

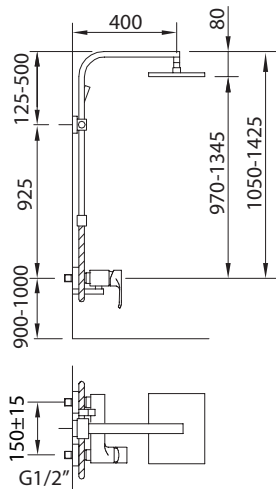

CONJUNTO DE DUCHA EXTENSIBLE | Shower system | Colonne mitigeur douche extensible

Mezclador de ducha con tubo extensible.
Adjustable shower system.
Support douchette orientable, inverseur automatique, pomme de douche, douchette et flexible

Incluye
Includes
Inclus

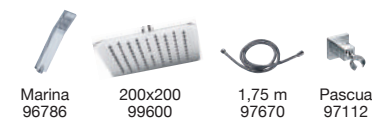

Ref.	€	
ec1 98415	725,00	4



Productos relacionados Related products Produits connexes



PAG. 222

SLIM INOX AIR_99601
Rociador 400x250mm
Shower head
Pomme de douche



PAG. 225

LUZIA_96153
Brazo rociador
Shower arm
Bras de douche



PAG. 234

STYLE AIR_99612
Teléfono de ducha
Handset
Douchette



PAG. 228

TREND_60690
Barra de ducha empotrada
Concealed sliding bar
Barre de douche encastré



98197 | Lavabo
Basin Mixer
Mitiger Lavabo

98415
Conjunto de ducha extensible
Shower system
Colonne mitigeur douche extensible



Nine *elegance*



TERMOSTÁTICA

Thermostatic/Thermostatique

Flexo 1,75 m

Flexibles / Flexibles

PVC acabado en plata
Anti twist
Fácil limpieza

Silver finished. Anti twist. Easy cleaning.
Finition argent. Anti torsion. Nettoyage facile

Control de temperatura

Temperature control / Contrôle de la température

Tope de seguridad para
temperaturas superiores a **38°C**
Evita quemaduras

Safety stop for temperatures higher than 38°C.
Avoid burns.

Arrêt de sécurité pour températures supérieures
à 38°C. Évite les brûlures

Control de salida del agua

Water outlet control / Contrôle de sortie d'eau

Teléfono | Rociador

Handset - Shower head
Douchette - Pomme de douche

Elegante bandeja blanca

Elegant white tray / Plate-forme blanc élégant

Permite al usuario dejar cómodamente sus champús y utensilios
de baño sin tener que instalar una repisa adicional.

Allows the end user to leave the shampoos without installing any additional shelf.

Permet à l'utilisateur de déposer ses articles de douche sans nécessité d'installer
un plateau supplémentaire



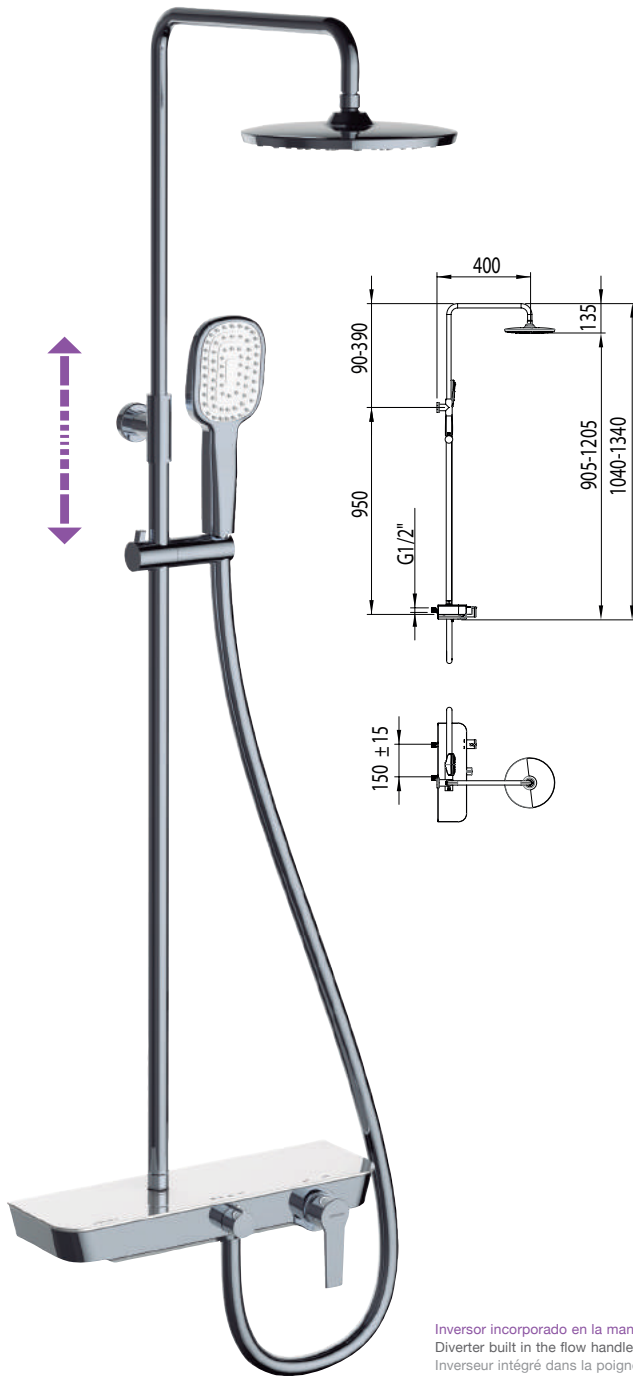

CONJUNTO DE DUCHA EXTENSIBLE | Extensible shower system | Colonne de douche extensible

Mezclador de ducha con tubo extensible Circular (98517), soporte articulado deslizable.
Adjustable shower valve with diverter built in.
Support douche coulissant, inverseur automatique, pomme de douche, douchette et flexible

Incluye
Includes
Inclus



Style Air
240x190
99606



Style Air
100x120
99611



Silver Hose
1,75 m
98880



Ceilan
96264

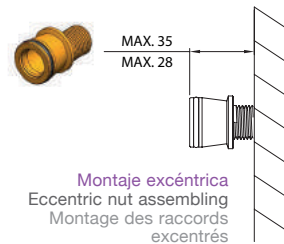

Montaje excéntrica
Eccentric nut assembling
Montage des raccords
excentrés

Ref.	€	📦
99732	518,00	4



Inversor incorporado en la maneta de caudal
Diverter built in the flow handle
Inverseur intégré dans la poignée

Productos relacionados
Related products
Produits connexes



PAG. 236

FLEXIBLE _ 97114
Cromado
Chrome plated
Chrome



PAG. 233

STYLE_ 99610
Teléfono ducha
Handset
Douchette



PAG. 222

SLIM INOX AIR_ 99600
Rociador 200x200
Shower head
Pomme de douche

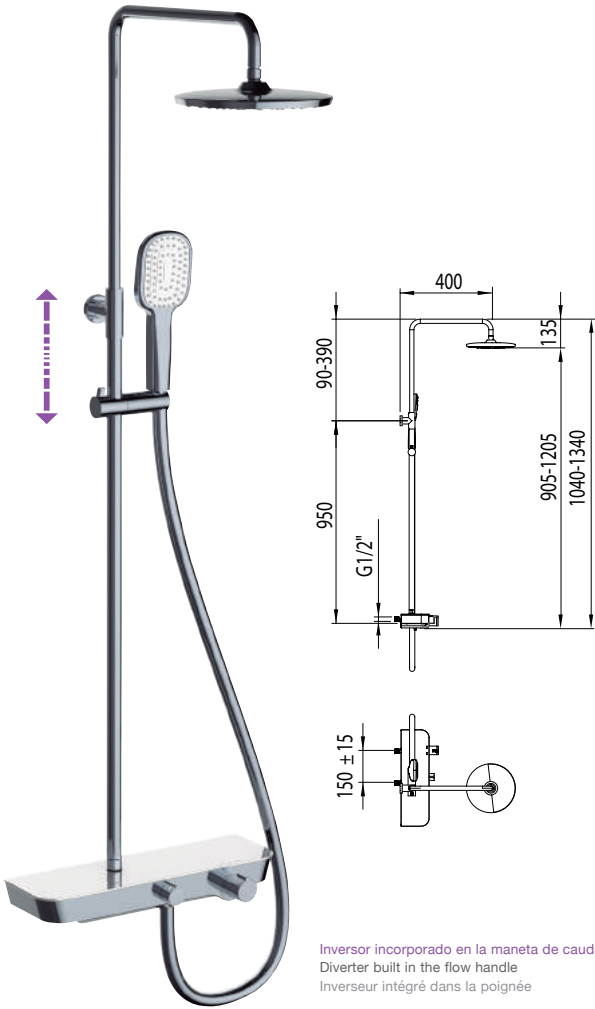

CONJUNTO DE DUCHA EXTENSIBLE TERMOSTÁTICO
Thermostatic Extensible shower system
Colonne de douche extensible thermostatique

Mezclador termostático de ducha con tubo extensible (98517), soporte articulado deslizable.
Adjustable thermostatic shower system (98517) with diverter built in.
Support douche coulissant, inverseur céramique, pomme de douche, douchette et flexible

Incluye
Includes
Inclus



Ref.	€	Q
99731	595,00	4

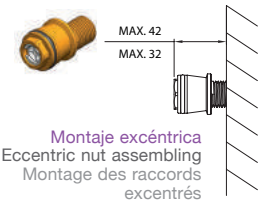
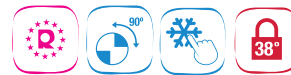

DUCHA TERMOSTÁTICA
Thermostatic shower mixer | Mitigeur douche thermostatique

Mezclador termostático para ducha.
Thermostatic shower mixer.
Mitigeur douche thermostatique

Incluye
Includes
Inclus



Ref.	€	Q
60154	383,00	4
60761	352,00	4

Sin kit ducha
Without shower kit
Sans kit de douche

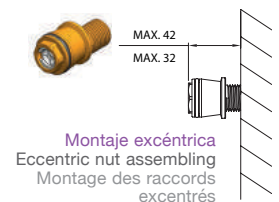
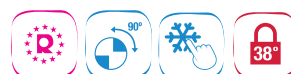

Nine xtreme



TERMOSTÁTICA

Thermostatic/Thermostatique

Control de temperatura
Temperature control / Contrôle de la température

Tope de seguridad para temperaturas superiores a **38°C**
Evita quemaduras
Safety stop for temperatures higher than 38°C.
Avoid burns.
Arrêt de sécurité pour températures supérieures à 38°C. Évite les brûlures



Control de salida del agua
Water outlet control / Contrôle de sortie d'eau

Teléfono | Rociador
para Conjunto de ducha extensible termostático
Handset - Shower head
for Thermostatic extensible shower system
Douchette - Pomme de douche
pour Colonne de douche extensible thermostatique

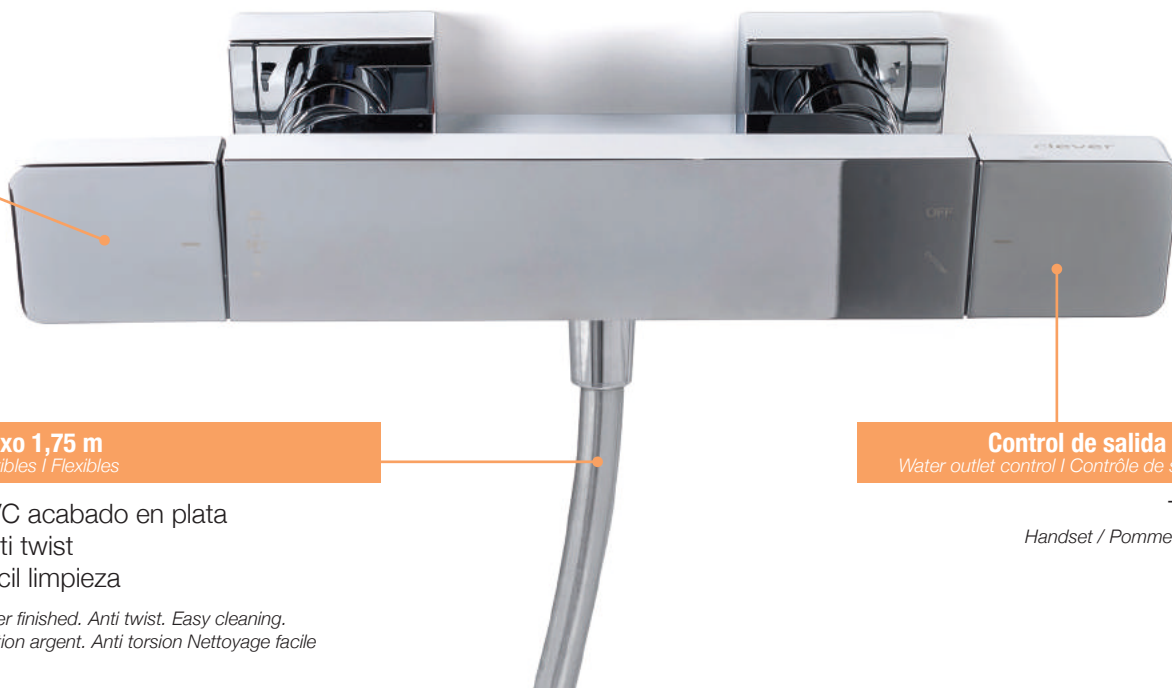

Flexo 1,75 m
Flexibles / Flexibles

PVC acabado en plata
Anti twist
Fácil limpieza

Silver finished. Anti twist. Easy cleaning.
Finition argent. Anti torsion Nettoyage facile

Control de salida del agua
Water outlet control / Contrôle de sortie d'eau

Teléfono
Handset / Pomme de douche



Soporte deslizante
Sliding support / Support coulissant



Nine xtreme

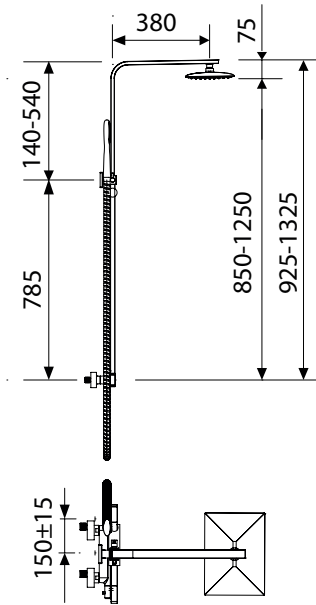

Inversor incorporado en la maneta de caudal
Diverter built in the flow handle
Inverseur intégré dans la poignée

NEW

CONJUNTO DE DUCHA EXTENSIBLE TERMOSTÁTICO Thermostatic Extensible shower system Colonne de douche extensible thermostatique

Incluye Kit ducha
Includes shower kit
Inclus kit de douche

Acabado en negro MATE.
Matt black finish.
Finition noir mat.

Ref.	€	
60791	592,00	4

Disponible en Abril de 2019
Available in April 2019
Disponible en Avril 2019

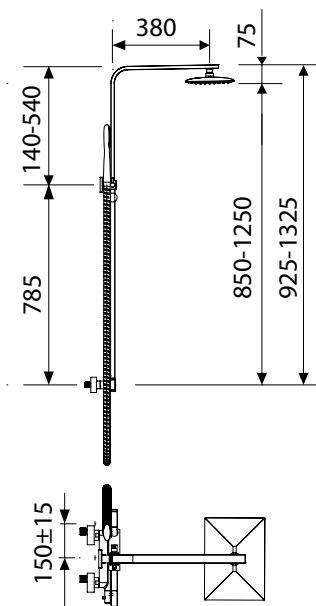

Inversor incorporado en la maneta de caudal
Diverter built in the flow handle
Inverseur intégré dans la poignée

CONJUNTO DE DUCHA EXTENSIBLE TERMOSTÁTICO Thermostatic Extensible shower system Colonne de douche extensible thermostatique

Incluye
Includes
Inclus



Ref.	€	
60135	512,00	4





DUCHA TERMOSTÁTICA
Thermostatic shower mixer
Mitigeur douche thermostatique

Mezclador para ducha.
 Shower mixer.
 Mitigeur douche thermostatique

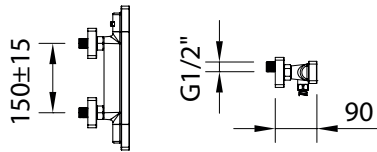

	Ref.	€	
Incluye Kit ducha Includes shower kit Inclus kit de douche	60133	290,00	6
Sin kit ducha Without shower kit Sans kit de douche	60134	259,00	6

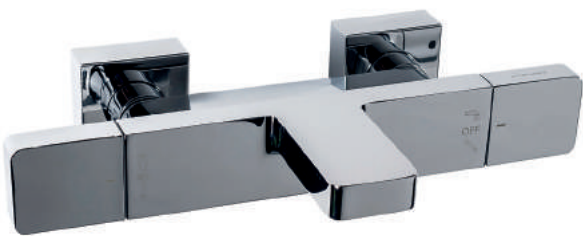

BAÑO-DUCHA TERMOSTÁTICO
Thermostatic bath-shower mixer
Mitigeur bain-douche thermostatique

Mezclador baño-ducha, aireador y inversor
 Bath-shower mixer, aerator and diverter built in.
 Mitigeur bain-douche thermostatique, aérateur et inverseur

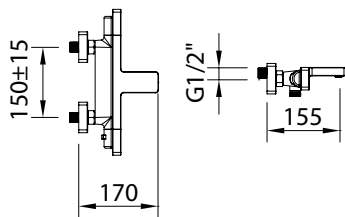

	Ref.	€	
Incluye Kit ducha Includes shower kit Inclus kit de douche	60131	342,00	6
Sin kit ducha Without shower kit Sans kit de douche	60132	311,00	6

Inversor incorporado en la maneta de caudal
 Diverter built in the flow handle
 Inverseur intégré dans la poignée



Productos relacionados
 Related products
 Produits connexes



FLEXIBLE _ 97114
 Cromado
 Chrome plated
 Chromé



MARINA _ 96786
 Teléfono ducha
 Handset
 Douchette

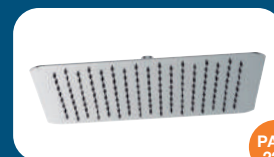

SLIM INOX AIR _ 99600
 Rociador 200x200
 Shower head
 Pomme de douche



98185
Lavabo
Basin Mixer
Mitiger Lavabo

STYLES



Agora *elegance*
52



Agora *xtreme*
54



Artic *xtreme*
58



Artic *urban*
62

Unlimited emotions

Unlimited designs



Caiman *elegance*
64



Caiman *xtreme*
68



Caiman *urban*
70



With2 *antigona*
74



With2 *morea*
78

Agora elegance

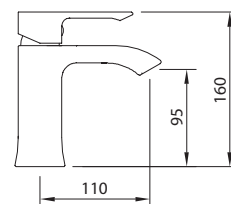
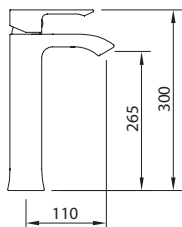

LAVABO 265

Tall basin mixer 265 | Mitigeur lavabo 265

Mezclador con aireador y flexibles M-10 3/8" x 370 mm.
Mixer, aerator, flexible hoses M-10 3/8" x 370 mm.
Mitigeur Lavabo bec haut, aérateur, raccords flexibles M-10 3/8" x 370 mm

Ref.	€	📦
98783	183,00	6



95183 98267 98774

LAVABO 95

Basin mixer 95 | Mitigeur lavabo 95

Mezclador con aireador y flexibles M-10 3/8" x 420 mm.
Mixer, aerator, flexible hoses M-10 3/8" x 420 mm.
Mitigeur Lavabo, aérateur, raccords flexibles M-10 3/8" x 420 mm

	Ref.	€	📦
	98680	140,00	12
	98685	148,00	12
	98686	156,00	12



95183 98267 98774

Productos relacionados

Related products
Produits connexes



PAG. 210

iclever basin_98703 + 98709
Lavabo empotrado
Concealed basin mixer
Lavabo encastré



PAG. 297

VELA_97395 96255
Válvula desagüe metálico
Drain quick-clac metallic
Vidage métallique



PAG. 296

ELEGANCE_96174
Sifón botella latón
Brass bottle trap
Siphon laiton



PAG. 296

DESIGN_40010
Válvula escuadra
Angle Valve / Robinet
d'équerre



BAÑO-DUCHA
Bath-shower mixer | Mitigeur bain-douche

Mezclador con aireador baño-ducha, inversor automático.
Bath-shower mixer with aerator, automatic diverter.
Mitigeur bain-douche, aérateur, inverseur automatique

	Ref.	€	8
Incluye teléfono ducha, flexo y soporte Includes handset, hose and holder Inclus douchette, flexible et support (97142, 97670, 96942)	98682	193,00	8
Sin kit ducha Without shower kit Sans kit de douche	98678	172,00	8



DUCHA
Shower mixer | Mitigeur douche

Mezclador para ducha.
Shower mixer.
Mitigeur douche

	Ref.	€	8
Incluye teléfono ducha, flexo y soporte Includes handset, hose and holder Inclus douchette, flexible et support (97142, 97670, 96942)	98683	161,00	8
Sin kit ducha Without shower kit Sans le kit de douche	98679	140,00	8

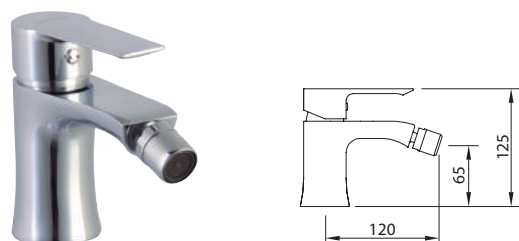

BIDÉ
Bidet mixer | Mitigeur bidet

Mezclador con aireador a rótula, flexibles M-10 3/8" x 420 mm.
Mixer, swivel aerator, flexible hoses M-10 3/8" x 420 mm.
Mitigeur bidet, aérateur rotule, raccords flexibles M-10 3/8" x 420 mm

	Ref.	€	12
SYNTHETIC	98681	140,00	12
METALLIC	98687	148,00	12
METALLIC	98688	156,00	12



FREGADERO
Sink mixer | Mitigeur évier

Mezclador con aireador, caño fundido giratorio, flexibles M-10 3/8" x 370 mm.
Mixer with aerator, swivel cast spout, flexible hoses M-10 3/8" x 370 mm.
Mitigeur évier bec orientable, aérateur, raccords flexibles M-10 3/8" x 370 mm

	Ref.	€	8
	98684	169,00	8



Tecnología
Technology / Technologie

AIREADOR ORIENTABLE para un mayor confort durante su uso

Orientable aerator for greater comfort during its use | Aérateur orientable pour plus de confort lors de l'utilisation



Agora xtreme



LAVABO 240

Tall basin mixer 240 Mitigeur lavabo 240

Mezclador con aireador y flexibles M-10 3/8" x 370 mm.
Mixer, aerator, flexible hoses M-10 3/8" x 370 mm.
Mitigeur Lavabo, aérateur, raccords flexibles M-10 3/8" x 370 mm

Ref.	€	📦
60103	173,00	8

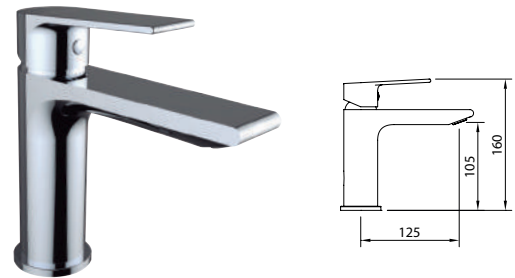

LAVABO 105

Basin mixer 105 | Mitigeur lavabo 105

Mezclador con aireador y flexibles M-10 3/8" x 420 mm.
Mixer, aerator, flexible hoses M-10 3/8" x 420 mm.
Mitigeur Lavabo, aérateur, raccords flexibles M-10 3/8" x 420 mm

	Ref.	€	📦
SYNTHETIC	60100	129,00	8
METALLIC	60101	137,00	8
METALLIC	60102	145,00	8



Productos relacionados Related products Produits connexes



PAG. 297

LEO BLANCO MATE _ 60701
Válvula desagüe Universal. Metálico
Universal drain quick-clac. Metallic
Vidage Universel. Métallique



PAG. 297

LEO NEGRO MATE _ 60702
Válvula desagüe Universal. Metálico
Universal drain quick-clac. Metallic
Vidage Universel. Métallique



PAG. 296

XTREME _ 96173
Sifón botella latón
Brass bottle trap
Siphon laiton



PAG. 296

XTREME _ 97106
Válvula escuadra
Angle Valve / Robinet
d'equerre



NEW

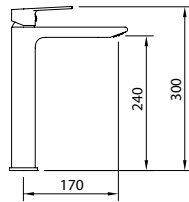

LAVABO 240 BLANCO MATE
Matte white tall basin mixer 240
Mitigeur lavabo blanc mat 240

Mezclador con aireador y flexibles M-10 3/8" x 370 mm.
 Mixer, aerator, flexible hoses M-10 3/8" x 370 mm.
 Mitigeur Lavabo, aérateur, raccords flexibles M-10 3/8" x 370 mm

Ref.	€	Icon
ACS ec2 60706	188,00	8

Acabado en blanco.
 White finish.
 Finition blanc.



NEW

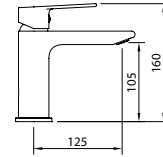

LAVABO 105 BLANCO MATE
Matte white basin mixer 105
Mitigeur lavabo blanc mat 105

Mezclador con aireador y flexibles M-10 3/8" x 420 mm.
 Mixer, aerator, flexible hoses M-10 3/8" x 420 mm.
 Mitigeur Lavabo, aérateur, raccords flexibles M-10 3/8" x 420 mm

Ref.	€	Icon
ACS ec2 60704	144,00	8

Acabado en blanco.
 White finish.
 Finition blanc.



NEW

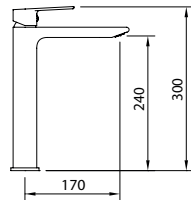

LAVABO 240 NEGRO MATE
Matte black tall basin mixer 240
Mitigeur lavabo noir mat 240

Mezclador con aireador y flexibles M-10 3/8" x 370 mm.
 Mixer, aerator, flexible hoses M-10 3/8" x 370 mm.
 Mitigeur Lavabo, aérateur, raccords flexibles M-10 3/8" x 370 mm

Ref.	€	Icon
ACS ec2 60707	188,00	8

Acabado en negro.
 Black finish.
 Finition noir.



NEW

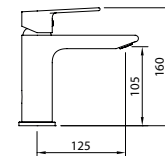

LAVABO 105 NEGRO MATE
Matte black basin mixer 105
Mitigeur lavabo noir mat 105

Mezclador con aireador y flexibles M-10 3/8" x 420 mm.
 Mixer, aerator, flexible hoses M-10 3/8" x 420 mm.
 Mitigeur Lavabo, aérateur, raccords flexibles M-10 3/8" x 420 mm

Ref.	€	Icon
ACS ec2 60705	144,00	8

Acabado en negro.
 Black finish.
 Finition noir.



Tecnología
 Technology / Technologie

AIREADOR ORIENTABLE para un mayor confort durante su uso

Orientable aerator for greater comfort during its use | Aérateur orientable pour plus de confort lors de l'utilisation

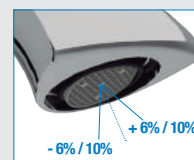
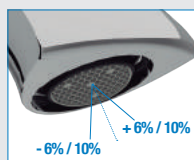
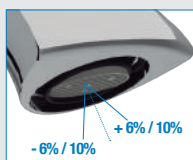

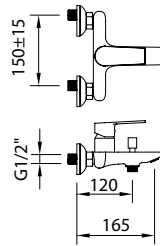
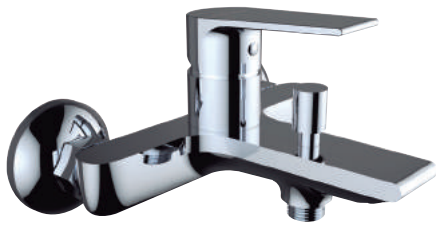

BAÑO-DUCHA Bath-shower mixer | Mitigeur bain-douche

Mezclador con aireador baño-ducha, inversor automático.
Bath-shower mixer with aerator, automatic diverter.
Mitigeur bain-douche, aérateur, inverseur automatique

Incluye teléfono ducha, flexo y soporte
Includes handset, hose and holder
Inclus douchette, flexible et support
(97142, 97670, 60311)

	Ref.	€	
	60109	182,00	8
	60110	161,00	8

Sin kit ducha
Without shower kit
Sans kit de douche

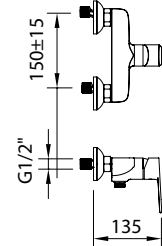

DUCHA Shower mixer | Mitigeur douche

Mezclador para ducha.
Shower mixer.
Mitigeur douche

Incluye teléfono ducha, flexo y soporte
Includes handset, hose and holder
Inclus douchette, flexible et support
(97142, 97670, 60311)

	Ref.	€	
	60111	151,00	8
	60112	130,00	8

Sin kit ducha
Without shower kit
Sans kit de douche

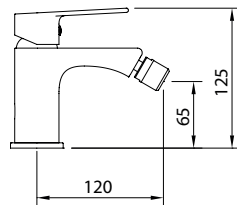

BIDÉ Bidet mixer | Mitigeur bidet

Mezclador con aireador a rótula, flexibles M-10 3/8" x 370 mm.
Mixer with aerator, swivel aerator, flexible hoses M-10 3/8" x 370 mm.
Mitigeur bidet, aérateur rotule, raccords flexibles M-10 3/8" x 370 mm

	Ref.	€	
	60106	129,00	8
	60107	137,00	8
	60108	145,00	8

SYNTHETIC
METALLIC

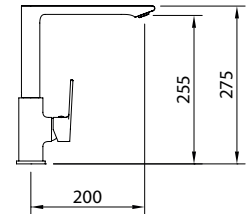

FREGADERO Sink mixer | Mitigeur évier

Mezclador con aireador, caño fundido giratorio, flexibles M-10 3/8" x 420 mm.
Mixer with aerator, swivel cast spout, flexible hoses M-10 3/8" x 420 mm.
Mitigeur évier bec orientable, aérateur, raccords flexibles M-10 3/8" x 420 mm.

	Ref.	€	
	60113	169,00	-



Productos relacionados
Related products
Produits connexes



PAG. 216

iclever 4_ 98742 + 98750
Ducha empotrada termostática
Thermostatic concealed bath-shower
Douche encastré thermostatique



PAG. 49

NINE XTREME_ 60133
Ducha termostática
Thermostatic shower mixer
Mitigeur douche thermostatique



PAG. 254

xtreme_ 98655
Accesorios de baño
Bathroom accessories
Accessoires de salle de bain



PAG. 226

TREND_ 99626
Conjunto barra ducha
Sliding bar set
Ensemble barre douche



60100
Lavabo 105
Basin mixer 105
Mitigeur lavabo 105

Artic xtreme

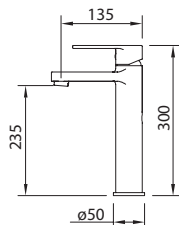

LAVABO 235

Tall basin mixer 235 | Mitigeur lavabo 235

Mezclador con aireador y flexibles M-10 3/8" x 370 mm.
Mixer, aerator, flexible hoses M-10 3/8" x 370 mm.
Mitigeur Lavabo bec haut, aérateur, raccords flexibles M-10 3/8" x 370 mm

	Ref.	€	📦
	98784	152,00	6

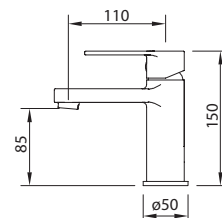

LAVABO 85

Basin mixer 85 | Mitigeur lavabo 85

Mezclador con aireador y flexibles M-10 3/8" x 420 mm.
Mixer, aerator, flexible hoses M-10 3/8" x 420 mm.
Mitigeur Lavabo, aérateur, raccords flexibles M-10 3/8" x 420 mm

	Ref.	€	📦
	98690	111,00	12
	98695	119,00	12
	98696	127,00	12

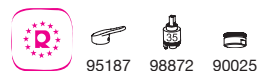

Productos relacionados

Related products
Produits connexes



PAG. 210

iclever basin _ 98703 + 98710
Lavabo empotrado
Concealed basin mixer
Lavabo encastré



PAG. 297

VELA _ 97395 96255
Válvula desagüe metálico
Drain quick-clac metallic
Vidage métallique



PAG. 296

ELEGANCE _ 96174
Sifón botella latón
Brass bottle trap
Siphon laiton



PAG. 296

DESIGN _ 40010
Válvula escuadra
Angle Valve / Robinet
d'equerre

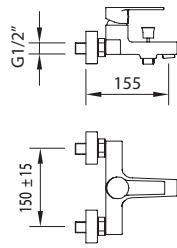

BAÑO-DUCHA
Bath-shower mixer | Mitigeur bain-douche

Mezclador baño-ducha, aireador, inversor automático
Bath-shower mixer, aerator, automatic diverter.
Mitigeur bain-douche, aérateur, inverseur automatique

Incluye teléfono ducha, flexo y soporte
Includes handset, hose and holder
Inclus douchette, flexible et support
(90796, 97670, 98208)

	Ref.	€	📦
	98692	158,00	8

Sin kit ducha
Without shower kit
Sans kit de douche

	98699	137,00	8
--	-------	--------	---

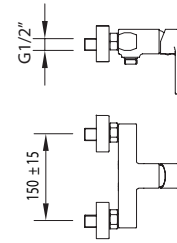

DUCHA
Shower mixer | Mitigeur douche

Mezclador para ducha.
Shower mixer.
Mitigeur douche

Incluye teléfono ducha, flexo y soporte
Includes handset, hose and holder
Inclus douchette, flexible et support
(90796, 97670, 98208)

	Ref.	€	📦
	98693	127,00	8

Sin kit ducha
Without shower kit
Sans kit de douche

	98700	106,00	8
--	-------	--------	---

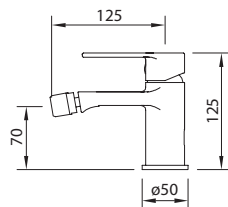

BIDÉ
Bidet mixer | Mitigeur bidet

Mezclador con aireador a rótula y flexibles M-10 3/8" x 420 mm.
Mixer, swivel aerator, flexible hoses M-10 3/8" x 420 mm.
Mitigeur bidet, aérateur rotule, raccords flexibles M-10 3/8" x 420 mm

	Ref.	€	📦
	98691	111,00	12
	98697	119,00	12
	98698	127,00	12



SISTEMA ECONATURE.
Ahorro de agua. Dos posiciones de apertura de la maneta.

Econature system. Save water. Two positions of opening the handle.
Système Econature. Économie d'eau. Deux positions d'ouverture de la poignée.

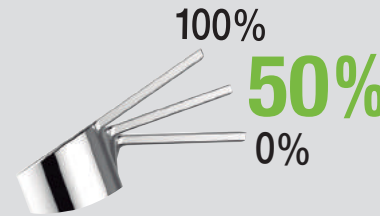

PAG. 256

Urban_99459
Accesorios de baño
Bathroom accessories
Accessoires de salle de bain



PAG. 212

Iclever 2_98711+98721
Ducha empotrada 1 vía
Concealed bath-shower 1 outlet diverter
Douche encastré 1 voie



PAG. 214

Iclever 2_98711+98736
Ducha empotrada 2 vías
Concealed bath-shower 2 outlet diverter
Douche encastré 2 voies



PAG. 233

STYLE_99613
Teléfono ducha
Handset
Douchette



PAG. 226

STYLE_99627
Conjunto ducha
Shower kit
Kit douche

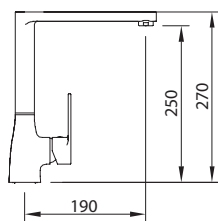

FREGADERO
Sink mixer | Mitigeur évier

Mezclador con aireador, caño fundido giratorio, flexibles M-10 3/8" x 370 mm.
Mixer with aerator, swivel cast spout, flexible hoses M-10 3/8" x 370 mm.
Mitigeur évier bec orientable, aérateur, raccords flexibles M-10 3/8" x 370 mm

	Ref.	€	
	98694	166,00	8

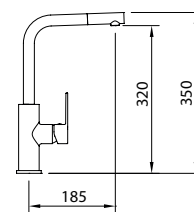

FREGADERO
Sink mixer | Mitigeur évier

Mezclador con aireador, caño giratorio, flexibles M-10 3/8" x 370 mm.
Mixer with aerator, swivel spout, flexible hoses M-10 3/8" x 370 mm.
Mitigeur évier bec orientable, aérateur, raccords flexibles M-10 3/8" x 370 mm

	Ref.	€	
	99108	155,00	4

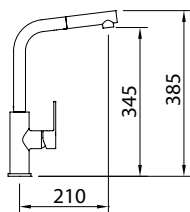

FREGADERO EXTRAÍBLE
Pull-out sink mixer | Mitigeur évier douche extractible

Mezclador con aireador, caño giratorio, ducha extraíble con pulsador para lavavajillas, enlaces de alimentación flexibles M-10 3/8" x 370 mm.
Mixer with aerator, swivel spout, pull-out handset and flexible hoses M-10 3/8" x 370 mm.
Mitigeur évier bec orientable, aérateur, douche extractible avec poussoir pré-lavage, raccords flexibles M-10 3/8" x 370 mm

	Ref.	€	
	98689	197,00	4



Tecnología
Technology | Technologie

SISTEMA COLD OPEN DE APERTURA EN FRÍO.
AHORRA EN AGUA CALIENTE.

Orientable aerator for greater comfort during its use.
Aérateur orientable pour plus de confort lors de l'utilisation.





98694
Fregadero
Sink Mixer
Mitiger Évier





Artic urban



LAVABO 250
Tall basin mixer 250 | Mitigeur lavabo 250

Mezclador con aireador y flexibles M-10 3/8" x 600 mm.
Mixer, aerator, flexible hoses M-10 3/8" x 600 mm.
Mitigeur Lavabo bec haut, aérateur, raccords flexibles M-10 3/8" x 600 mm

	Ref.	€	📦
 ec1	98103	175,00	12
 ec1	98112	183,00	12
 ec1	98111	191,00	12

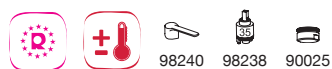

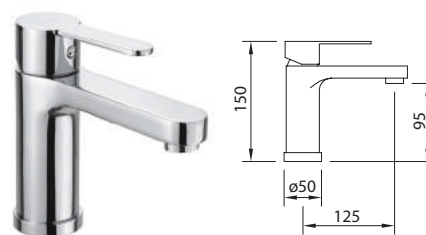

98240 98238 90025



LAVABO 95
Basin mixer 95 | Mitigeur lavabo 95

Mezclador con aireador y flexibles M-10 3/8" x 420 mm.
Mixer, aerator, flexible hoses M-10 3/8" x 420 mm.
Mitigeur Lavabo, aérateur, raccords flexibles M-10 3/8" x 420 mm

	Ref.	€	📦
 ec1	98102	131,00	12
 ec1	98110	139,00	12
 ec1	98109	147,00	12



98240 98238 90025

Productos relacionados Related products Produits connexes



PAG. 256

urban_99459
Accesorios de baño
Bathroom accessories
Accessoires de salle de bain



PAG. 297

VELA_97395_96255
Válvula desagüe metálico
Drain quick-clac metallic
Vidage métallique



PAG. 296

ELEGANCE_96174
Sifón botella latón
Brass bottle trap
Siphon laiton



PAG. 296

DESIGN_40010
Válvula escuadra
Angle Valve / Robinet
d'equerre

STYLES

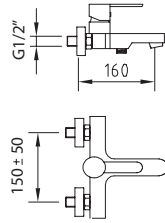

BAÑO-DUCHA

Bath-shower mixer | Mitigeur bain-douche

Mezclador baño-ducha, aireador, inversor integrado
Bath-shower mixer, aerator, hidden diverter.
Mitigeur bain-douche, aérateur, inverseur intégré

	Ref.	€	
Incluye teléfono ducha, flexo y soporte Includes handset, hose and holder Inclus douchette, flexible et support (90796, 97670, 96458)	ec1 98105	179,00	8
Sin kit ducha Without shower kit Sans kit de douche	ACS ec1 98541	158,00	8



98240 98238 96200 97817

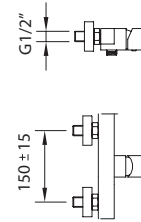

DUCHA

Shower mixer | Mitigeur Douche

Mezclador para ducha.
Shower mixer.
Mitigeur douche

	Ref.	€	
Incluye teléfono ducha, flexo y soporte Includes handset, hose and holder Inclus douchette, flexible et support (90796, 97670, 96458)	ec1 98106	148,00	8
Sin kit ducha Without shower kit Sans kit de douche	ACS ec1 98542	127,00	8



98240 98238

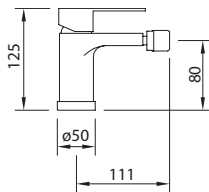

BIDÉ

Bidet mixer | Mitigeur bidet

Mezclador con aireador a rótula y flexibles M-10 3/8" x 420 mm.
Mixer, swivel aerator, flexible hoses M-10 3/8" x 420 mm.
Mitigeur bidet, aérateur rotule, raccords flexibles M-10 3/8" x 420 mm

	Ref.	€	
ACS	ec1 98104	131,00	12
ACS	ec1 98114	139,00	12
ACS	ec1 98113	147,00	12



98240 98238 90026

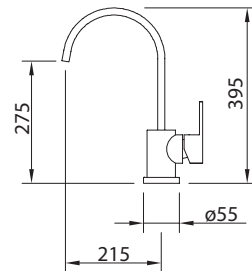

FREGADERO

Sink mixer | Mitigeur évier

Mezclador con aireador, caño conformado giratorio, flexibles M-10 3/8" x 420 mm.

Mixer with aerator, swivel tube spout, flexible hoses M-10 3/8" x 420 mm.
Mitigeur évier bec orientable, aérateur, raccords flexibles M-10 3/8" x 420 mm

	Ref.	€	
ACS	ec1 98107	166,00	5



98241 98238 90026 97688



PAG. 212

Iclever 2_ 98711+98717
Ducha empotrada 1 vía
Concealed bath-shower 1 outlet diverter
Douche encastré 1 voie



PAG. 214

Iclever 2_ 98711+98732
Ducha empotrada 2 vías
Concealed bath-shower 2 outlet diverter
Douche encastré 2 voies



PAG. 225

AUTOCLEAN_60305
Rociador
Shower head
Pomme de douche



PAG. 226

STYLE_99627
Conjunto ducha
Shower kit
Kit douche

Caiman elegance

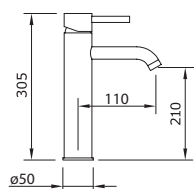

LAVABO 210

Tall basin mixer 210 | Mitigeur lavabo 210

Mezclador con aireador y flexibles M-10 3/8" x 600 mm.
Mixer, aerator, flexible hoses M-10 3/8" x 600 mm.
Mitigeur Lavabo bec haut, aérateur, raccords flexibles M-10 3/8" x 600 mm

	Ref.	€	📦
	ec1 97065	188,00	6

95132 96205 98600

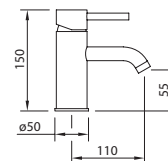

LAVABO 55

Basin mixer 55 | Mitigeur lavabo 55

Mezclador con aireador y flexibles M-10 3/8" x 370 mm.
Mixer, aerator, flexible hoses M-10 3/8" x 370 mm.
Mitigeur Lavabo, aérateur, raccords flexibles M-10 3/8" x 370 mm

	Ref.	€	📦
	ec1 97061	142,00	8
	ec1 97866	150,00	8
	ec1 97135	158,00	8

95132 96205 98600

Productos relacionados

Related products
Produits connexes



PAG. 210

iclever_98703 + 98707
Lavabo empotrado
Concealed basin mixer
Lavabo encastré



PAG. 297

VELA_97395_96255
Válvula desagüe metálico
Drain quick-clac metallic
Vidage métallique



PAG. 296

ELEGANCE_96174
Sifón botella latón
Brass bottle trap
Siphon laiton



PAG. 296

DESIGN_40010
Válvula escuadra
Angle Valve / Robinet
d'equerre

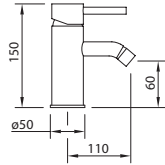

BIDÉ
Bidet mixer | Mitigeur bidet

Mezclador con aireador a rótula y flexibles M-10 3/8" x 370 mm.
Mixer, swivel aerator, flexible hoses M-10 3/8" x 370 mm.
Mitigeur bidet, aérateur rotule, raccords flexibles M-10 3/8" x 370 mm

	Ref.	€	
	ec1 97062	142,00	8
	ec1 97868	150,00	8
	ec1 97136	158,00	8

- 95132
- 96205
- 90026

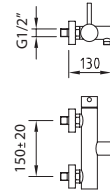

DUCHA
Shower mixer | Mitigeur Douche

Mezclador para ducha.
Shower mixer.
Mitigeur douche

Incluye teléfono ducha, flexo y soporte
Includes handset, hose and holder
Inclus douche, flexible et support
(90796, 97114, 97113)

	Ref.	€	
	ec1 60162	223,00	6

- 90761

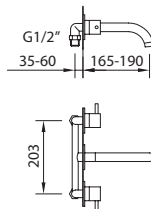

LAVABO EMPOTRADO MURAL
Concealed basin mixer | Mélangeur lavabo à encastrer

Mezclador empotrable de 1/2", caño mural con aireador, longitud 165-190 mm.
Concealed mixer 1/2" with aerator, wall spout length, 165-190 mm.
Mélangeur lavabo encastré, aérateur, bec 190 mm.

Ref.	€	
97076	217,00	8

- 95135



elegance_99451
Accesorios de baño
Bathroom accessories
Accessoires de salle de bain



Iclever 2_98711+98715
Ducha empotrada 1 vía
Concealed bath-shower 1 outlet diverter
Douche encastré 1 voie



Iclever 2_98711+98730
Ducha empotrada 2 vías
Concealed bath-shower 2 outlet diverter
Douche encastré 2 voies



AUTOCLEAN_60305
Rociador
Shower head
Pomme de douche



STYLE_99627
Conjunto ducha
Shower kit
Kit douche

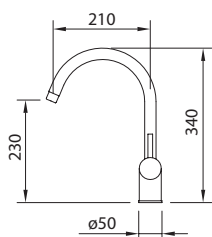

FREGADERO
Sink mixer | Mitigeur évier

Mezclador con aireador, caño conformado giratorio, flexibles M-10 3/8" x 370 mm.
Mixer with aerator, swivel tube spout, flexible hoses M-10 3/8" x 370 mm.
Mitigeur évier bec orientable, aérateur, raccords flexibles M-10 3/8" x 370 mm

	Ref.	€	📦
 ec1	97086	168,00	8

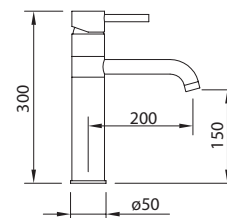

FREGADERO
Sink mixer | Mitigeur évier

Mezclador con caño giratorio con aireador y flexibles M-10 3/8" x 600 mm.
Mixer, aerator swivel spout, flexible hoses M-10 3/8" x 600 mm.
Mitigeur évier bec orientable, aérateur, raccords flexibles M-10 3/8" x 600 mm

	Ref.	€	📦
 ec1	60161	155,00	20

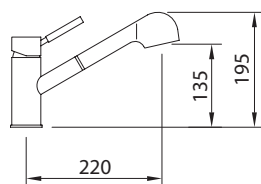
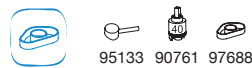

FREGADERO EXTRAÍBLE
Pull-out sink mixer | Mitigeur évier douchette extractible

Mezclador con aireador, caño giratorio, flexibles M-10 3/8" x 370 mm.
Mixer with aerator, swivel spout, flexible hoses M-10 3/8" x 370 mm.
Mitigeur évier bec orientable, aérateur, raccords flexibles M-10 3/8" x 370 mm

Incluye
Includes
Inclus



	Ref.	€	📦
Extraíble 90794	97069	199,00	8
1,50 m 96117	ec1		

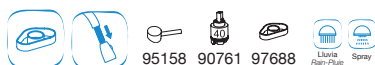

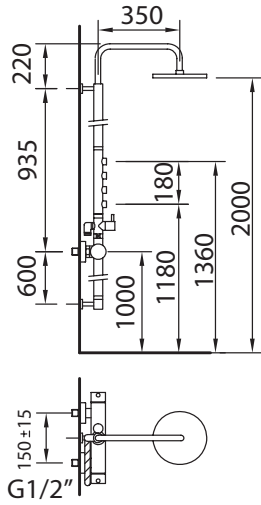

 NO EXTENSIBLE
NOT EXTENDABLE.
NON EXTENSIBLE

CONJUNTO DE DUCHA TERMOSTÁTICO 4 JETS
Thermostatic shower system 4 jets /
Colonne thermostatique douche hydromassage

Mezclador de ducha termostático, 4 rociadores frontales de hidromasaje, soporte articulado fijo.
Adjustable thermostatic shower system with diverter built in and body jets.
4 jets, support douchette fixe, inverseurs céramiques, pomme de douche, douchette et flexible.

Incluye
Includes
Inclus



Ø200
99637



Caiman
90796



1,80 m
97114

Ref.	€	
96436	1.113,00	4



98027



+ Termostático
Thermostatic / Thermostatique

+ Con **4 jets**
de hidromasaje

With 4 body jets / Avec 4 jets de massage





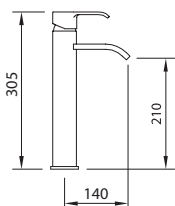

Caiman xtreme



LAVABO 210

Basin mixer 210 | Mitigeur lavabo 210

Mezclador alto con rompeaguas y flexibles M-10 3/8" x 370 mm.
Tall mixer, water breaker, flexible hoses M-10 3/8" x 370 mm.
Mitigeur lavabo bec haut, brise-jet, raccords flexibles M-10 3/8" x 370 mm

	Ref.	€	📦
 ec1	98186	173,00	6
  ec1	98193	181,00	6
  ec1	98194	189,00	6





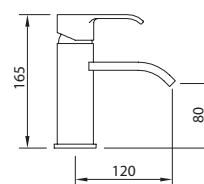

98212 98238



LAVABO 80

Basin mixer 80 | Mitigeur lavabo 80

Mezclador con rompeaguas y flexibles M-10 3/8" x 370 mm.
Basin mixer, water breaker, flexible hoses M-10 3/8" x 370 mm.
Mitigeur lavabo, brise-jet, raccords flexibles M-10 3/8" x 370 mm

	Ref.	€	📦
 ec1	98185	126,00	8
  ec1	98191	134,00	8
  ec1	98192	142,00	8



98212 98238

Productos relacionados

Related products
Produits connexes



PAG. 254

Xtreme_98655
Accesorios de baño
Bathroom accessories
Accessoires de salle de bain



PAG. 297

VELA_97395_96255
Válvula desagüe metálico
Drain quick-clac metallic
Vidage métallique



PAG. 296

ELEGANCE_96174
Sifón botella latón
Brass bottle trap
Siphon laiton



PAG. 296

DESIGN_40010
Válvula escuadra
Angle Valve / Robinet
d'equerre

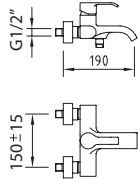

BAÑO-DUCHA
Bath-shower mixer | Mitigeur bain-douche

Mezclador baño-ducha, aireador, inversor integrado
Bath-shower mixer, aerator, hidden diverter.
Mitigeur bain-douche, aérateur, inverseur intégré

	Ref.	€	
Incluye teléfono ducha, flexo y soporte Includes handset, hose and holder Inclus douchette, flexible et support (90796, 97670, 96458)	ec1 98188	194,00	8
Sin kit ducha Without shower kit Sans kit de douche	ACS ec1 98543	173,00	8

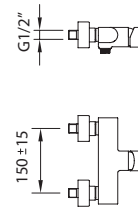

DUCHA
Shower mixer | Mitigeur Douche

Mezclador para ducha.
Shower mixer.
Mitigeur douche

	Ref.	€	
Incluye teléfono ducha, flexo y soporte Includes handset, hose and holder Inclus douchette, flexible et support (90796, 97670, 96458)	ec1 98189	162,00	6
Sin kit ducha Without shower kit Sans kit de douche	ACS ec1 98544	141,00	6

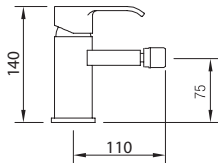

BIDÉ
Bidet mixer | Mitigeur bidet

Mezclador con aireador a rótula y flexibles M-10 3/8" x 370 mm.
Mixer, swivel aerator, flexible hoses M-10 3/8" x 370 mm.
Mitigeur bidet, aérateur rotule, raccords flexibles M-10 3/8" x 370 mm

	Ref.	€	
ACS	ec1 98187	126,00	8
SYNTHETIC ACS	ec1 98195	134,00	8
METALLIC ACS	ec1 98196	142,00	8

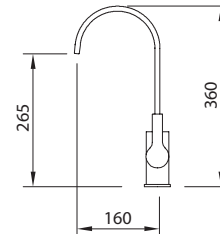

FREGADERO
Sink mixer | Mitigeur évier

Mezclador con aireador, caño giratorio, flexibles M-10 3/8" x 370 mm.
Mixer with aerator, swivel spout, flexible hoses M-10 3/8" x 370 mm.
Mitigeur évier bec orientable, aérateur, raccords flexibles M-10 3/8" x 370 mm

	Ref.	€	
ACS	ec1 98190	155,00	8



Iclever 2_98711+98718
Ducha empotrada 1 vía
Concealed bath-shower 1 outlet diverter
Douche encastré 1 voie



Iclever 2_98711+98733
Ducha empotrada 2 vías
Concealed bath-shower 2 outlet diverter
Douche encastré 2 voies



BEAM_60303
Rociador
Shower head
Pomme de douche



STYLE_99627
Conjunto ducha
Shower kit
Kit douche

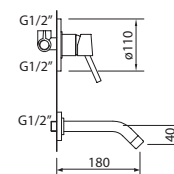
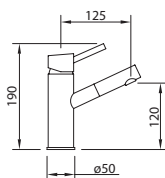

Caiman urban



LAVABO 120

Basin mixer 120 | Mitigeur lavabo 120

Mezclador con aireador y flexibles M-10 3/8" x 370 mm.
Mixer, aerator, flexible hoses M-10 3/8" x 370 mm.
Mitigeur Lavabo, aérateur, raccords flexibles M-10 3/8" x 370 mm

	Ref.	€	📦
	93510	121,00	8
	96511	129,00	8
	96561	137,00	8



LAVABO EMPOTRAR

Basin mixer | Mitigeur lavabo

Mezclador empotrable de 1/2", caño mural de 1/2", con aireador, longitud 180 mm.
Concealed mixer 1/2" with aerator, wall spout length 1/2", 180 mm.
Mitigeur lavabo encastré, aérateur, bec 180 mm.

	Ref.	€	📦
	96468	111,00	8

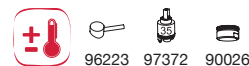

Productos relacionados

Related products
Produits connexes



urban_99459
Accesorios de baño
Bathroom accessories
Accessoires de salle de bain



VELA_97395_96255
Válvula desagüe metálico
Drain quick-clac metallic
Vidage métallique



ELEGANCE_96174
Sifón botella latón
Brass bottle trap
Siphon laiton



DESIGN_40010
Válvula escuadra
Angle Valve / Robinet
d'equerre



BAÑO-DUCHA
Bath-shower mixer | Mitigeur bain-douche

Mezclador baño-ducha, aireador, inversor automático
Bath-shower mixer, aerator, automatic diverter.
Mitigeur bain-douche, aérateur, inverseur automatique

	Ref.	€	
Incluye teléfono ducha, flexo y soporte Includes handset, hose and holder Inclus douchette, flexible et support (90796, 97670, 96458)	ec2 93512	266,00	6
Sin kit ducha Without shower kit Sans kit de douche	ACS ec2 97899	245,00	6



DUCHA
Shower mixer | Mitigeur Douche

Mezclador para ducha.
Shower mixer.
Mitigeur douche

	Ref.	€	
Incluye teléfono ducha, flexo y soporte Includes handset, hose and holder Inclus douchette, flexible et support (90796, 97670, 96458)	ec2 93513	214,00	8
Sin kit ducha Without shower kit Sans kit de douche	ACS ec2 97900	193,00	8

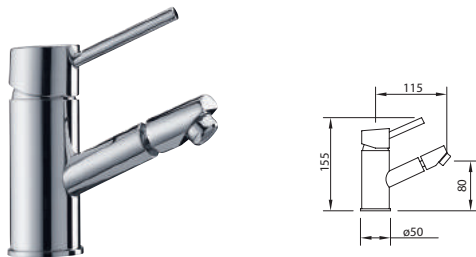
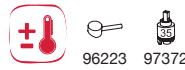

BIDÉ
Bidet mixer | Mitigeur bidet

Mezclador con aireador a rótula y flexibles M-10 3/8" x 370 mm.
Mixer, swivel aerator, flexible hoses M-10 3/8" x 370 mm.
Mitigeur bidet, aérateur rotule, raccords flexibles M-10 3/8" x 370 mm

	Ref.	€	
ACS ec2	93511	121,00	8
ACS ec2	96512	129,00	8
ACS ec2	96562	137,00	8

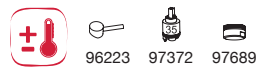

Iclever 2_98711+98719
Ducha empotrada 1 vía
Concealed bath-shower 1 outlet diverter
Douche encastré 1 voie



STYLE_99627
Conjunto ducha
Shower kit
Kit douche



Iclever 2_98711+98734
Ducha empotrada 2 vías
Concealed bath-shower 2 outlet diverter
Douche encastré 2 voies



CAIMAN_90796
Teléfono ducha
Handset
Douchette

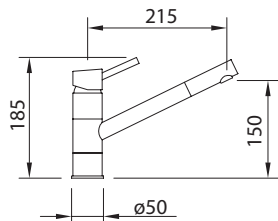

FREGADERO

Sink mixer | Mitigeur évier

Mezclador con caño giratorio con aireador y flexibles M-10 3/8" x 370 mm.
Mixer, aerator swivel spout, flexible hoses M-10 3/8" x 370 mm.
Mitigeur évier bec orientable, aérateur, raccords flexibles M-10 3/8" x 370 mm

	Ref.	€	
 	92603	131,00	8

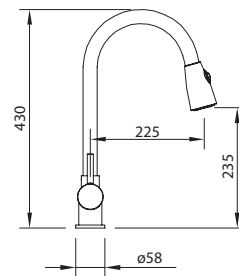

FREGADERO EXTRAIBLE

Pull-out sink mixer | Mitigeur évier douchette extractible

Mezclador con aireador, caño giratorio, ducha extraíble con pulsador para lavavajillas, enlaces de alimentación flexibles M-10 3/8" x 370 mm.
Mixer with aerator, swivel spout, pull-out handshower and flexible hoses M-10 3/8" x 370 mm.
Mitigeur évier bec orientable, douchette extractible, aérateur, raccords flexibles M-10 3/8" x 370 mm

	Ref.	€	
	97804	219,00	4

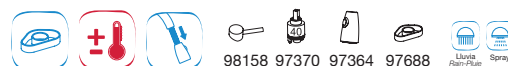



93510
Lavabo
Basin Mixer
Mitiger Lavabo



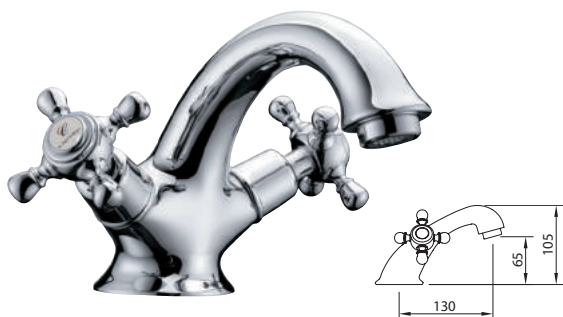

With2 antigona



LAVABO 65
Basin mixer 65 | Mélangeur lavabo 65

Mezclador con aireador y flexibles M-10 3/8" x 370 mm.
Mixer, aerator, flexible hoses M-10 3/8" x 370 mm.
Mélangeur lavabo, aérateur, raccords flexibles M-10 3/8" x 370 mm

	Ref.	€	📦
	94474	72,00	12
 ACS	96545	80,00	12
 ACS	97927	88,00	12





94600 96208 90025



LAVABO REPISA 105
Three hole deck basin 105 | Mélangeur lavabo 3 trous 105

Grifería mezcladora de repisa con aireador, caño alto. Flexible 300 mm
Three-hole basin mixer with aerator. Flexible hoses 300 mm
Mélangeur lavabo 3 trous, aérateur. Flexible 300 mm

	Ref.	€	📦
	98426	184,00	8
	98427	192,00	8
	98428	200,00	8

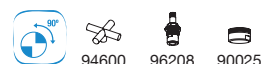

94600 96208 90025

Productos relacionados Related products Produits connexes



PAG. 258

Urban_98650
Accesorios de baño
Bathroom accessories
Accessoires de salle de bain



PAG. 297

LEO_98674
Válvula desague Universal
Universal drain quick-clac
Vidage Universel



PAG. 296

URBAN_90755
Sifón botella latón
Brass bottle trap
Siphon laiton



PAG. 296

DESIGN_40010
Válvula escuadra
Angle Valve
Robinet d'equerre

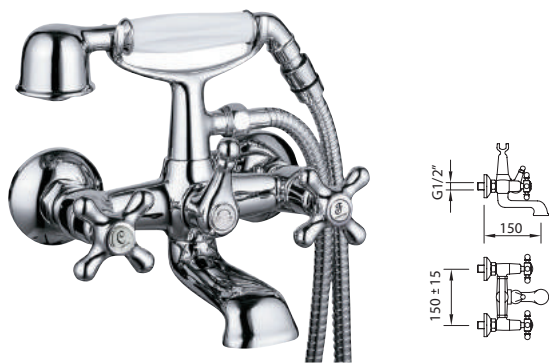

BAÑO-DUCHA
Bath-shower mixer | Mitigeur bain-douche

Mezclador baño-ducha, inversor
Bath-shower mixer, diverter.
Mélangeur bain-douche, inverseur

	Ref.	€	📦
Incluye teléfono ducha, flexo Includes handset, hose Inclus douchette, flexible (90758, 97670)	94476	126,00	8
Sin kit ducha Without shower kit Sans kit de douche	97929	105,00	8



DUCHA
Shower mixer | Mitigeur Douche

Mezclador para ducha.
Shower mixer.
Mitigeur douche

	Ref.	€	📦
Incluye teléfono ducha, flexo Includes handset, hose Inclus douchette, flexible (90758, 97670, 96159)	94477	81,00	12
Sin kit ducha Without shower kit Sans kit de douche	97930	60,00	12



GRIFO SIMPLE REPISA 40
Single washbasin tap 40 | Robinet simple 40

Grifo de repisa con aireador.
Deck mounted single basin tap, with aerator.
Robinet lavabo, aérateur, 1/2"

	Ref.	€	📦
	94489	27,00	24



LAVABO EMPOTRADO MURAL
Concealed basin mixer | Mélangeur lavabo mural 3 trous

Mezclador empotrable de 1/2", caño mural con aireador, longitud 180 mm.
Concealed mixer 1/2" with aerator, wall spout length 180 mm.
Mélangeur lavabo encastré, aérateur, bec 180 mm.

	Ref.	€	📦
	98429	151,00	8

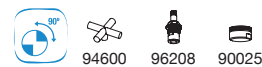

PAG. 235

TONGA_97113
Soporte articulado
Articulated holder
Support douchette orientable

PAG. 234

ANTIGONA_90758
Teléfono ducha
Handset
Douchette

PAG. 223

TAMP_96437
Rociador
Shower head
Pomme de douche

PAG. 226

STYLE_99627
Conjunto ducha
Shower kit
Kit douche

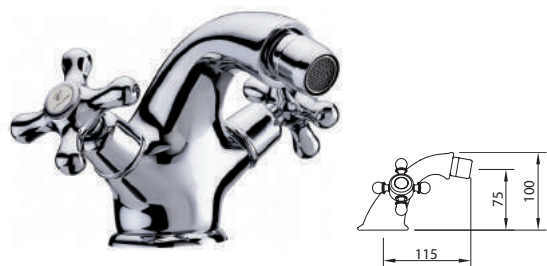

BIDÉ
Bidet mixer | Mélangeur bidet

Mezclador con aireador a rótula y flexibles M-10 3/8" x 370 mm.
Mixer, swivel aerator, flexible hoses M-10 3/8" x 370 mm.
Mélangeur bidet, aérateur rotule, raccords flexibles M-10 3/8" x 370 mm

	Ref.	€	📦
	94475	72,00	12
	96546	80,00	12
	97928	88,00	12



FREGADERO
Sink mixer | Mitigeur évier

Mezclador con aireador, caño conformado giratorio, flexibles M-10 3/8" x 370 mm.
Mixer with aerator, swivel tube spout, flexible hoses M-10 3/8" x 370 mm.
Mélangeur évier, bec orientable, aérateur, raccords flexibles M-10 3/8" x 370 mm

	Ref.	€	📦
	92049	65,00	8

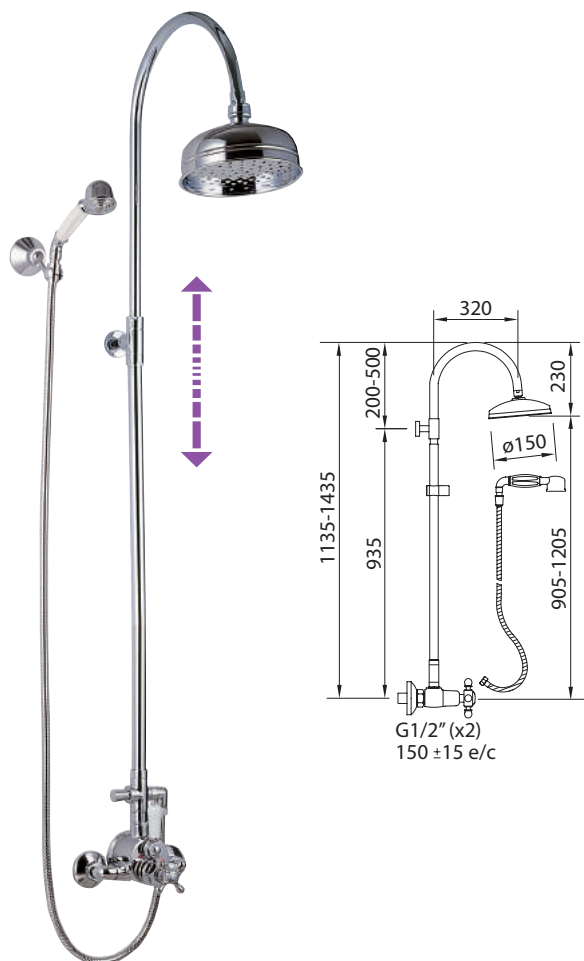

CONJUNTO DE DUCHA TERMOSTÁTICO EXTENSIBLE
Extensible Thermostatic shower system
Colonne thermostatique douche extensible

Mezclador de ducha termostático con tubo extensible Cross (96118).
Adjustable Thermostatic bath-shower system Cross (96118) with diverter and fixed handset.
Support douchette orientable, inverseur automatique, pomme de douche, douchette et flexible

Incluye
Includes
Inclus



Ref.	€	📦
96746	576,00	3



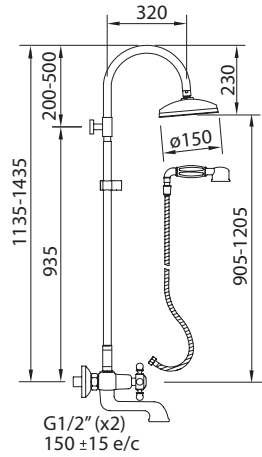

Inversor incorporado en la maneta de caudal
Integral diverter in the flow handle
Inverseur intégré dans la poignée

CONJUNTO DE BAÑO-DUCHA EXTENSIBLE
Extensible bath-shower system
Colonne mélangeur bain-douche extensible

Mezclador de baño-ducha con tubo extensible Cross (96118).
Adjustable bath-shower system Cross (96118) with diverter and fixed handset.
Support douchette orientable, inverseur manuel/automatique, pomme de douche, douchette et flexible

Incluye
Includes
Inclus



New Tampa
96437



Antigona
90758



1,75 m
97670



Antigona
96159



Support
98497



Antao
96120

Ref.	€	
96747	500,00	3



94600



96208



95051

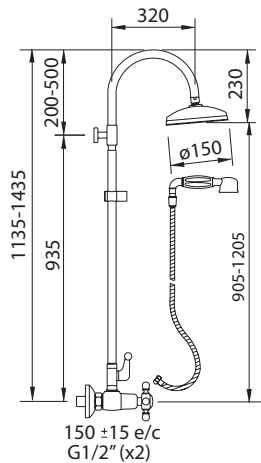

CONJUNTO DE DUCHA EXTENSIBLE
Extensible shower system | *Colonne mélangeur douche extensible*

Mezclador de ducha con tubo extensible Cross (96118).
Adjustable shower system Cross (96118) with diverter and fixed handset.
Support douchette orientable, inverseur manuel, pomme de douche, douchette et flexible

Incluye
Includes
Inclus



New Tampa
96437



Antigona
90758



1,75 m
97670



Antigona
96159



Support
98497

Ref.	€	
96154	455,00	3



94600



96208



95051

Productos relacionados
Related products
Produits connexes



PAG. 236

SILVER HOSE _ 98880
Flexible. Acabado en plata
Flexible. Silver finish
Flexible. Finition argent



PAG. 236

FLEXIBLE _ 97114
Cromado
Chrome plated
Chrome



PAG. 223





ROUND AIR _ 99604
Rociador ø 120mm
Shower head
Pomme de douche

With2 morea



LAVABO 175
Basin mixer 175 | Mélangeur lavabo 175



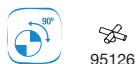

Mezclador alto con aireador y flexibles M-10 3/8" x 370 mm.
Tall mixer with aerator, flexible hoses M-10 3/8" x 370 mm.
Mélangeur lavabo, aérateur, raccords flexibles M-10 3/8" x 370 mm

	Ref.	€	📦
	97001	152,00	8
 	97881	160,00	8
 	97125	168,00	8



LAVABO REPISA 180
Three hole deck basin | Mélangeur lavabo 3 trous

Grifería mezcladora de repisa con aireador, caño alto 180mm.
Three-hole basin mixer with aerator spout 180mm.
Mélangeur lavabo 3 trous, aérateur

	Ref.	€	📦
	97006	232,00	6
 	97885	240,00	6
 	97127	248,00	6

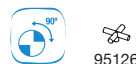

Productos relacionados
Related products
Produits connexes



Urban_ 98650
Accesorios de baño
Bathroom accessories
Accessoires de salle de bain



VELA_ 97395_96255
Válvula desagüe metálico
Drain quick-clac metálico
Vidage métallique



ELEGANCE_ 96174
Sifón botella latón
Brass bottle trap
Siphon laiton





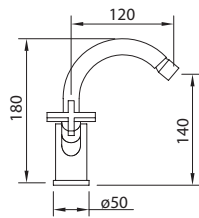

DESIGN_ 40010
Válvula escuadra
Angle Valve
Robinet d'equerre



BIDÉ

Bidet mixer | Mélangeur bidet

Mezclador con aireador a rótula y flexibles M-10 3/8" x 370 mm.
Mixer, swivel aerator, flexible hoses M-10 3/8" x 370 mm.
Mélangeur bidet, aérateur rotule, raccords flexibles M-10 3/8" x 370 mm

	Ref.	€	📦
	97002	152,00	8
 	97882	160,00	8
 	97126	168,00	8

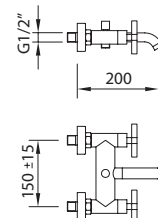
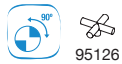

BAÑO-DUCHA

Bath-shower mixer | Mitigeur bain-douche

Mezclador baño-ducha, aireador, inversor automático
Bath-shower mixer, aerator, automatic diverter.
Mélangeur bain-douche, aérateur, inverseur

	Ref.	€	📦
Incluye teléfono ducha, flexo y soporte Includes handset, hose and holder Inclus douchette, flexible et support (90796, 97114, 97113)	97003	243,00	6
Sin kit ducha Without shower kit Sans kit de douche	97883	222,00	6

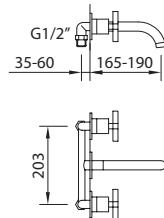

LAVABO EMPOTRAR

**Concealed basin mixer
Mélangeur lavabo à encastrer**

Mezclador empotrable, caño mural con aireador.
Concealed basin mixer, spout with aerator.
Mélangeur lavabo encastré, aérateur, bec 190 mm.

	Ref.	€	📦
	97007	232,00	6

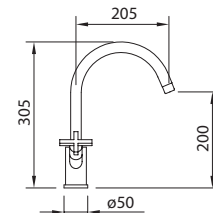

FREGADERO

Sink mixer | Mitigeur évier

Mezclador con aireador, caño giratorio, flexibles M-10 3/8" x 370 mm.
Mezclador con aireador, caño conformado giratorio, flexibles M-10 3/8" x 370 mm.
Mixer with aerator, swivel tube spout, flexible hoses M-10 3/8" x 370 mm.
Mélangeur évier, bec orientabl, eaérateur, raccords flexibles M-10 3/8" x 370 mm

	Ref.	€	📦
	97005	152,00	8



PAG. 236

SILVER HOSE_ 98880
Flexible. Acabado en plata
Flexible. Silver finish
Flexible. Finition argent



PAG. 224

BEAM_ 60303
Rociador
Shower head
Pomme de douche



PAG. 233

BEAM_ 60304
Teléfono de ducha
Handset
Douchette



PAG. 226

STYLE 99627
Conjunto ducha
Shower kit
Kit douche

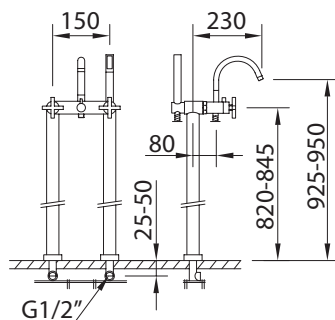

BAÑO-DUCHA FIJACIÓN SUELO

Floor standing bath-shower mixer I

Mélangeur bain-douche sur colonnes avec prise d'eau au sol

Baño ducha fijación suelo, aireador, inversor.
 Floor standing bath-shower mixer, aerator, diverter.
 Mélangeur bain-douche sur colonne avec prise d'eau au sol,
 aérateur, inverseur automatique

Incluye
 Includes
 Inclus



Caiman
 90796



1,80 m
 97114

Ref.	€	📦
97020	702,00	6



95126

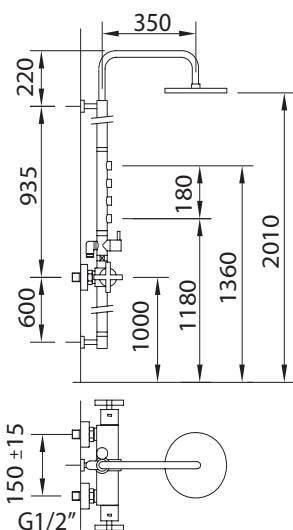

CONJUNTO DE DUCHA TERMOSTÁTICO 4 JETS

Thermostatic shower system 4 jets

Colonne thermostatique douche hydromassage

Mezclador de ducha termostático, 4 rociadores frontales de hidromasaje, soporte articulado fijo.
 Adjustable thermostatic shower system with diverter built in and body jets.
 4 jets, support douchette fixe, inverseurs céramiques, pomme de douche, douchette et flexible

Incluye
 Includes
 Inclus



Ø200
 97109



Caiman
 90796



1,80 m
 97114

Ref.	€	📦
97018	1.113,00	4



98027

⚠️ NO EXTENSIBLE
 NOT EXTENSIBLE.
 NON EXTENSIBLE



97018

Conjunto ducha termostático 4 jets
Thermostatic shower system 4 jets
Colonne thermostatique douche hydromassage



60535
 Lavabo
 Basin Mixer
 Mitiger Lavabo

STYLES PRO



Bahama **xtreme**
 84
 NF



Habana **xtreme**
 88



Start **elegance**
 92
 NF



Start **xtreme**
 96
 NF



Start **urban**
 100
 NF



S12 **elegance**
 122
 NF



S12 **xtreme**
 126
 NF



S12 **urban**
 130
 NF NF

Be versatile, keep it simple

Our basics



Panam Evo *elegance*
104
NEW



Panam Evo *xtreme*
108
NEW



Panam Evo *urban*
112
NEW



Panam *urban*
118



With2 *guayama*
136



Nine *urban*
140

Bahama xtreme

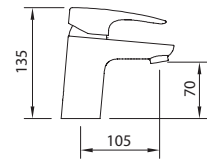
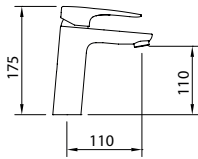

LAVABO 110

Basin mixer 110 | Mitigeur lavabo 110

Mezclador con aireador y flexibles M-10 3/8" x 500 mm.
Mixer, aerator, flexible hoses M-10 3/8" x 500 mm.
Mitigeur lavabo, aérateur, raccords flexibles M-10 3/8" x 500 mm

LAVABO 70

Basin mixer 70 | Mitigeur lavabo 70

Mezclador con aireador y flexibles M-10 3/8" x 420 mm.
Mixer, aerator, flexible hoses M-10 3/8" x 420 mm.
Mitigeur lavabo, aérateur, raccords flexibles M-10 3/8" x 420 mm

	Ref.	€	📦
	99185	95,00	12
	99186	97,00	12
	99187	99,00	12
	99188	103,00	12
	99189	105,00	12
	99190	107,00	12
	99191	111,00	12
	99192	113,00	12
	99193	115,00	12

	Ref.	€	📦
	99145	83,00	12
	98910	85,00	12
	98175	87,00	12
	99146	91,00	12
	98911	93,00	12
	98181	95,00	12
	99147	99,00	12
	98912	101,00	12
	98182	103,00	12



98209 C1-C2
95190 C3
98870 C1
98781 C2
98902 C3
99229



98209 C1-C2
95190 C3
98870 C1
98781 C2
98902 C3
99229

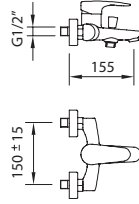

BAÑO-DUCHA
Bath-shower mixer | Mitigeur bain-douche

Mezclador con aireador baño-ducha, inversor automático.
Bath-shower mixer with aerator, automatic diverter.
Mitigeur bain-douche, aérateur, inverseur automatique.

Incluye teléfono ducha, flexo y soporte
Includes handset, hose and holder
Inclus douchette, flexible et support
(96108, 97670, 98208)

	ec1	98177	150,00	8
--	-----	-------	--------	---

Sin kit ducha
Without shower kit
Sans kit de douche

		C1	98282	135,00	8
--	--	----	-------	--------	---

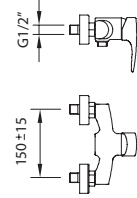

DUCHA
Shower mixer | Mitigeur douche

Mezclador para ducha.
Shower mixer.
Mitigeur douche

Incluye teléfono ducha, flexo y soporte
Includes handset, hose and holder
Inclus douchette, flexible et support
(96108, 97670, 98208)

	ec1	98178	119,00	8
--	-----	-------	--------	---

Sin kit ducha
Without shower kit
Sans kit de douche

		C1	98283	104,00	8
--	--	----	-------	--------	---

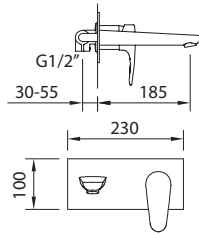

LAVABO EMPOTRAR
Concealed basin | Mitigeur lavabo à encastrer

Mezclador empotrable, caño mural con aireador, longitud 185 mm.
Concealed basin, aerator, wall mounted spout length 185 mm.
Mitigeur lavabo encastré, aérateur, bec 185 mm.

Ref.	€	
ec1 98423	182,00	6

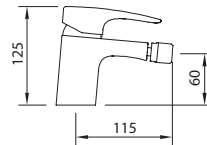

BIDÉ
Bidet mixer | Mitigeur bidet

Mezclador con aireador a rótula, flexibles M-10 3/8" x 370 mm.
Mixer, swivel aerator, flexible hoses M-10 3/8" x 370 mm.
Mitigeur bidet, aérateur rotule, raccords flexibles M-10 3/8" x 370 mm

	Ref.	€				
			98176	85,00	12	
				98183	93,00	12
				98184	101,00	12



Productos relacionados
Related products
Produits connexes



PAG. 256

urban_99459
Accesorios de baño
Bathroom accessories
Accessoires de salle de bain



PAG. 297

LEO_98674
Válvula desagüe Universal
Universal drain quick-clac
Vidage Universel



PAG. 214

Icelever 2_98711+98738
Ducha empotrada 2 vías
Concealed bath-shower 2 outlet diverter
Douche encastré 2 voies



PAG. 266

elegance_60740
Grifo electrónico
Sensor tap
Lavabo électronique

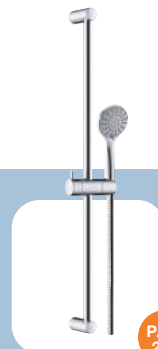

PAG. 226

CITY AIR_99624
Conjunto ducha
Shower kit
Kit douche

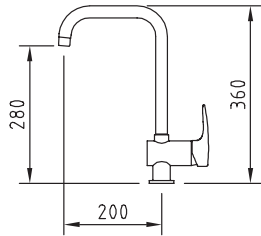

FREGADERO
Sink mixer | Mitigeur évier

Mezclador con aireador, caño conformado giratorio y flexibles M-10 3/8" x 420 mm.
Mixer, aerator, swivel tube spout, flexible hoses M-10 3/8" x 420 mm.
Mitigeur évier bec orientable, aérateur, raccords flexibles M-10 3/8" x 420 mm

	Ref.	€	📦
	98913	153,00	8
	98179	158,00	8

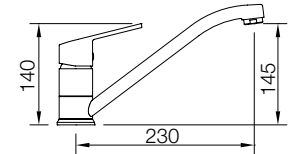
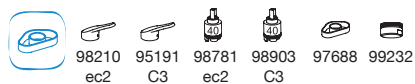

FREGADERO HORIZONTAL
Horizontal sink mixer | Mitigeur évier

Mezclador con aireador, caño giratorio y flexibles M-10 3/8" x 370 mm.
Mixer, aerator, swivel spout flexible hoses M-10 3/8" x 370 mm.
Mitigeur évier bec orientable, aérateur, raccords flexibles M-10 3/8" x 370 mm

	Ref.	€	📦
	99944	87,00	8
	99945	91,00	8

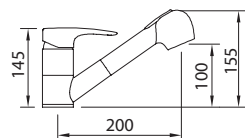
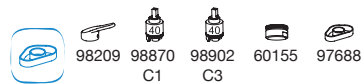

FREGADERO EXTRAÍBLE
Pull-out sink mixer | Mitigeur évier avec douchette extractible

Mezclador con aireador, caño giratorio, ducha extraíble con pulsador para lavavajillas, enlaces de alimentación flexibles M-10 3/8" x 370 mm.
Mixer with aerator, swivel spout, pull-out handshower and flexible hoses M-10 3/8" x 370 mm.
Mitigeur évier bec orientable, douchette extractible, aérateur, raccords flexibles M-10 3/8" x 370 mm

	Ref.	€	📦
	98180	164,00	8

Incluye Includes Inclus
2 Functions 90794 96117



SISTEMA COLD OPEN
DE APERTURA EN FRÍO.
AHORRA EN AGUA CALIENTE.

Orientable aerator for greater comfort during its use.
Aérateur orientable pour plus de confort lors de l'utilisation.



SISTEMA ECONATURE
AHORRO DE AGUA.
DOS POSICIONES DE APERTURA
DE LA MANETA.

Econature system. Save water.
Two positions of opening the handle.
Système Econature. Economie d'eau.
Deux positions d'ouverture de la poignée.

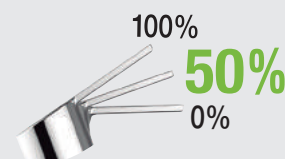



98175
Lavabo
Basin Mixer
Mitiger Lavabo



Habana xtreme

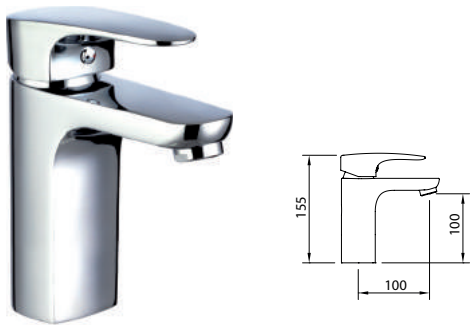

LAVABO 100

Tall basin mixer 100 | Mitigeur lavabo 100

Mezclador con aireador y flexibles M-10 3/8" x 500 mm.
Mixer, aerator, flexible hoses M-10 3/8" x 500 mm.
Mitigeur lavabo, aérateur, raccords flexibles M-10 3/8" x 500 mm

		Ref.	€	📦
ACS	ec1	99195	89,00	12
	ec2	99196	91,00	12
	ec3	99197	93,00	12
SYNTHETIC	ACS ec1	99198	97,00	12
	ACS ec2	99199	99,00	12
	ACS ec3	99200	101,00	12
METALLIC	ACS ec1	99201	105,00	12
	ACS ec2	99202	107,00	12
	ACS ec3	99203	109,00	12

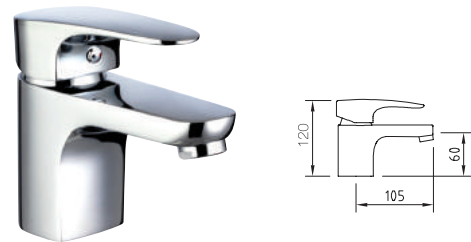
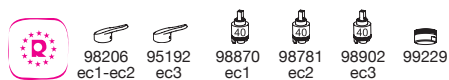

LAVABO 60

Basin mixer 60 | Mitigeur lavabo 60

Mezclador con aireador y flexibles M-10 3/8" x 420 mm.
Mixer, aerator, flexible hoses M-10 3/8" x 420 mm.
Mitigeur lavabo, aérateur, raccords flexibles M-10 3/8" x 420 mm

		Ref.	€	📦
ACS	ec1	99149	81,00	12
	ec2	98914	83,00	12
	ec3	98165	85,00	12
SYNTHETIC	ACS ec1	99150	89,00	12
	ACS ec2	98915	91,00	12
	ACS ec3	98170	93,00	12
METALLIC	ACS ec1	99151	97,00	12
	ACS ec2	98916	99,00	12
	ACS ec3	98171	101,00	12

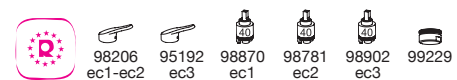



BAÑO-DUCHA
Bath-shower mixer | Mitigeur bain-douche

Mezclador baño-ducha, aireador, inversor automático
Bath-shower mixer, aerator, automatic diverter.
Mitigeur bain-douche, aérateur, inverseur automatique

Incluye teléfono ducha, flexo y soporte
Includes handset, hose and holder
Inclus douchette, flexible et support
(96108, 97670, 98208)

ACS	ec1	98167	117,00	8
-----	-----	-------	--------	---

Sin kit ducha
Without shower kit
Sans kit de douche

ACS	ec1	98280	102,00	8
-----	-----	-------	--------	---



DUCHA
Shower mixer | Mitigeur douche

Mezclador para ducha.
Shower mixer.
Mitigeur douche

Incluye teléfono ducha, flexo y soporte
Includes handset, hose and holder
Inclus douchette, flexible et support
(96108, 97670, 98208)

ACS	ec1	98168	94,00	8
-----	-----	-------	-------	---

Sin kit ducha
Without shower kit
Sans kit de douche

ACS	ec1	98281	79,00	8
-----	-----	-------	-------	---

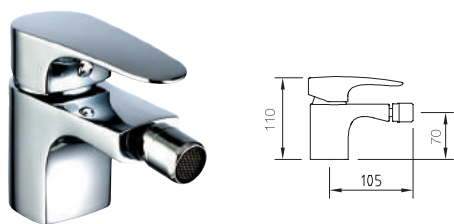

BIDÉ
Bidet mixer | Mitigeur bidet

Mezclador con aireador a rótula y flexibles M-10 3/8" x 370 mm.
Mixer, swivel aerator, flexible hoses M-10 3/8" x 370 mm.
Mitigeur bidet, aérateur rotule, raccords flexibles M-10 3/8" x 370 mm

	Ref.	€	☐
ACS ec2	98166	83,00	12
ACS ec2	98172	91,00	12
ACS ec2	98173	99,00	12



SISTEMA ECONATURE.
Ahorro de agua. Dos posiciones de apertura de la maneta.

Econature system. Save water. Two positions of opening the handle.
Système Econature. Économie d'eau. Deux positions d'ouverture de la poignée.

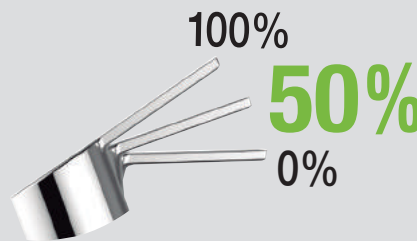

Productos relacionados
Related products
Produits connexes



PAG. 254

xtreme_98655
Accesorios de baño
Bathroom accessories
Accessoires de salle de bain



PAG. 297

HYDRA_98675
Válvula desagüe Universal
Universal drain quick-clac
Vidage Universel



PAG. 296

BIMINI_97106
Válvula de escuadra
Angle valve
Robinet d'equerre



PAG. 49

NINE xtreme_60133
Ducha termostática
Thermostatic shower mixer
Mitigeur douche thermostatique



PAG. 226

CITY AIR_99624
Conjunto ducha
Shower kit
Kit douche

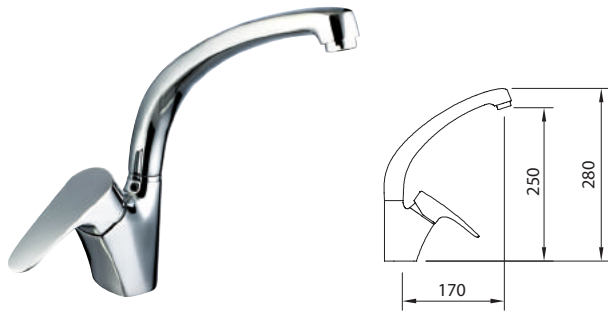

FREGADERO
Sink mixer | Mitigeur évier

Mezclador con aireador, caño conformado giratorio y flexibles M-10 3/8" x 370 mm
Mixer, aerator, swivel tube spout, flexible hoses M-10 3/8" x 370 mm.
Mitigeur évier bec orientable, aérateur, raccords flexibles M-10 3/8" x 370 mm

	Ref.	€	
	98917	123,00	8
	98169	125,00	8

-
-
-
-
-



FREGADERO EXTRAÍBLE
Pull-out sink mixer | Mitigeur évier avec douchette extractible

Mezclador con aireador, caño giratorio, ducha extraíble con pulsador para lavavajillas, enlaces de alimentación flexibles M-10 3/8" x 370 mm.
Mixer with aerator, swivel spout, pull-out handset and flexible hoses M-10 3/8" x 370 mm.
Mitigeur évier bec orientable, douchette extractible, aérateur, raccords flexibles M-10 3/8" x 370 mm

	Ref.	€	
	98552	126,00	12

Incluye Includes Inklus

2 Functions 90794 96117

-
-
-
-

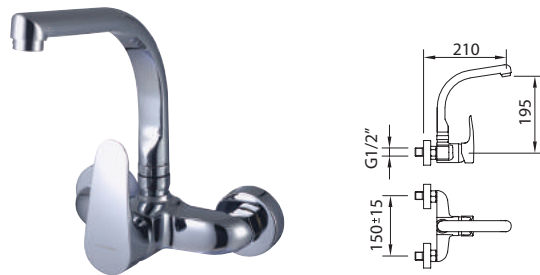

FREGADERO MURAL
Wall mounted single lever sink mixer
Mitigeur évier mural

Mezclador con aireador, caño superior conformado giratorio.
Mixer, aerator, upper swivel tube spout
Mitigeur évier mural, bec orientable façonné, aérateur

	Ref.	€	
	98549	94,00	12

-
-
-



**SISTEMA COLD OPEN
DE APERTURA EN FRÍO.**
AHORRA EN AGUA CALIENTE.

Orientable aerator for greater comfort during its use.
Aérateur orientable pour plus de confort lors de l'utilisation.



SISTEMA ECONATURE
AHORRO DE AGUA.
DOS POSICIONES DE APERTURA
DE LA MANETA.

Econature system. Save water.
Two positions of opening the handle.
Système Econature. Économie d'eau.
Deux positions d'ouverture de la poignée.

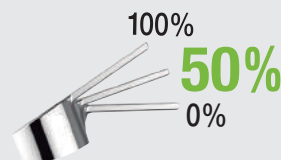





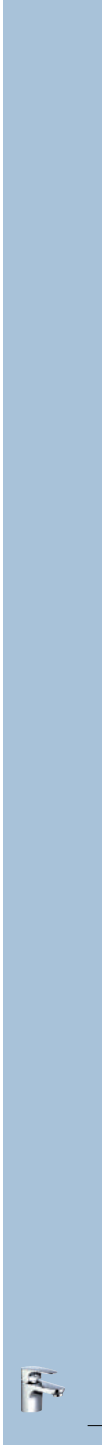

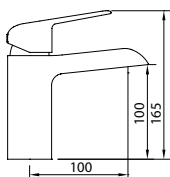



98917
Fregadero
Sink Mixer
Mitiger Évier





LAVABO 100 Tall basin mixer 100 | Mitigeur lavabo 100





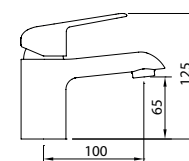



Mezclador con aireador y flexibles M-10 3/8" x 500 mm.
Mixer, aerator, flexible hoses M-10 3/8" x 500 mm.
Mitigeur lavabo, aérateur, raccords flexibles M-10 3/8" x 500 mm

	Ref.	€	📦
  ec1	60173	80,00	8
   ec1	60174	88,00	8
   ec1	60175	96,00	8



LAVABO 65 Basin mixer 65 | Mitigeur lavabo 65

Mezclador con aireador y flexibles M-10 3/8" x 420 mm.
Mixer, aerator, flexible hoses M-10 3/8" x 420 mm.
Mitigeur lavabo, aérateur, raccords flexibles M-10 3/8" x 420 mm

	Ref.	€	📦
  ec1	60170	69,00	12
   ec1	60171	77,00	12
   ec1	60172	85,00	12



Productos relacionados Related products Produits connexes



PAG. 307

PEANA_60559
Base plástica
Plastic base
Base en plastique



PAG. 297

LEO_98674
Válvula desagüe Universal
Universal drain quick-clac
Vidage Universel



PAG. 297

METÁLICO_99127
Desagüe automático
Pop-up
Vidage automatique



PAG. 296

ELEGANCE_96174
Sifón botella latón
Brass bottle trap
Siphon laiton



NEW

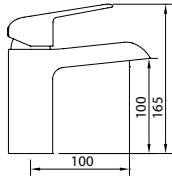

LAVABO 100 BLANCO MATE
Matte white tall basin mixer 100
Mitigeur lavabo blanc mat 100

Mezclador con aireador y flexibles M-10 3/8" x 500 mm.
 Mixer, aerator, flexible hoses M-10 3/8" x 500 mm.
 Mitigeur lavabo, aérateur, raccords flexibles M-10 3/8" x 500 mm

ACS	ec1	Ref.	€	Box	Acabado en blanco. White finish. Finition blanc.
		60712	95,00	12	



NEW

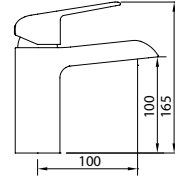

LAVABO 100 NEGRO MATE
Matte black tall basin mixer 100
Mitigeur lavabo noir mat 100

Mezclador con aireador y flexibles M-10 3/8" x 500 mm.
 Mixer, aerator, flexible hoses M-10 3/8" x 500 mm.
 Mitigeur lavabo, aérateur, raccords flexibles M-10 3/8" x 500 mm

ACS	ec1	Ref.	€	Box	Acabado en negro. Black finish. Finition noir.
		60713	95,00	12	

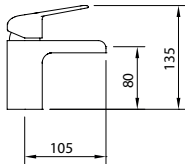

LAVABO CASCADA 80
Basin mixer 80 | Mitigeur lavabo 80

Mezclador, rompeaguas y flexibles M-10 3/8" x 420 mm.
 Mixer, open spout, flexible hoses M-10 3/8" x 420 mm.
 Mitigeur lavabo, brise-jet, raccords flexibles M-10 3/8" x 420 mm

ACS	ec2	Ref.	€	Box
		99931	110,00	8
		99932	118,00	8
		99933	126,00	8

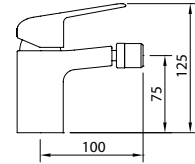

BIDÉ
Bidet mixer | Mitigeur bidet

Mezclador con aireador a rótula y flexibles M-10 3/8" x 420 mm.
 Mixer, swivel aerator, flexible hoses M-10 3/8" x 420 mm.
 Mitigeur bidet, aérateur rotule, raccords flexibles M-10 3/8" x 420 mm

ACS	ec1	Ref.	€	Box
		60176	69,00	12
		60177	77,00	12
		60178	85,00	12



PAG. 252

elegance_99451
 Accesorios de baño
 Bathroom accessories
 Accessoires de salle de bain



PAG. 297

LEO BLANCO MATE_60701
 Válvula desagüe Universal. Metálico
 Universal drain quick-clac. Metallic
 Vidage Universel. Métallique



PAG. 297

LEO NEGRO MATE_60702
 Válvula desagüe Universal. Metálico
 Universal drain quick-clac. Metallic
 Vidage Universel. Métallique



PAG. 226

CITY AIR_99624
 Conjunto ducha
 Shower kit
 Kit douche

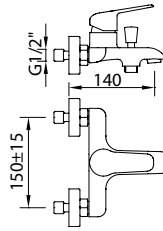

BAÑO-DUCHA
Bath-shower mixer | Mitigeur bain-douche

Mezclador baño-ducha, aireador, inversor automático
Bath-shower mixer, aerator, automatic diverter.
Mitigeur bain-douche, aérateur, inverseur automatique

Incluye teléfono ducha, flexo y soporte
Includes handset, hose and holder
Inclus douchette, flexible et support
(98342, 97670, 60311)

Ref.	€	📦
ACS ec1 60179	120,00	8

Sin kit ducha
Without shower kit
Sans kit de douche

Ref.	€	📦
ACS ec1 60180	105,00	8

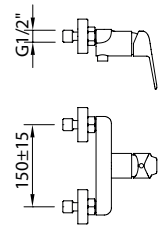

DUCHA
Shower mixer | Mitigeur Douche

Mezclador para ducha.
Shower mixer.
Mitigeur douche

Incluye teléfono ducha, flexo y soporte
Includes handset, hose and holder
Inclus douchette, flexible et support
(98342, 97670, 60311)

Ref.	€	📦
ACS ec1 60181	98,00	8

Sin kit ducha
Without shower kit
Sans kit de douche

Ref.	€	📦
ACS ec1 60182	83,00	8

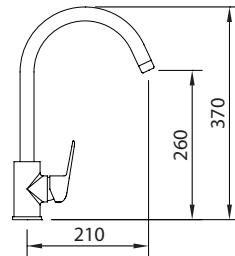

FREGADERO
Sink mixer | Mitigeur évier

Mezclador con aireador, caño conformado giratorio y flexibles M-10 3/8" x 370 mm
Mixer, aerator, swivel tube spout, flexible hoses M-10 3/8" x 370 mm.
Mitigeur évier bec orientable, aérateur, raccords flexibles M-10 3/8" x 370 mm

Ref.	€	📦
ACS ec1 60183	87,00	8

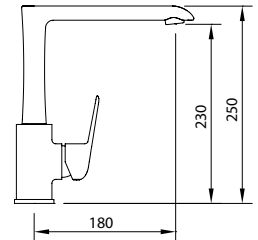

FREGADERO
Sink mixer | Mitigeur évier

Mezclador con aireador, caño fundido giratorio y flexibles M-10 3/8" x 370 mm
Mixer, aerator, swivel spout, flexible hoses M-10 3/8" x 370 mm.
Mitigeur évier bec orientable, aérateur, raccords flexibles M-10 3/8" x 370 mm

Ref.	€	📦
ACS ec1 60184	106,00	8

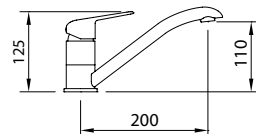

FREGADERO HORIZONTAL
Horizontal sink mixer | Mitigeur évier

Mezclador con aireador, caño giratorio y flexibles M-10 3/8" x 370 mm.
Sink mixer with aerator, swivel spout, flexible hoses M-10 3/8" x 370 mm.
Mitigeur évier bec orientable, aérateur, raccords flexibles M-10 3/8" x 370 mm

Ref.	€	📦
ACS ec1 99386	87,00	12
ACS ec3 99388	91,00	12

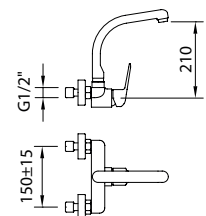

FREGADERO MURAL
Wall mounted single lever sink mixer / Mitigeur évier mural

Mezclador mural con aireador, caño conformado giratorio superior.
Wall mounted mixer with aerator, upper swivel tube spout.
Mitigeur évier mural, bec orientable façonné, aérateur

Ref.	€	📦
ACS ec1 99389	96,00	12



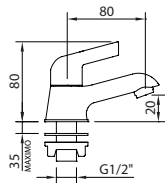

GRIFO SIMPLE REPISA 20
Single handle washbasin tap 20 | Robinet simple 20

Grifo de repisa con aireador.
 Deck mounted single basin tap, with aerator.
 Robinet lavabo, aérateur, 1/2"

	Ref.	€	📦
	99392	34,00	12

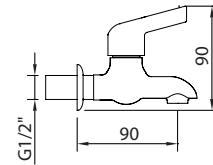

GRIFO SIMPLE MURAL
Single handle washbasin wall tap | Robinet simple mural

Grifo mural con aireador..
 Wall single basin tap, with aerator.
 Robinet lavabo mural, 1/2"

	Ref.	€	📦
	99393	27,00	12

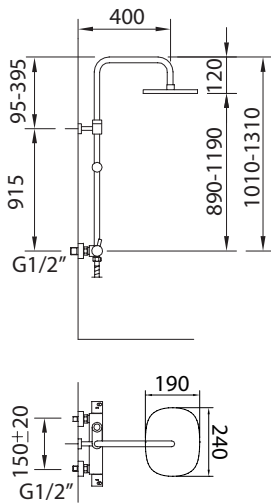
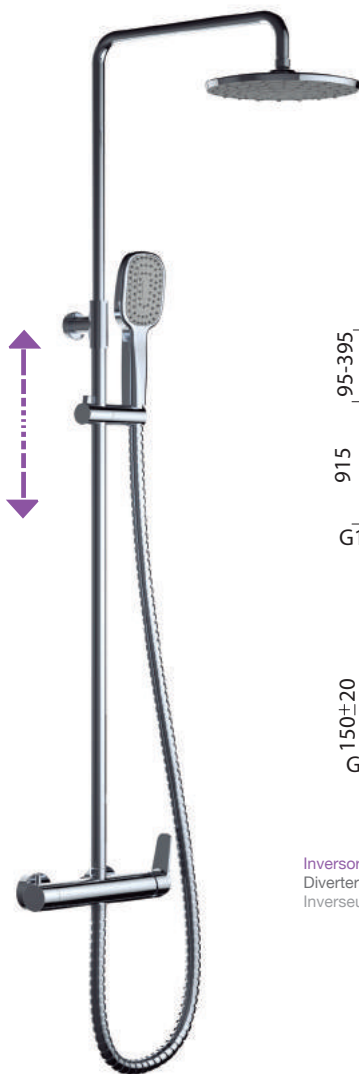

Inversor incorporado en la maneta de caudal
 Diverter built in the flow handle
 Inverseur intégré dans la poignée

CONJUNTO DUCHA EXTENSIBLE
Extensible shower system
Colonne mitigeur bain-douche extensible

Mezclador de ducha con tubo extensible, soporte articulado.
 Adjustable shower system with diverter built in.
 Support douchette coulissant, inverseur intégré, pomme de douche, douchette et flexible

Incluye
 Includes
 Inclus



	Ref.	€	📦
	99646	373,00	-



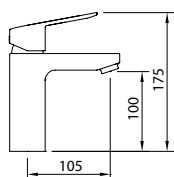

LAVABO 100 Tall basin mixer 100 | Mitigeur lavabo 100

Mezclador con aireador y flexibles M-10 3/8" x 500 mm.
Mixer, aerator, flexible hoses M-10 3/8" x 500 mm.
Mitigeur lavabo, aérateur, raccords flexibles M-10 3/8" x 500 mm

	Ref.	€	📦
ec1	60188	80,00	8
ec1	60189	88,00	8
ec1	60190	96,00	8

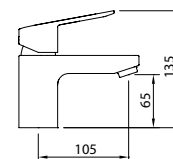
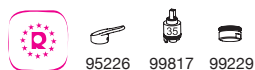

LAVABO 65 Basin mixer 65 | Mitigeur lavabo 65

Mezclador con aireador y flexibles M-10 3/8" x 420 mm.
Mixer, aerator, flexible hoses M-10 3/8" x 420 mm.
Mitigeur Lavabo, aérateur, raccords flexibles M-10 3/8" x 420 mm

	Ref.	€	📦
ec1	60185	69,00	12
ec1	60186	77,00	12
ec1	60187	85,00	12

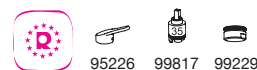

Productos relacionados Related products Produits connexes



PAG. 307

PEANA_60559
Base plástica
Plastic base
Base en plastique



PAG. 297

HYDRA_98675
Válvula desagüe Universal
Universal drain quick-clac
Vidage Universel



PAG. 296

XTREME_96173
Sifón botella latón
Brass bottle trap
Siphon laiton



PAG. 297

METÁLICO_99127
Desagüe automático
Pop-up
Vidage automatique

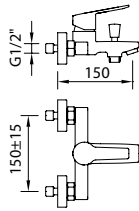

BAÑO-DUCHA
Bath-shower mixer | Mitigeur bain-douche

Mezclador baño-ducha, aireador, inversor automático
Bath-shower mixer, aerator, automatic diverter.
Mitigeur bain-douche, aérateur, inverseur automatique

	Ref.	€	📦
Incluye teléfono ducha, flexo y soporte Includes handset, hose and holder Inclus douchette, flexible et support (98342, 97670, 60311)	ACS ec1 60194	120,00	8
Sin kit ducha Without shower kit Sans kit de douche	ACS ec1 60195	105,00	8

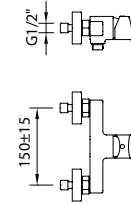

DUCHA
Shower mixer | Mitigeur Douche

Mezclador para ducha.
Shower mixer.
Mitigeur douche

	Ref.	€	📦
Incluye teléfono ducha, flexo y soporte Includes handset, hose and holder Inclus douchette, flexible et support (98342, 97670, 60311)	ACS ec1 60196	98,00	8
Sin kit ducha Without shower kit Sans kit de douche	ACS ec1 60197	83,00	8

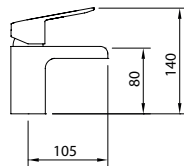

LAVABO CASCADA 80
Basin mixer 80 | Mitigeur lavabo 80

Mezclador, rompeaguas y flexibles M-10 3/8" x 420 mm.
Mixer, open spout, flexible hoses M-10 3/8" x 420 mm.
Mitigeur lavabo, brise-jet, raccords flexibles M-10 3/8" x 420 mm

	Ref.	€	📦
ACS ec2	99928	110,00	8
ACS ec2	99929	118,00	8
ACS ec2	99930	126,00	8

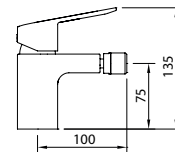

BIDÉ
Bidet mixer | Mitigeur bidet

Mezclador con aireador a rótula y flexibles M-10 3/8" x 420 mm.
Mixer, swivel aerator, flexible hoses M-10 3/8" x 420 mm.
Mitigeur bidet, aérateur rotule, raccords flexibles M-10 3/8" x 420 mm

	Ref.	€	📦
ACS ec1	60191	69,00	12
ACS ec1	60192	77,00	12
ACS ec1	60193	85,00	12



Xtreme_98655
Accesorios de baño
Bathroom accessories
Accessoires de salle de bain

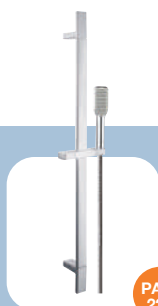

TREND_99626
Conjunto barra ducha
Sliding bar set
Ensemble barre douche



NINE Xtreme_60133
Ducha termostática
Thermostatic shower mixer
Mitigeur douche thermostatique



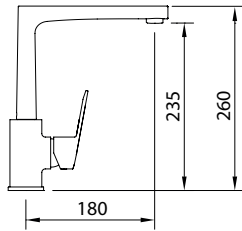

BIMINI_97106
Válvula de escuadra
Angle valve
Robinet d'equerre



FREGADERO

Sink mixer | Mitigeur évier

Mezclador con aireador, caño fundido giratorio, flexibles M-10 3/8" x 370 mm.
 Mixer with aerator, swivel cast spout, flexible hoses M-10 3/8" x 370 mm.
 Mitigeur évier bec orientable, aérateur, raccords flexibles M-10 3/8" x 370 mm

	Ref.	€	
 	60198	100,00	8

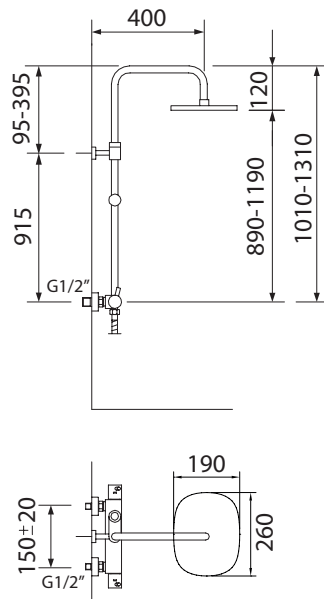



CONJUNTO DUCHA EXTENSIBLE

**Extensible shower system
 Colonne mitigeur bain-douche extensible**

Mezclador de ducha con tubo extensible, soporte articulado.
 Adjustable shower system with diverter built in.
 Support douchette coulissant, inverseur intégré, pomme de douche, douchette et flexible

Incluye
 Includes
 Inclus



	Ref.	€	
  	99727	373,00	-



Inversor incorporado en la maneta de caudal
 Diverter built in the flow handle
 Inverseur intégré dans la poignée

Productos relacionados
 Related products
 Produits connexes



PAG. 236

SILVER HOSE_ 98880
 Flexible. Acabado en plata
 Flexible. Silver finish
 Flexible. Finition argent



PAG. 236

FLEXIBLE_ 97114
 Cromado
 Chrome plated
 Chromé



PAG. 233

STYLE_ 99610
 Teléfono ducha
 Handset
 Douchette



PAG. 224

BEAM_ 60303
 Rociador ø 230mm
 Shower head
 Pomme de douche



99727
Conjunto de ducha extensible
Shower system
Colonne mitigeur douche extensible

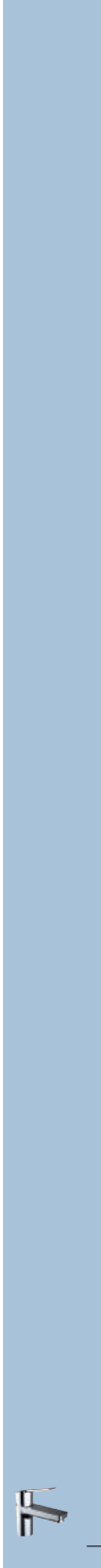

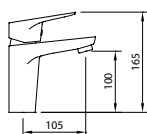

LAVABO 100

Tall basin mixer 100 | Mitigeur lavabo 100

Mezclador con aireador y flexibles M-10 3/8" x 420 mm.
Mixer, aerator, flexible hoses M-10 3/8" x 420 mm.
Mitigeur lavabo, aérateur, raccords flexibles M-10 3/8" x 420 mm

	Ref.	€	12
ACS ec1	99205	80,00	12
ACS ec2	99206	82,00	12
ACS ec3	99207	84,00	12
ACS ec1	99208	88,00	12
ACS ec2	99209	90,00	12
ACS ec3	99210	92,00	12
ACS ec1	99211	96,00	12
ACS ec2	99212	98,00	12
ACS ec3	99213	100,00	12

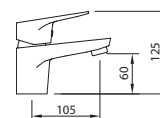
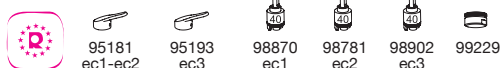

LAVABO 60

Basin mixer 60 | Mitigeur lavabo 60

Mezclador con aireador y flexibles M-10 3/8" x 420 mm.
Mixer, aerator, flexible hoses M-10 3/8" x 420 mm.
Mitigeur lavabo, aérateur, raccords flexibles M-10 3/8" x 420 mm

	Ref.	€	12
ACS NF C1	99153	69,00	12
ACS NF C2	98918	71,00	12
ACS NF C3	99610	73,00	12
ACS NF C1	99154	77,00	12
ACS NF C2	98919	79,00	12
ACS NF C3	98616	81,00	12
ACS NF C1	99155	85,00	12
ACS NF C2	98920	87,00	12
ACS NF C3	98617	89,00	12

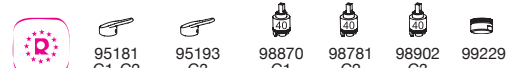

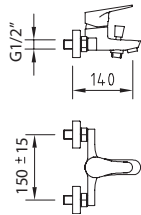

BAÑO-DUCHA
Bath-shower mixer | Mitigeur bain-douche

Mezclador baño-ducha, aireador, inversor automático
Bath-shower mixer, aerator, automatic diverter.
Mitigeur bain-douche, aérateur, inverseur automatique

Incluye teléfono ducha, flexo y soporte
Includes handset, hose and holder
Inclus douchette, flexible et support
(98342, 97670, 98208)

	ec1	98612	120,00	8
--	-----	-------	--------	---

Sin kit ducha
Without shower kit
Sans kit de douche

		C1	98645	105,00	8
--	--	----	-------	--------	---

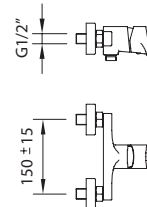

DUCHA
Shower mixer | Mitigeur Douche

Mezclador para ducha.
Shower mixer.
Mitigeur douche

Incluye teléfono ducha, flexo y soporte
Includes handset, hose and holder
Inclus douchette, flexible et support
(98342, 97670, 98208)

	ec1	98613	98,00	8
--	-----	-------	-------	---

Sin kit ducha
Without shower kit
Sans kit de douche

		C1	98646	83,00	8
--	--	----	-------	-------	---

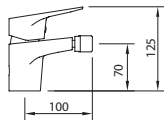

BIDÉ
Bidet mixer | Mitigeur bidet

Mezclador con aireador a rótula y flexibles M-10 3/8" x 420 mm.
Mixer, swivel aerator, flexible hoses M-10 3/8" x 420 mm.
Mitigeur bidet, aérateur rotule, raccords flexibles M-10 3/8" x 420 mm

	Ref.	€	
	ec2	98611	69,00 12
	ec2	98618	77,00 12
	ec2	98619	85,00 12



SISTEMA ECONATURE.
Ahorro de agua. Dos posiciones de apertura de la maneta.

Econature system. Save water. Two positions of opening the handle.

Système Econature. Économie d'eau. Deux positions d'ouverture de la poignée.

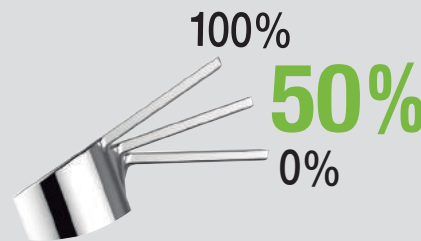

Productos relacionados
Related products
Produits connexes



PAG. 256

Urban_99459
Accesorios de baño
Bathroom accessories
Accessoires de salle de bain



PAG. 297

LEO_98674
Válvula desagüe Universal
Universal drain quick-clac
Vidage Universel



PAG. 296

DESIGN_40010
Válvula escuadra
Angle Valve
Robinet d'équerre



PAG. 141

NINE Urban_60325
Ducha termostática
Thermostatic shower mixer
Mitigeur douche thermostatique



PAG. 226

CITY AIR_99624
Conjunto ducha
Shower kit
Kit douche



FREGADERO
Sink mixer | Mitigeur évier

Mezclador con aireador, caño conformado giratorio, flexibles M-10 3/8" x 420 mm.
Mixer with aerator, swivel tube spout, flexible hoses M-10 3/8" x 420 mm.
Mitigeur évier bec orientable, aérateur, raccords flexibles M-10 3/8" x 420 mm

		Ref.	€	📦
		98921	88,00	12
		98615	92,00	12

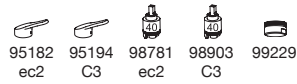

FREGADERO
Sink mixer | Mitigeur évier

Mezclador con aireador, caño fundido giratorio, flexibles M-10 3/8" x 420 mm.
Mixer with aerator, swivel cast spout, flexible hoses M-10 3/8" x 420 mm.
Mitigeur évier bec orientable, aérateur, raccords flexibles M-10 3/8" x 420 mm

		Ref.	€	📦
		98922	100,00	12
		98614	102,00	12

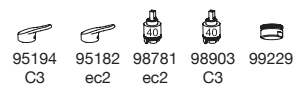



98615
Fregadero
Sink Mixer
Mitiger Évier

F

PANAM EVO · ELEGANCE · NEW COLLECTION · PANAM EVO
PANAM EVO · ELEGANCE · NEW COLLECTION · PANAM EVO
PANAM EVO · ELEGANCE · NEW COLLECTION · PANAM EVO
PANAM EVO · ELEGANCE · NEW COLLECTION · PANAM EVO
PANAM EVO · ELEGANCE · NEW COLLECTION · PANAM EVO
PANAM EVO · ELEGANCE · NEW COLLECTION · PANAM EVO
PANAM EVO · ELEGANCE · NEW COLLECTION · PANAM EVO
PANAM EVO · ELEGANCE · NEW COLLECTION · PANAM EVO
PANAM EVO · ELEGANCE · NEW COLLECTION · PANAM EVO
PANAM EVO · ELEGANCE · NEW COLLECTION · PANAM EVO
PANAM EVO · ELEGANCE · NEW COLLECTION · PANAM EVO

RENOVAMOS EL DISEÑO SIN PERDER LA ESENCIA

WE RENEW THE DESIGN WITHOUT LOSING ITS ESSENCE
NOUS RÉNOVONS LE DESIGN, SANS PERDRE L'ESSENCE



The EVOLution

PANAM EVO

elegance

new · collection





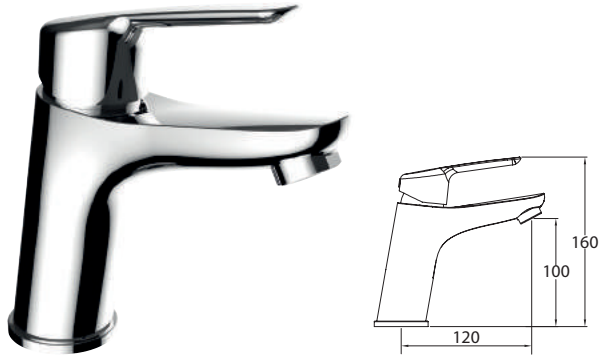

NEW

STYLES PRO



LAVABO 100
Basin mixer 100 | Mitigeur lavabo 100





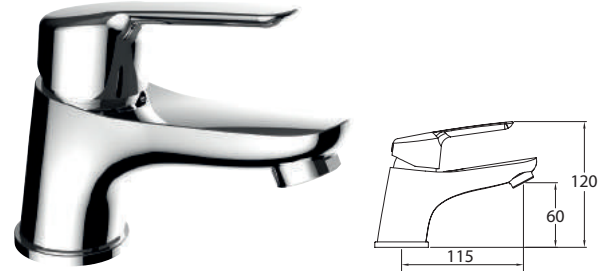

Mezclador con aireador y flexibles M-10 3/8" x 500 mm.
Mixer, aerator, flexible hoses M-10 3/8" x 500 mm.
Mitigeur lavabo, aérateur, raccords flexibles M-10 3/8" x 500 mm

	Ref.	€	
 	ec1 60538	63,00	-
 	ec1 60539	71,00	-
 	ec1 60540	79,00	-



LAVABO 60
Basin mixer 60 | Mitigeur lavabo 60

Mezclador con aireador y flexibles M-10 3/8" x 420 mm.
Mixer, aerator, flexible hoses M-10 3/8" x 420 mm.
Mitigeur bidet, aérateur, raccords flexibles M-10 3/8" x 420 mm

	Ref.	€	
 	ec1 60535	53,00	-
 	ec1 60536	61,00	-
 	ec1 60537	69,00	-



PANAM



PANAM EVO



ESPECIFICACIONES TÉCNICAS TECHNICALS ESPECIFICATIONS		
110 mm	ALTURA HEIGHT	120 mm
45 mm	DISTANCIA CONFORT COMFORT DISTANCE	60 mm
<input checked="" type="checkbox"/>	PEANA BASIS	<input checked="" type="checkbox"/> 4 mm
Ø40	CARTUCHO CARTRIDGE	Ø35
ABS FRONTAL	INDICE INDEX	SILICONA POSTERIOR
<input checked="" type="checkbox"/>	FRIO-CALIENTE MANETA BLUE-RED MARK HANDLE	<input checked="" type="checkbox"/>
ABS 0°	PORTACADENILLAS CHAIN HOLDER	ABS 25°
CLASE B 12-16 L/min	AIREADOR AERATOR	CLASE A 9-12 L/min



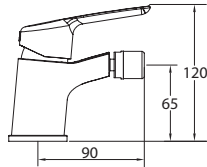









BIDÉ

Bidet mixer | Mélangeur bidet

Mezclador con aireador a rótula y flexibles M-10 3/8" x 420 mm.
Mixer, swivel aerator, flexible hoses M-10 3/8" x 420 mm.
Mitigeur bidet, aérateur rotule, raccords flexibles M-10 3/8" x 420 mm

	Ref.	€	
  ec1	60541	53,00	-
   ec1	60542	61,00	-
   ec1	60543	69,00	-

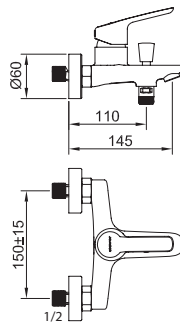

BAÑO-DUCHA

Bath-shower mixer | Mitigeur bain-douche

Mezclador baño-ducha, aireador, inversor automático
Bath-shower mixer, aerator, automatic diverter.
Mitigeur bain-douche, aérateur, inverseur

	Ref.	€	
Incluye teléfono ducha, flexo y soporte Includes handset, hose and holder Inclus douchette, flexible et support (98342, 97670, 98343)	  ec1	60544	85,00 -
Sin kit ducha Without shower kit Sans kit de douche	 ec1	60545	75,00 -



DURACIÓN MECÁNICA

*Mechanic Duration
Durabilité mécanique*



Ensayar la duración mecánica de las partes móviles mediante ciclos enteros en **cartuchos, caños e inversores**.

Test the duration of the mechanical moving parts by cycles on the cartridges, spouts and diverters.

Test d'endurance mécanique des éléments mobiles, cartouches, becs et inverseurs.



Cartucho/ Cartridge / Cartouche

70.000

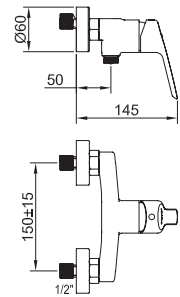

DUCHA

Shower mixer | Mitigeur Douche

Mezclador para ducha.
Shower mixer.
Mitigeur douche

	Ref.	€	
Incluye teléfono ducha, flexo y soporte Includes handset, hose and holder Inclus douchette, flexible et support (98342, 97670, 98343)	  ec1	60546	70,00 -
Sin kit ducha Without shower kit Sans kit de douche	 ec1	60547	60,00 -



Productos relacionados
Related products
Produits connexes



PAG. 141

NINE urban_ 60325
Ducha termostática
Thermostatic shower mixer
Mitigeur douche thermostatique



PAG. 296

DESIGN_ 40010
Válvula de escuadra
Angle valve
Robinet d'equerre



PAG. 236

FLEXIBLE_ 97114
Flexible
Flexible
Flexible



PAG. 226

CITY AIR_ 99624
Conjunto barra ducha
Sliding bar set
Ensemble barre de douche

NEW

STYLES PRO



FREGADERO
Sink mixer | Mitigeur évier

Mezclador con aireador, caño conformado giratorio, flexibles M-10 3/8" x 370 mm.
Mixer with aerator, swivel tube spout, flexible hoses M-10 3/8" x 370 mm.
Mitigeur évier bec orientable, aérateur, raccords flexibles M-10 3/8" x 370 mm



	Ref.	€	
 	60548	75,00	-

-  95253
-  99817
-  99229



FREGADERO
Sink mixer | Mitigeur évier

Mezclador con aireador, caño fundido giratorio y enlaces de alimentación flexibles M-10 3/8" x 370 mm.
Mixer with aerator, swivel cast spout and connections M10-3/8" x 370 mm.
Mitigeur évier bec orientable, aérateur, raccords flexibles M-10 3/8" x 370 mm



	Ref.	€	
 	60594	81,00	-

-  95253
-  99817
-  99229



FREGADERO MURAL
Wall mounted single lever sink mixer
Mitigeur évier mural

Mezclador mural con aireador, caño conformado giratorio superior.
Wall mounted mixer with aerator, upper swivel tube spout.
Mitigeur évier mural, bec orientable façonné, aérateur

	Ref.	€	
 	60549	91,00	-

-  95253
-  99817
-  99229



PANAM EVO · ELEGANCE · NEW COLLECTION · PANAM EVO
PANAM EVO · ELEGANCE · NEW COLLECTION · PANAM EVO
PANAM EVO · ELEGANCE · NEW COLLECTION · PANAM EVO
PANAM EVO · ELEGANCE · NEW COLLECTION · PANAM EVO
PANAM EVO · ELEGANCE · NEW COLLECTION · PANAM EVO
PANAM EVO · ELEGANCE · NEW COLLECTION · PANAM EVO
PANAM EVO · ELEGANCE · NEW COLLECTION · PANAM EVO
PANAM EVO · ELEGANCE · NEW COLLECTION · PANAM EVO

**RENOVAMOS
EL DISEÑO
SIN PERDER
LA ESENCIA**

WE RENEW THE DESIGN WITHOUT LOSING ITS ESSENCE
NOUS RÉNOVONS LE DESIGN, SANS PERDRE L'ESSENCE



The EVOLution

PANAM EVO

xtreme

new · collection

NEW

STYLES PRO

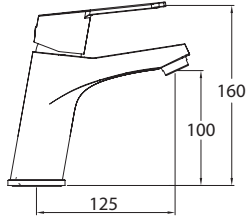

LAVABO 100

Basin mixer 100 | Mitigeur lavabo 100



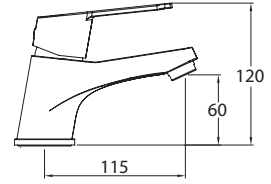



Mezclador con aireador y flexibles M-10 3/8" x 500 mm.
Mixer with aerator, flexible hoses M-10 3/8" x 500 mm.
Mitigeur lavabo, aérateur, raccords flexibles M-10 3/8" x 500 mm









LAVABO 60

Basin mixer 60 | Mitigeur lavabo 60

Mezclador con aireador y flexibles M-10 3/8" x 420 mm.
Mixer with aerator, flexible hoses M-10 3/8" x 420 mm.
Mitigeur lavabo, aérateur, raccords flexibles M-10 3/8" x 420 mm

	Ref.	€	☐
 	ec1 60523	63,00	12
 	ec1 60524	71,00	12
 	ec1 60525	79,00	12



	Ref.	€	☐
 	ec1 60520	53,00	12
 	ec1 60521	61,00	12
 	ec1 60522	69,00	12





PANAM



PANAM EVO



ESPECIFICACIONES TÉCNICAS TECHNICALS ESPECIFICATIONS		
110 	ALtura HIGHT	120 
50 	DISTANCIA CONFORT COMFORT DISTANCE	60 
	PEANA BASIS	 4 
Ø40	CARTUCHO CARTRIDGE	Ø35
ABS FRONTAL	INDICE INDEX	SILICONA POSTERIOR
	FRIO-CALIENTE MANETA BLUE-RED MARK HANDLE	
ABS 0°	PORTACADENILLAS CHAIN HOLDER	ABS 25°
CLASE B 12-16 L/min	AIREADOR AERATOR	CLASE A 9-12 L/min



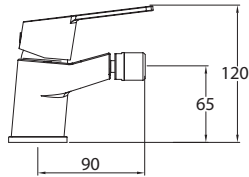

BIDÉ
Bidet mixer | Mitigeur bidet

Mezclador con aireador a rótula y flexibles M-10 3/8" x 420 mm.
Mixer, swivel aerator, flexible hoses M-10 3/8" x 420 mm.
Mitigeur bidet, aérateur rotule, raccords flexibles M-10 3/8" x 420 mm

	Ref.	€	📦
	ec1 60526	53,00	12
	ec1 60527	61,00	12
	ec1 60528	69,00	12

- 95254
- 99817
- 99232



BAÑO-DUCHA
Bath-shower mixer | Mitigeur bain-douche

Mezclador baño-ducha, aireador, inversor automático
Bath-shower mixer, aerator, automatic diverter.
Mitigeur bain-douche, aérateur, inverseur

	Ref.	€	📦
Incluye teléfono ducha, flexo y soporte Includes handset, hose and holder Inclus douchette, flexible et support (98342, 97670, 98343)	ec1 60529	85,00	-
Sin kit ducha Without shower kit Sans kit de douche	ec1 60530	75,00	-

- 95254
- 60620
- 96200
- 98490

DURACIÓN MECÁNICA
Mechanic Duration
Durabilité mécanique



Ensayar la duración mecánica de las partes móviles mediante ciclos enteros en **cartuchos, caños e inversores**.

Test the duration of the mechanical moving parts by cycles on the cartridges, spouts and diverters.

Test d'endurance mécanique des éléments mobiles, cartouches, becs et inverseurs.



Cartucho/ Cartridge / Cartouche

70.000

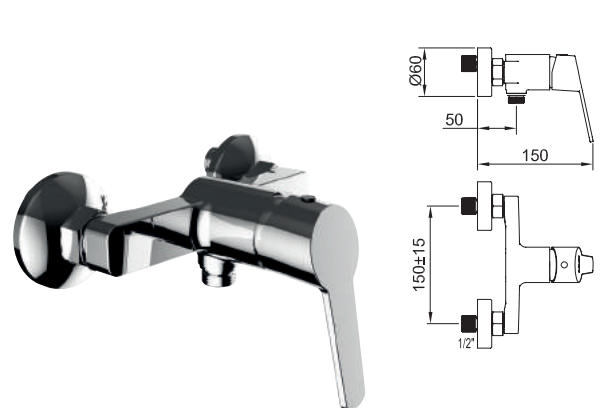

DUCHA
Shower mixer | Mitigeur Douche

Mezclador para ducha.
Shower mixer.
Mitigeur douche

	Ref.	€	📦
Incluye teléfono ducha, flexo y soporte Includes handset, hose and holder Inclus douchette, flexible et support (98342, 97670, 98343)	ec1 60531	70,00	-
Sin kit ducha Without shower kit Sans kit de douche	ec1 60532	60,00	-

- 95254
- 99817

Productos relacionados
Related products
Produits connexes



urban_99459
Accesorios de baño
Bathroom accessories
Accessoires de salle de bain



LEO_98674
Válvula desagüe Universal. Metálico
Universal drain quick-clac. Metallic
Vidage Universel. Métallique



xtreme_96173
Sifón botella latón
Brass bottle trap
Siphon laiton



SINTÉTICO_99130
Desagüe automático
Pop-up
Vidage automatique

NEW

STYLES PRO

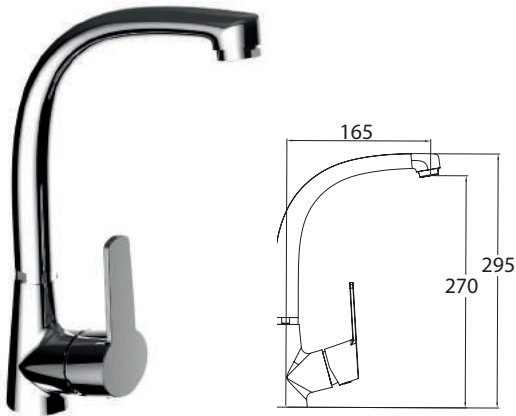

FREGADERO
Sink mixer | Mitigeur évier

Mezclador con aireador, caño conformado giratorio, flexibles M-10 3/8" x 370 mm.
Mixer with aerator, swivel tube spout, flexible hoses M-10 3/8" x 370 mm.
Mitigeur évier bec orientable, aérateur, raccords flexibles M-10 3/8" x 370 mm

	Ref.	€	
  ec1	60533	75,00	-

-  95255
-  99817
-  99229



FREGADERO MURAL
*Wall mounted single lever sink mixer
Mitigeur évier mural*

Mezclador mural con aireador, caño conformado giratorio superior.
Wall mounted mixer with aerator, upper swivel tube spout.
Mitigeur évier mural, bec orientable façonné, aérateur

	Ref.	€	
  ec1	60534	91,00	-

-  95255
-  99817
-  99229



PAG. 236

FLEXIBLE_97114
Flexible
Flexible
Flexible



PAG. 296

DESIGN_40010
Válvula de escuadra
Angle valve
Robinet d'equerre

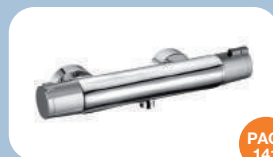

PAG. 141

NINE_urban_60325
Ducha termostática
Thermostatic shower mixer
Mitigeur douche thermostatique



PAG. 226

TREND_99626
Conjunto barra ducha
Sliding bar set
Ensemble barre douche

PANAM EVO · ELEGANCE · NEW COLLECTION · PANAM EVO
PANAM EVO · ELEGANCE · NEW COLLECTION · PANAM EVO
PANAM EVO · ELEGANCE · NEW COLLECTION · PANAM EVO
PANAM EVO · ELEGANCE · NEW COLLECTION · PANAM EVO
PANAM EVO · ELEGANCE · NEW COLLECTION · PANAM EVO
PANAM EVO · ELEGANCE · NEW COLLECTION · PANAM EVO
PANAM EVO · ELEGANCE · NEW COLLECTION · PANAM EVO

RENOVAMOS EL DISEÑO SIN PERDER LA ESENCIA

WE RENEW THE DESIGN WITHOUT LOSING ITS ESSENCE
NOUS RÉNOVONS LE DESIGN, SANS PERDRE L'ESSENCE



The EVOLution

PANAM EVO

urban
new · collection

NEW

STYLES PRO

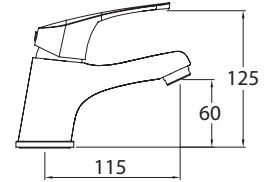
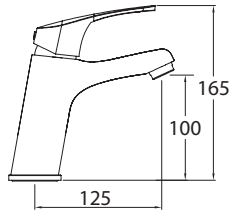

LAVABO 100

Basin mixer 100 | Mitigeur lavabo 100

Mezclador con aireador y flexibles M-10 3/8" x 500 mm.
Mixer with aerator, flexible hoses M-10 3/8" x 500 mm.
Mitigeur lavabo, aérateur, raccords flexibles M-10 3/8" x 500 mm

	Ref.	€	📦
	60503	63,00	12
	60504	71,00	12
	60505	79,00	12



LAVABO 65

Basin mixer 65 | Mitigeur lavabo 65

Mezclador con aireador y flexibles M-10 3/8" x 420 mm.
Mixer with aerator, flexible hoses M-10 3/8" x 420 mm.
Mitigeur lavabo, aérateur, raccords flexibles M-10 3/8" x 420 mm

	Ref.	€	📦
	60500	53,00	12
	60501	61,00	12
	60502	69,00	12



PANAM



PANAM EVO



ESPECIFICACIONES TÉCNICAS TECHNICALS ESPECIFICATIONS		
120 mm	ALTURA HEIGHT	125 mm
60 mm	DISTANCIA CONFORT COMFORT DISTANCE	60 mm
	PEANA BASIS	4 mm
ø40	CARTUCHO CARTRIDGE	ø35
ABS FRONTAL	INDICE INDEX	SILICONA POSTERIOR
	FRIO-CALIENTE MANETA BLUE-RED MARK HANDLE	
ABS 0°	PORTACADENILLAS CHAIN HOLDER	ABS 25°
CLASE B 12-16 L/min	AIREADOR AERATOR	CLASE A 9-12 L/min



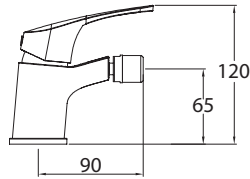







BIDÉ

Bidet mixer | Mitigeur bidet

Mezclador con aireador a rótula y flexibles M-10 3/8" x 420 mm.
 Mixer, swivel aerator, flexible hoses M-10 3/8" x 420 mm.
 Mitigeur bidet, aérateur rotule, raccords flexibles M-10 3/8" x 420 mm

	Ref.	€	📦
 	ec1 60506	53,00	12
 	ec1 60507	61,00	12
 	ec1 60508	69,00	12

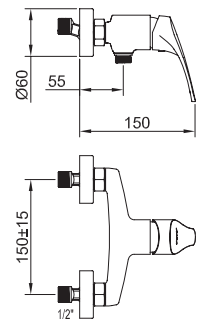
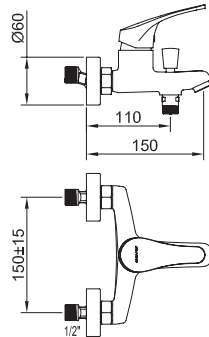

BAÑO-DUCHA

Bath-shower mixer | Mitigeur bain-douche

Mezclador baño-ducha, aireador, inversor automático
 Bath-shower mixer, aerator, automatic diverter.
 Mitigeur bain-douche, aérateur, inverseur

	Ref.	€	📦
Incluye teléfono ducha, flexo y soporte Includes handset, hose and holder Inclus douchette, flexible et support (98342, 97670, 98343)	 	ec1 60509	85,00 -
Sin kit ducha Without shower kit Sans kit de douche		ec1 60510	75,00 -



DUCHA

Shower mixer | Mitigeur Douche

Mezclador para ducha.
 Shower mixer.
 Mitigeur douche

	Ref.	€	📦
Incluye teléfono ducha, flexo y soporte Includes handset, hose and holder Inclus douchette, flexible et support (98342, 97670, 98343)	 	ec1 60511	70,00 -
Sin kit ducha Without shower kit Sans kit de douche		ec1 60512	60,00 -



Productos relacionados
 Related products
 Produits connexes



PAG. 256

urban_99459
 Accesorios de baño
 Bathroom accessories
 Accessoires de salle de bain



PAG. 297

LEO_98674
 Válvula desagüe Universal. Metálico
 Universal drain quick-clac. Metallic
 Vidage Universel. Métallique



PAG. 296

ELEGANCE_96174
 Sifón botella latón
 Brass bottle trap
 Siphon laiton



PAG. 297

SINTÉTICO_99130
 Desagüe automático
 Pop-up
 Vidage automatique

NEW

STYLES PRO

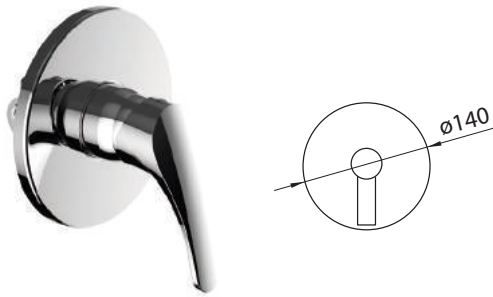

DUCHA EMPOTRAR 1 VÍA

Wall mounted shower mixer 1 outlet diverter | Mitigeur à encastrer / 1 voie

Mezclador empotrable de 1/2" para ducha
Concealed shower mixer 1/2"
Mitigeur encastré, 1/2"

	Ref.	€	
	ec1 60518	75,00	-

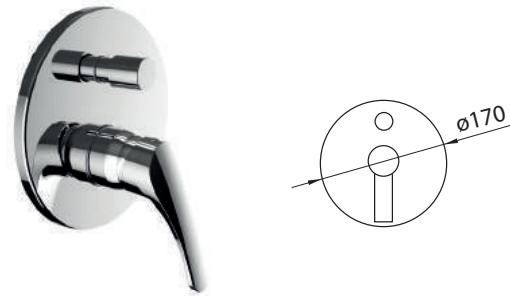

BAÑO DUCHA EMPOTRAR 2 VÍAS

Wall mounted bath-shower mixer 2 outlet diverter | Mitigeur à encastrer / 2 voies

Mezclador empotrable de 1/2" para baño-ducha, inversor automático
Concealed bath-shower mixer 1/2", automatic diverter
Mitigeur encastré, 1/2", inverseur automatique

	Ref.	€	
	ec1 60519	116,00	-

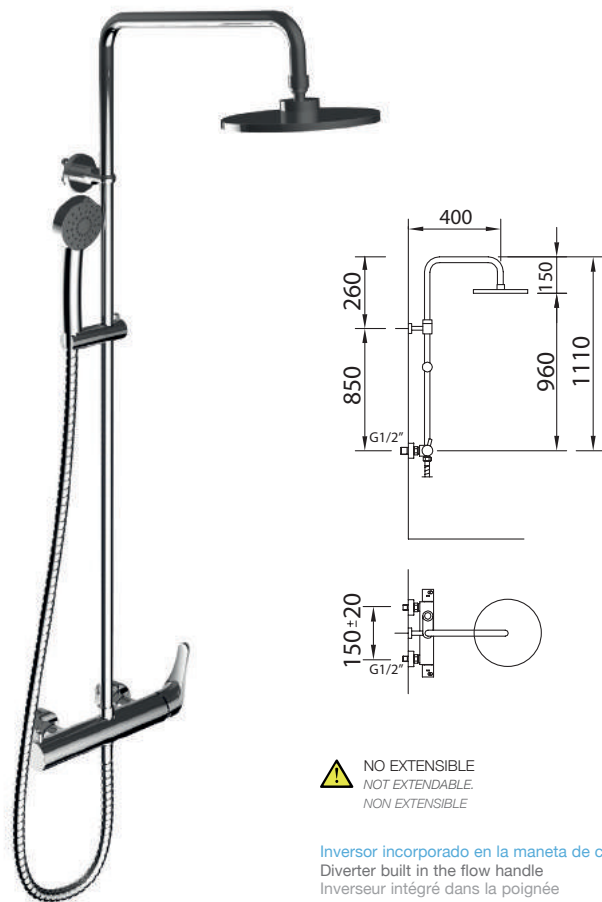

**⚠ NO EXTENSIBLE
NOT EXTENDABLE
NON EXTENSIBLE**

**Inversor incorporado en la maneta de caudal
Diverter built in the flow handle
Inverseur intégré dans la poignée**

CONJUNTO DUCHA

**Shower system
Colonne mitigeur douche**

Mezclador de ducha, soporte articulado deslizable.
Adjustable shower valve with automatic diverter.
Ensemble de douche, pomme de douche supérieure articulée,
douchette et flexible

**Incluye
Includes
Inclus**



	Ref.	€	
	60517	320,00	-



ATLAS_97800
Ducha higiénica
Shattaf
Douche hygiénique

PAG. 270



DESIGN_40010
Válvula de escuadra
Angle valve
Robinet d'equerre

PAG. 296



NINE Urban_60325
Ducha termostática
Thermostatic shower mixer
Mitigeur douche thermostatique

PAG. 141



CITY AIR_99624
Conjunto barra ducha
Sliding bar set
Ensemble barre de douche

PAG. 226

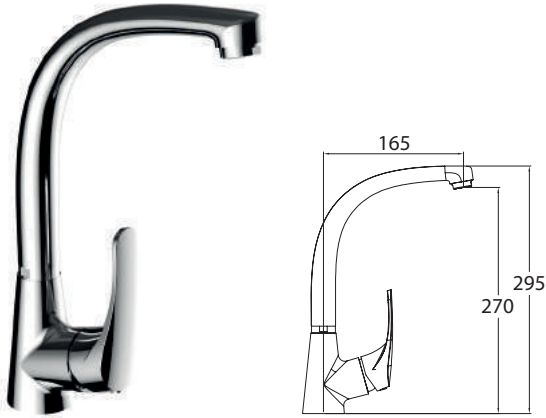

FREGADERO
Sink mixer | Mitigeur évier

Mezclador con aireador, caño conformado giratorio, flexibles M-10 3/8" x 370 mm.
Mixer with aerator, swivel tube spout, flexible hoses M-10 3/8" x 370 mm.
Mitigeur évier bec orientable, aérateur, raccords flexibles M-10 3/8" x 370 mm

	Ref.	€	
	60513	75,00	-

95257 99817 99229

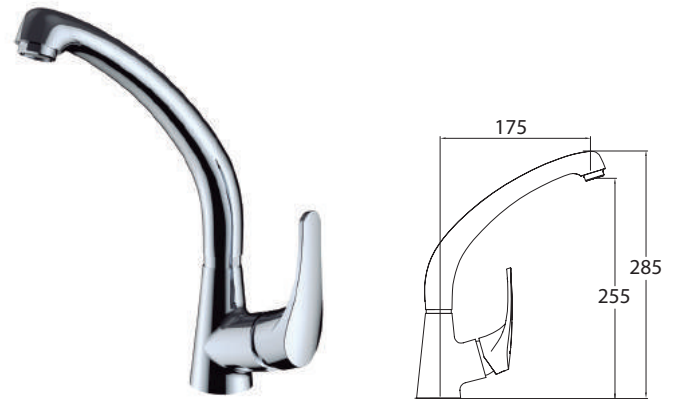

FREGADERO
Sink mixer | Mitigeur évier

Mezclador con aireador, caño fundido giratorio y enlaces de alimentación flexibles M-10 3/8" x 370 mm.
Mixer with aerator, swivel cast spout and connections M10-3/8" x 370 mm.
Mitigeur évier bec orientable, aérateur, raccords flexibles M-10 3/8" x 370 mm

	Ref.	€	
	60592	81,00	-

95257 99817 99229

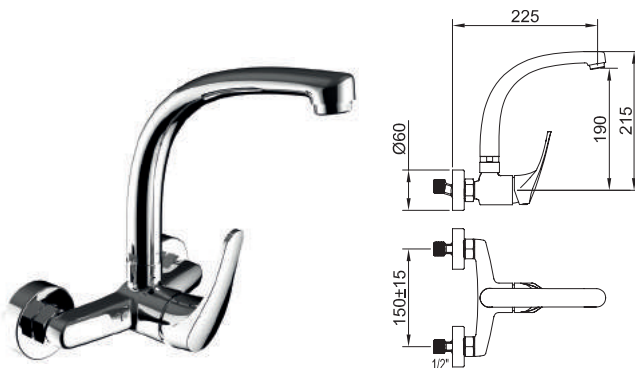

FREGADERO MURAL
Wall mounted single lever sink mixer
Mitigeur évier mural

Mezclador mural con aireador, caño conformado giratorio superior.
Wall mounted mixer with aerator, upper swivel tube spout.
Mitigeur évier mural, bec orientable façonné, aérateur

	Ref.	€	
	60514	91,00	-

95257 99817 99230

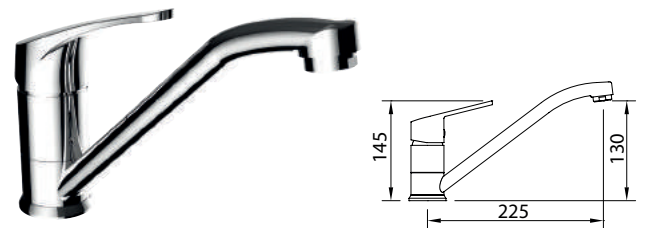

FREGADERO HORIZONTAL
Horizontal sink mixer | Mitigeur évier

Mezclador con aireador, caño giratorio y flexibles M-10 3/8" x 370 mm.
Sink mixer with aerator, swivel spout and flexible hoses M10-3/8" x 370 mm.
Mitigeur évier bec orientable, aérateur, raccords flexibles M-10 3/8" x 370 mm

	Ref.	€	
	60516	67,00	-

95256 99226 90025



60513
Fregadero
Sink Mixer
Mitiger Évier



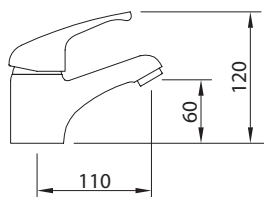

LAVABO 60

Basin mixer 60 | Mitigeur lavabo 60

Mezclador alto con aireador y flexibles M-10 3/8" x 370 mm.
Mixer with aerator, flexible hoses M-10 3/8" x 370 mm.
Mitigeur lavabo, aérateur, raccords flexibles M-10 3/8" x 370 mm

	Ref.	€	📦
ec1	94695	53,00	12
ec1	96541	61,00	12
ec1	97935	69,00	12

95012 90760 90025

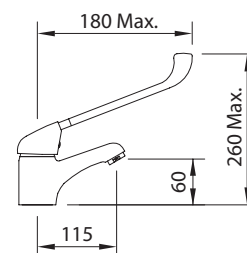

GRIFERÍA CON MANETA GERONTOLÓGICA

Sink mixer with medical lever | Mitigeur lavabo avec manette médicale

Mezclador con aireador, con palanca gerontológica y flexibles M-10 3/8" x 370 mm.
Mixer with medical lever operated with aerator, flexible hoses M-10 3/8" x 370 mm.
Mitigeur lavabo, manette médicale, aérateur, raccords flexibles M-10 3/8" x 370 mm

	Ref.	€	📦
	94694	61,00	12

96256 90760 90025

Productos relacionados
Related products
Produits connexes



PAG. 257

Urban_99459
Accesorios de baño
Bathroom accessories
Accessoires de salle de bain



PAG. 297

LEO_98674
Válvula desagüe Universal. Metálico
Universal drain quick-clac. Metallic
Vidage Universel. Métallique



PAG. 296

ELEGANCE_96174
Sifón botella latón
Brass bottle trap
Siphon laiton



PAG. 297

SINTÉTICO_99130
Desagüe automático
Pop-up
Vidage automatique



BAÑO-DUCHA
Bath-shower mixer | Mitigeur bain-douche

Mezclador baño-ducha, aireador, inversor automático
Bath-shower mixer, aerator, automatic diverter.
Mitigeur bain-douche, aérateur, inverseur

	Ref.	€	📦
Incluye teléfono ducha, flexo y soporte Includes handset, hose and holder Inclus douchette, flexible et support (98342, 97670, 90011)	ACS ec1 94697	85,00	8
Sin kit ducha Without shower kit Sans kit de douche	ACS ec1 98817	75,00	8



DUCHA
Shower mixer | Mitigeur Douche

Mezclador para ducha.
Shower mixer.
Mitigeur douche

	Ref.	€	📦
Incluye teléfono ducha, flexo y soporte Includes handset, hose and holder Inclus douchette, flexible et support (98342, 97670, 90011)	ACS ec1 94698	70,00	8
Sin kit ducha Without shower kit Sans kit de douche	ACS ec1 98818	60,00	8

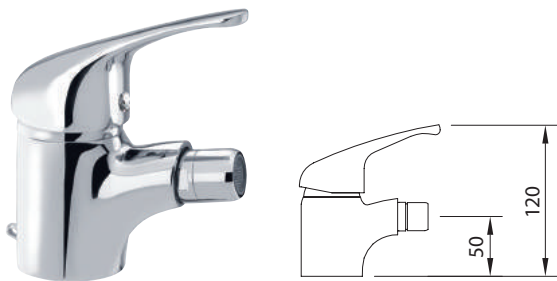

BIDÉ
Bidet mixer | Mitigeur bidet

Mezclador con aireador a rótula y flexibles M-10 3/8" x 370 mm.
Mixer, swivel aerator, flexible hoses M-10 3/8" x 370 mm.
Mitigeur bidet, aérateur rotule, raccords flexibles M-10 3/8" x 370 mm

	Ref.	€	📦
ACS ec1 94696	53,00	12	
SYNTHETIC ACS ec1 96542	61,00	12	
METALLIC ACS ec1 97936	69,00	12	

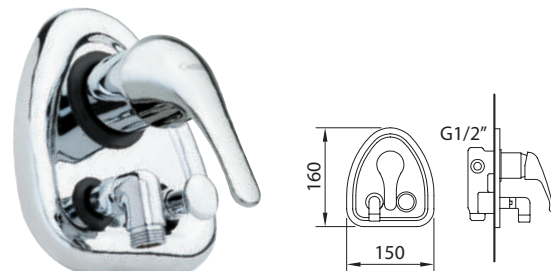

BAÑO DUCHA EMPOTRAR 2 VÍAS
Wall mounted shower mixer with diverter 2 outlet
diverter | Mitigeur à encastrer / 2 voies

Mezclador empotrable de 1/2" para ducha con codo giratorio.
Concealed mixer 1/2" for shower with swivel elbow.
Mitigeur encastré, 1/2", inverseur automatique

	Ref.	€	📦
Incluye teléfono ducha, flexo y soporte Includes handset, hose and holder Inclus douchette, flexible et support (96108, 97670, 90011)	ec1 96066	118,00	8



NINE Urban_ 97676
Ducha termostática
Thermostatic shower mixer
Mitigeur douche thermostatique



ATLAS_ 97800
Ducha higiénica
Shattaf
Douche hygiénique



DESIGN_ 40010
Válvula de escuadra
Angle valve
Robinet d'equerre



FLEXIBLE_ 97114
Flexible
Flexible
Flexible

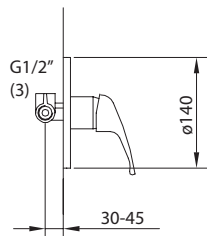

DUCHA EMPOTRAR 1 VÍA

Wall mounted shower mixer 1 outlet diverter | Mitigeur à encastrer / 1 voie

Mezclador empotrable de 1/2" para ducha
Concealed shower mixer 1/2"
Mitigeur encastré, 1/2"

Ref.	€	📦
ec1 98455	75,00	12



95012 90761

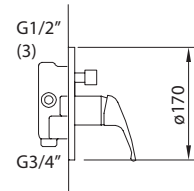

BAÑO DUCHA EMPOTRAR 2 VÍAS

Wall mounted bath-shower mixer 2 outlet diverter | Mitigeur à encastrer / 2 voies

Mezclador empotrable de 1/2" para baño-ducha, inversor automático
Concealed bath-shower mixer 1/2", automatic diverter
Mitigeur encastré, 1/2", inverseur automatique

Ref.	€	📦
ec1 98456	116,00	12



95012 90761

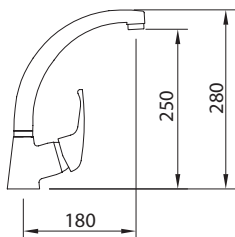

FREGADERO

Sink mixer | Mitigeur évier

Mezclador con aireador, caño conformado giratorio y flexibles M-10 3/8" x 370 mm
Mixer, aerator, swivel tube spout, flexible hoses M-10 3/8" x 370 mm.
Mitigeur évier bec orientable, aérateur, raccords flexibles M-10 3/8" x 370 mm

Ref.	€	📦
ACS ec1 92350	75,00	12



95110 90760 90025

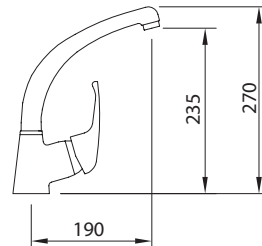

FREGADERO

Sink mixer | Mitigeur évier

Mezclador con aireador, caño fundido giratorio, flexibles M-10 3/8" x 370 mm.
Mixer with aerator, swivel cast spout, flexible hoses M-10 3/8" x 370 mm.
Mitigeur évier bec orientable, aérateur, raccords flexibles M-10 3/8" x 370 mm

Ref.	€	📦
ACS ec1 92351	81,00	12



95110 90760 99229



PAG. 212

iclever 2_ 98711 + 98724
Ducha empotrada 1 vía
Concealed bath-shower 1 outlet diverter
Douche encastré 1 voie



PAG. 214

iclever 2_ 98711 + 98739
Ducha empotrada 2 vías
Concealed bath-shower 2 outlet diverter
Douche encastré 2 voies



PAG. 223

ROUND AIR_ 99604 + LUZIA_96153
Rociador y brazo
Shower head and arm
Pomme de douche et bras



PAG. 237

CAIMAN urban_ 98236
Salida flexo mural con soporte
Wall hose bib outlet with holder
Sortie flexible murale avec suport

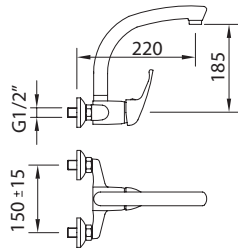

FREGADERO MURAL
Wall mounted single lever sink mixer
Mitigeur évier mural

Mezclador con aireador, caño conformado giratorio.
 Mixer with aerator, swivel tube spout.
 Mitigeur évier mural, bec orientable façonné, aérateur

Ref.	€	📦
ACS ec1 96067	91,00	12

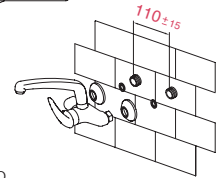
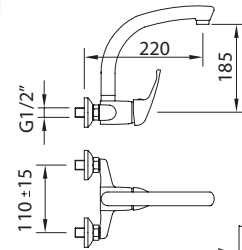

FREGADERO MURAL 110
Wall mounted single lever sink mixer
Mitigeur évier mural

Mezclador con aireador, caño conformado giratorio.
 Mixer with aerator, swivel tube spout.
 Mitigeur évier mural, bec orientable façonné, aérateur

Ref.	€	📦
ACS ec1 98500	91,00	12

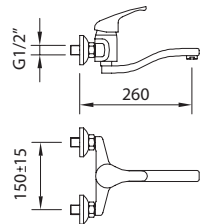

FREGADERO MURAL
Wall mounted sink mixer | Mitigeur évier mural

Mezclador mural con aireador y caño giratorio inferior.
 Wall mounted mixer operated with aerator, flower swivel spout
 Mitigeur évier mural, bec orientable façonné, aérateur

Ref.	€	📦
ACS ec1 97805	87,00	8

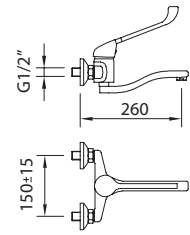

FREGADERO CON MANETA GERONTOLÓGICA
Wall mounted sink mixer with medical lever | Mitigeur évier mural, manette médicale

Mezclador mural con aireador, con palanca gerontológica y caño giratorio inferior.
 Wall mounted mixer with medical lever operated with aerator, flower swivel spout
 Mitigeur évier mural, manette médicale, bec orientable façonné, aérateur

Ref.	€	📦
ACS ec1 97975	95,00	12

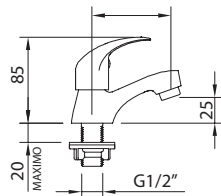

GRIFO SIMPLE REPISA
Single handle washbasin tap | Robinet simple

Grifo de repisa con aireador.
 Deck mounted single basin tap, with aerator.
 Robinet lavabo, aérateur, 1/2"

Ref.	€	📦
ACS 98458	27,00	48

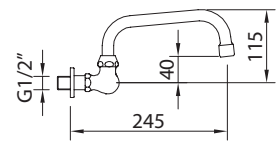

GRIFO SIMPLE MURAL
Wall mounted single tap | Robinet simple mural

Grifo de pared con aireador y caño conformado giratorio.
 Deck mounted single faucet aerator and swivel tube spout.
 Robinet évier bec orientable, aérateur.

Ref.	€	📦
ACS 98459	32,00	12



S12 elegance

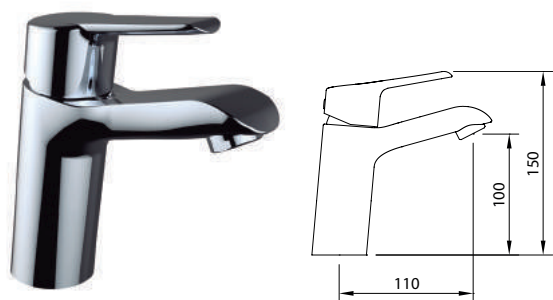

LAVABO 100

Tall basin mixer 100 | Mitigeur lavabo 100

Mezclador con aireador y flexibles M-10 3/8" x 420 mm.
Mixer, aerator, flexible hoses M-10 3/8" x 420 mm.
Mitigeur lavabo, aérateur, raccords flexibles M-10 3/8" x 420 mm

		Ref.	€	12
SYNTHETIC	ACS ec1	99838	63,00	12
	ACS ec2	99320	65,00	12
	ACS ec3	99326	67,00	12
SYNTHETIC	ACS ec1	99839	71,00	12
	ACS ec2	99321	73,00	12
	ACS ec3	99327	75,00	12
METALLIC	ACS ec1	99840	79,00	12
	ACS ec2	99322	81,00	12
	ACS ec3	99328	83,00	12

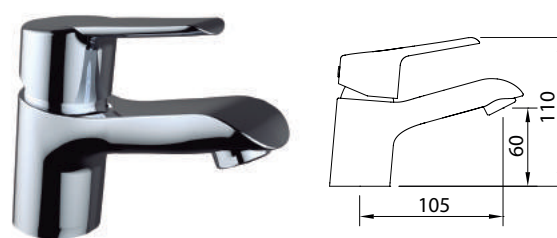

LAVABO 60

Basin mixer 60 | Mitigeur lavabo 60

Mezclador con aireador y flexibles M-10 3/8" x 370 mm.
Mixer, aerator, flexible hoses M-10 3/8" x 370 mm.
Mitigeur Lavabo, aérateur, raccords flexibles M-10 3/8" x 370 mm

		Ref.	€	12
SYNTHETIC	ACS ec1	99835	53,00	12
	ACS ec2	99317	55,00	12
	ACS ec3	99323	57,00	12
SYNTHETIC	ACS ec1	99836	61,00	12
	ACS ec2	99318	63,00	12
	ACS ec3	99324	65,00	12
METALLIC	ACS ec1	99837	69,00	12
	ACS ec2	99319	71,00	12
	ACS ec3	99325	73,00	12

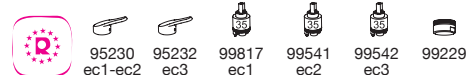

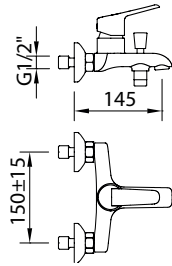

BAÑO-DUCHA
Bath-shower mixer | Mitigeur bain-douche

Mezclador baño-ducha, aireador, inversor automático
Bath-shower mixer, aerator, automatic diverter.
Mitigeur bain-douche, aérateur, inverseur

Incluye teléfono ducha, flexo y soporte
Includes handset, hose and holder
Inclus douchette, flexible et support
(98342, 97670, 98343)

	Ref.	€	
	99844	85,00	6+6
	99845	75,00	6+6

Sin kit ducha
Without shower kit
Sans kit de douche

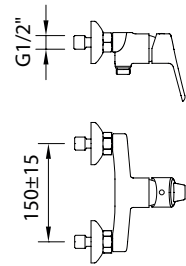

DUCHA
Shower mixer | Mitigeur Douche

Mezclador para ducha.
Shower mixer.
Mitigeur douche

Incluye teléfono ducha, flexo y soporte
Includes handset, hose and holder
Inclus douchette, flexible et support
(98342, 97670, 98343)

	Ref.	€	
	99846	70,00	6+6
	99847	60,00	6+6

Sin kit ducha
Without shower kit
Sans kit de douche

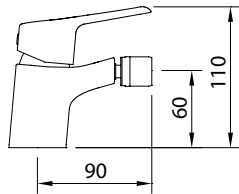

BIDÉ
Bidet mixer | Mitigeur bidet

Mezclador con aireador a rótula y flexibles M-10 3/8" x 370 mm.
Mixer, swivel aerator, flexible hoses M-10 3/8" x 370 mm.
Mitigeur bidet, aérateur rotule, raccords flexibles M-10 3/8" x 370 mm

	Ref.	€	
	99841	53,00	12
	99842	61,00	12
	99843	69,00	12



SISTEMA ECONATURE.
Ahorro de agua. Dos posiciones de apertura de la maneta.

Econature system. Save water. Two positions of opening the handle.
Système Econature. Économie d'eau. Deux positions d'ouverture de la poignée.

100%
50%
0%

Productos relacionados
Related products
Produits connexes



PEANA_60559
Base plástica
Plastic base
Base en plastique



LEO_60558
Válvula desague Universal
Universal drain quick-clac
Vidage Universel



elegance_99451
Accesorios de baño
Bathroom accessories
Accessoires de salle de bain



DESIGN_40010
Válvula de escuadra
Angle valve
Robinet d'equerre

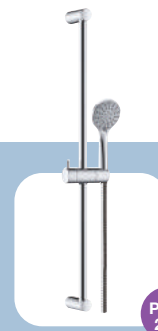

CITY AIR_99624
Conjunto barra ducha
Sliding bar set
Ensemble barre de douche

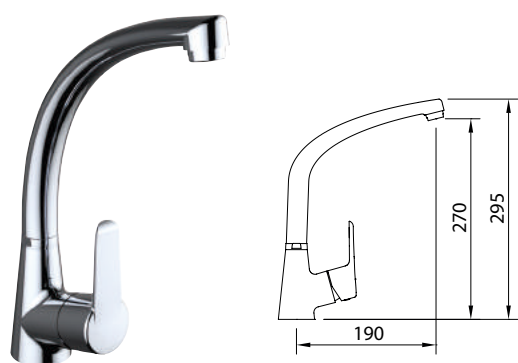

FREGADERO
Sink mixer | Mitigeur évier

Mezclador con aireador, caño conformado giratorio, flexibles M-10 3/8" x 370 mm.
Mixer with aerator, swivel tube spout, flexible hoses M-10 3/8" x 370 mm.
Mitigeur évier bec orientable, aérateur, raccords flexibles M-10 3/8" x 370 mm

	Ref.	€	
	99848	75,00	12
	99340	79,00	12

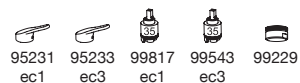

FREGADERO MURAL
Wall mounted single lever sink mixer | Mitigeur évier mural

Mezclador mural con aireador, caño conformado giratorio superior.
Wall mounted mixer with aerator, upper swivel tube spout.
Mitigeur évier mural, bec orientable façonné, aérateur

	Ref.	€	
	99849	91,00	12

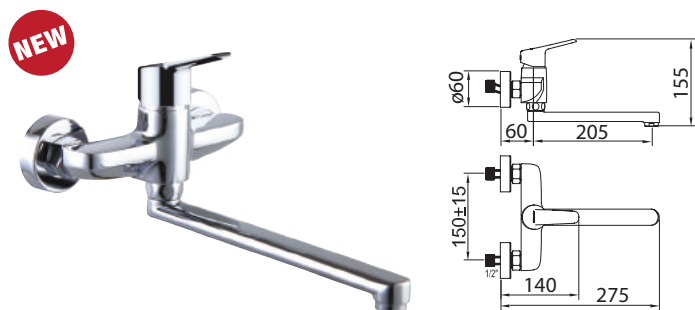

FREGADERO MURAL
Wall mounted sink mixer | Mitigeur évier mural

Mezclador mural con aireador, caño giratorio inferior.
Wall mounted mixer operated with aerator, flower swivel spout.
Mitigeur évier mural, bec orientable façonné, aérateur

	Ref.	€	
	60726	87,00	-





99848
Fregadero
Sink mixer
Mitigeur évier



S12 xtreme

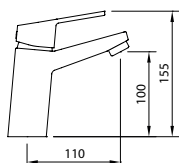

LAVABO 100

Tall basin mixer 100 | Mitigeur lavabo 100

Mezclador con aireador y flexibles M-10 3/8" x 420 mm.
Mixer, aerator, flexible hoses M-10 3/8" x 420 mm.
Mitigeur lavabo, aérateur, raccords flexibles M-10 3/8" x 420 mm

		Ref.	€	☐
	ec1	99823	63,00	12
	ec2	99245	65,00	12
	ec3	99251	67,00	12
	ec1	99824	71,00	12
	ec2	99246	73,00	12
	ec3	99252	75,00	12
	ec1	99825	79,00	12
	ec2	99247	81,00	12
	ec3	99253	83,00	12

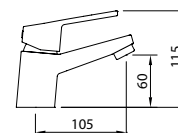
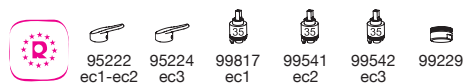

LAVABO 60

Basin mixer 60 | Mitigeur lavabo 60

Mezclador alto con aireador y flexibles M-10 3/8" x 370 mm.
Mixer with aerator, flexible hoses M-10 3/8" x 370 mm.
Mitigeur lavabo, aérateur, raccords flexibles M-10 3/8" x 370 mm

		Ref.	€	☐
	ec1	99820	53,00	12
	ec2	99242	55,00	12
	ec3	99248	57,00	12
	ec1	99821	61,00	12
	ec2	99243	63,00	12
	ec3	99249	65,00	12
	ec1	99822	69,00	12
	ec2	99244	71,00	12
	ec3	99250	73,00	12

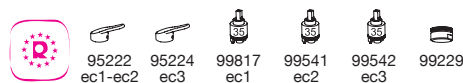



BAÑO-DUCHA
Bath-shower mixer | Mitigeur bain-douche

Mezclador baño-ducha, aireador, inversor automático
Bath-shower mixer, aerator, automatic diverter.
Mitigeur bain-douche, aérateur, inverseur

Incluye teléfono ducha, flexo y soporte
Includes handset, hose and holder
Inclus douchette, flexible et support
(98342, 97670, 98343)

	Ref.	€	
	99829	85,00	6+6

Sin kit ducha
Without shower kit
Sans kit de douche

	99830	75,00	6+6
--	-------	-------	-----



DUCHA
Shower mixer | Mitigeur Douche

Mezclador para ducha.
Shower mixer.
Mitigeur douche

Incluye teléfono ducha, flexo y soporte
Includes handset, hose and holder
Inclus douchette, flexible et support
(98342, 97670, 98343)

	Ref.	€	
	99831	70,00	6+6

Sin kit ducha
Without shower kit
Sans le kit de douche

	99832	60,00	6+6
--	-------	-------	-----

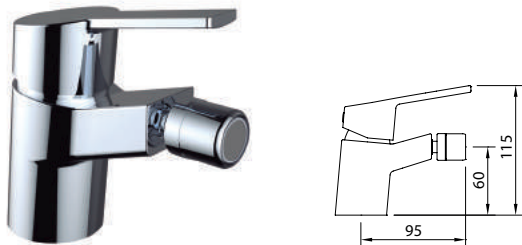

BIDÉ
Bidet mixer | Mitigeur bidet

Mezclador con aireador a rótula y flexibles M-10 3/8" x 370 mm.
Mixer, swivel aerator, flexible hoses M-10 3/8" x 370 mm.
Mitigeur bidet, aérateur rotule, raccords flexibles M-10 3/8" x 370 mm

	Ref.	€	
	99826	53,00	12
	99827	61,00	12
	99828	69,00	12



SISTEMA COLD OPEN DE APERTURA EN FRÍO. AHORRA EN AGUA CALIENTE.

Cold Open system. It opens in cold position. You save energy.
Cold Open. Système d'ouverture en eau froide pour faire des économies d'énergie.



Productos relacionados
Related products
Produits connexes



PEANA_60559
Base plástica
Plastic base
Base en plastique

PAG. 307



LEO_60558
Válvula desagüe Universal
Universal drain quick-clac
Vidage Universel

PAG. 297



Xtreme_98655
Accesorios de baño
Bathroom accessories
Accessoires de salle de bain

PAG. 254



BIMINI_97106
Válvula de escuadra
Angle valve
Robinet d'equerre

PAG. 296



TREND_99626
Conjunto barra ducha
Sliding bar set
Ensemble barre douche

PAG. 226

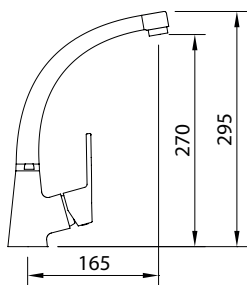

FREGADERO

Sink mixer | Mitigeur évier

Mezclador con aireador, caño conformado giratorio, flexibles M-10 3/8" x 370 mm.

Mixer with aerator, swivel tube spout, flexible hoses M-10 3/8" x 370 mm.

Mitigeur évier bec orientable, aérateur, raccords flexibles M-10 3/8" x 370 mm

	Ref.	€	📦
	99833	75,00	12
	99265	79,00	12

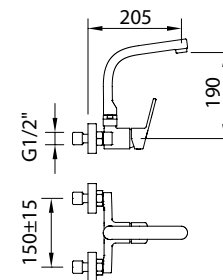
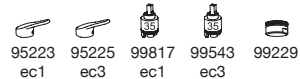

FREGADERO MURAL

Wall mounted single lever sink mixer | Mitigeur évier mural

Mezclador mural con aireador, caño conformado giratorio superior.

Wall mounted sink mixer with aerator, upper swivel tube spout.

Mitigeur évier mural, bec orientable façonné, aérateur

	Ref.	€	📦
	99834	91,00	12



NEW

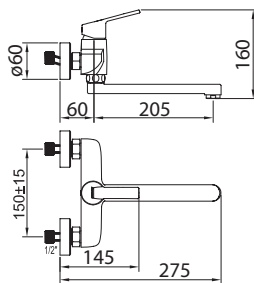

FREGADERO MURAL

Wall mounted sink mixer | Mitigeur évier mural

Mezclador mural con aireador, caño giratorio inferior.

Wall mounted mixer operated with aerator, flower swivel spout.

Mitigeur évier mural, bec orientable façonné, aérateur

	Ref.	€	📦
	60727	87,00	-





99833
Fregadero
Sink mixer
Mitigeur évier



S12 urban





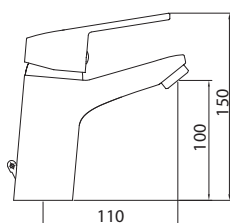



NEW



LAVABO 100
Basin mixer 100 | Mitigeur lavabo 100

Mezclador con aireador y flexibles M-10 3/8" x 420 mm.
Basin mixer with aerator, flexible hoses M-10 3/8" x 420 mm.
Mitigeur lavabo, aérateur, raccords flexibles M-10 3/8" x 420 mm

	Ref.	€	📦
  ec1	60716	63,00	12
  ec1	60717	71,00	12
  ec1	60718	79,00	12





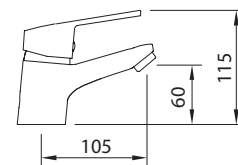























96174 98237 90025



LAVABO 60
Basin mixer 60 | Mitigeur lavabo 60

Mezclador con aireador y flexibles M-10 3/8" x 370 mm.
Basin mixer with aerator, flexible hoses M-10 3/8" x 370 mm.
Mitigeur lavabo, aérateur, raccords flexibles M-10 3/8" x 370 mm

	Ref.	€	📦
  ec1	98330	53,00	12
  C2 	99161	57,00	12
  C3  	98800	59,00	12
  ec1	98336	61,00	12
  C2 	99162	65,00	12
  C3  	98805	67,00	12
  ec1	98337	69,00	12
  C2 	99163	73,00	12
  C3  	98806	75,00	12



96174 95195 98237 98781 98902 90025 99229
ec1-C2 C3 ec1 C2 C3 ec1 C2-C3



BAÑO-DUCHA
Bath-shower mixer | Mitigeur bain-douche

Mezclador baño-ducha, aireador, inversor automático
 Bath-shower mixer, aerator, automatic diverter.
 Mitigeur bain-douche, aérateur, inverseur

	Ref.	€	📦
Incluye teléfono ducha, flexo y soporte Includes handset, hose and holder Inclus douchette, flexible et support (98342, 97670, 98343)	ACS ec1 98332	85,00	8
Sin kit ducha Without shower kit Sans kit de douche	ACS ec1 98340	75,00	8



DUCHA
Shower mixer | Mitigeur Douche

Mezclador para ducha.
 Shower mixer.
 Mitigeur douche

	Ref.	€	📦
Incluye teléfono ducha, flexo y soporte Includes handset, hose and holder Inclus douchette, flexible et support (98342, 97670, 98343)	ACS ec1 98333	70,00	8
Sin kit ducha Without shower kit Sans kit de douche	ACS ec1 98341	60,00	8

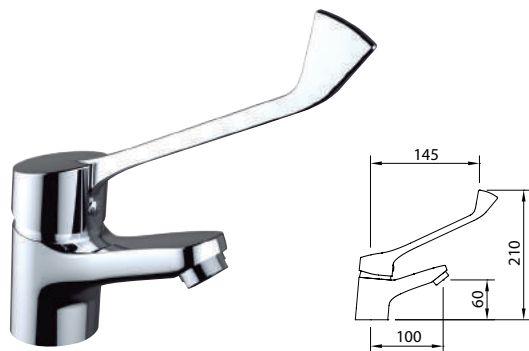

LAVABO 60 CON MANETA GERONTOLÓGICA
Basin mixer 60 with medical lever
Mitigeur lavabo 60 avec manette médicale

Mezclador con aireador, con palanca gerontológica y flexibles M-10 3/8" x 370 mm.
 Mixer with medical lever operated with aerator, flexible hoses M-10 3/8" x 370 mm.
 Mitigeur lavabo, manette médicale, aérateur, raccords flexibles M-10 3/8" x 370 mm

	Ref.	€	📦
ACS	99214	61,00	12

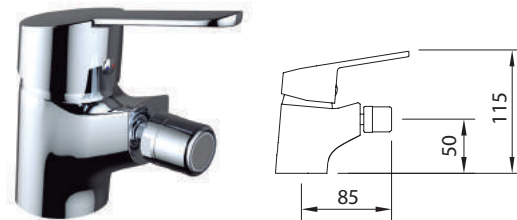
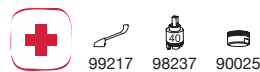

BIDÉ
Bidet mixer | Mitigeur bidet

Mezclador con aireador a rótula y flexibles M-10 3/8" x 370 mm.
 Mixer, swivel aerator, flexible hoses M-10 3/8" x 370 mm.
 Mitigeur bidet, aérateur rotule, raccords flexibles M-10 3/8" x 370 mm

	Ref.	€	📦
ACS ec1 98331	53,00	12	
SYNTHETIC ACS ec1 98338	61,00	12	
METALLIC ACS ec1 98339	69,00	12	



Productos relacionados
 Related products
 Produits connexes



urban_99459
 Accesorios de baño
 Bathroom accessories
 Accessoires de salle de bain

PAG. 257



LEO_60558
 Válvula desague Universal
 Universal drain quick-clac
 Vidage Universel

PAG. 297



NINE SLIM urban_60414
 Ducha termostática
 Thermostatic shower mixer
 Mitigeur douche thermostatique

PAG. 140



Iclever 2_98711+98725
 Ducha empotrada 1 via
 Concealed bath-shower 1 outlet diverter
 Douche encastré 1 voie

PAG. 212



CITY AIR_99624
 Conjunto ducha
 Shower kit
 Kit douche

PAG. 226



FREGADERO
Sink mixer | Mitigeur évier

Mezclador con aireador, caño conformado giratorio, flexibles M-10 3/8" x 370 mm.
Mixer with aerator, swivel tube spout, flexible hoses M-10 3/8" x 370 mm.
Mitigeur évier bec orientable, aérateur, raccords flexibles M-10 3/8" x 370 mm

	Ref.	€	
	98334	75,00	12
	98803	79,00	12

95175	95196	98237	98903	99229
ec1	C3	ec1	C3	



FREGADERO
Sink mixer | Mitigeur évier

Mezclador con aireador, caño fundido giratorio y enlaces de alimentación flexibles M-10 3/8" x 370 mm.
Mixer with aerator, swivel cast spout and connections M10-3/8" x 370 mm.
Mitigeur évier bec orientable, aérateur, raccords flexibles M-10 3/8" x 370 mm

	Ref.	€	
	98344	81,00	12
	98804	85,00	12

95175	95196	98237	98903	99229
ec1	C3	ec1	C3	



FREGADERO HORIZONTAL
Horizontal sink mixer | Mitigeur évier

Mezclador con aireador, caño giratorio y flexibles M-10 3/8" x 370 mm.
Sink mixer, aerator, swivel spout, flexible hoses M-10 3/8" x 370 mm.
Mitigeur évier bec orientable, aérateur, raccords flexibles M-10 3/8" x 370 mm

	Ref.	€	
	99221	67,00	12
	99222	69,00	12
	99223	71,00	12

99224	99225	99226	99227	99228	90025
ec1-ec2	ec3	ec1	ec2	ec3	



FREGADERO MURAL CAÑO LARGO
Long spout wall mounted sink mixer
Mitigeur évier mural

Mezclador mural con aireador, caño conformado giratorio superior.
Wall mounted sink mixer with aerator, upper swivel tube spout.
Mitigeur évier mural, bec orientable façonné, aérateur

	Ref.	€	
	98329	94,00	12

95175	98237	90025

NEW



FREGADERO MURAL
Wall mounted sink mixer | Mitigeur évier mural

Mezclador mural con aireador, caño giratorio inferior.
 Wall mounted mixer operated with aerator, lower swivel spout.
 Mitigeur évier mural, bec orientable façonné, aérateur

	Ref.	€	
	ec1 60725	87,00	-



FREGADERO MURAL
Wall mounted sink mixer | Mitigeur évier mural

Mezclador mural con aireador, caño conformado giratorio superior.
 Wall mounted sink mixer with aerator, upper swivel tube spout.
 Mitigeur évier mural, bec orientable façonné, aérateur

	Ref.	€	
	ec1 98335	91,00	12

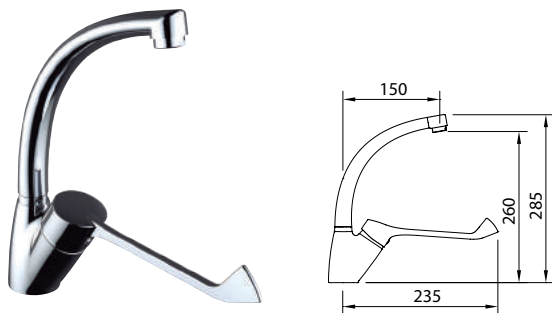

FREGADERO CON MANETA GERONTOLÓGICA
Sink mixer with medical lever | Mitigeur évier avec manette médicale

Fregadero con maneta gerontológica con aireador y caño conformado giratorio y flexibles M-10 3/8" x 370 mm con palanca gerontológica.
 Sink mixer with medical lever with mixer, swivel tube spout, with medical lever operated with aerator, flexible hoses M-10 3/8" x 370 mm.
 Mitigeur évier, manette médicale, bec orientable façonné, aérateur, raccords flexibles M-10 3/8" x 370 mm

	Ref.	€	
	99215	85,00	8

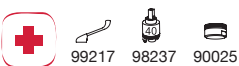

FREGADERO MURAL CON MANETA GERONTOLÓGICA
Wall sink mixer with medical lever | Mitigeur évier mural avec manette médicale

Fregadero con maneta gerontológica mural con aireador, caño giratorio inferior.
 Sink mixer with medical lever with mixer, with wall mounted mixer, medical lever operated with aerator, lower swivel spout.
 Mitigeur évier mural, manette médicale, bec orientable façonné, aérateur

	Ref.	€	
	99216	99,00	12



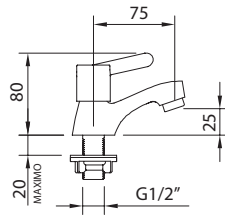

GRIFERÍA SIMPLE REPISA
Single handle washin tap / Robinet simple

Grifo de repisa, con aireador.
Deck mounted single faucet, with aerator.
Robinet lavabo, aérateur, 1/2"

Ref.	€	📦
98449	27,00	48

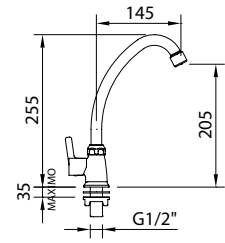

GRIFO SIMPLE REPISA
Single mixer | Robinet simple

Con caño conformado giratorio con aireador.
Swivel tube spout, aerator.
Robinet lavabo, aérateur, 1/2"

Ref.	€	📦
98992	32,00	24

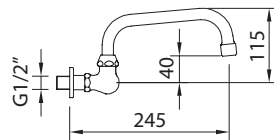

GRIFO SIMPLE MURAL
Wall mounted single mixer | Robinet simple mural

Grifo simple mural con aireador y caño conformado giratorio.
Wall mounted single tap aerator and swivel tube spout.
Robinet évier bec orientable, aérateur

Ref.	€	📦
98450	32,00	12

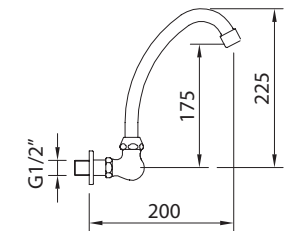

GRIFO SIMPLE MURAL
Wall mounted single mixer | Robinet simple mural

Grifo simple mural con aireador y caño conformado giratorio.
Wall mounted single mixer, aerator and swivel tube spout.
Robinet évier bec orientable, aérateur

Ref.	€	📦
98501	32,00	12



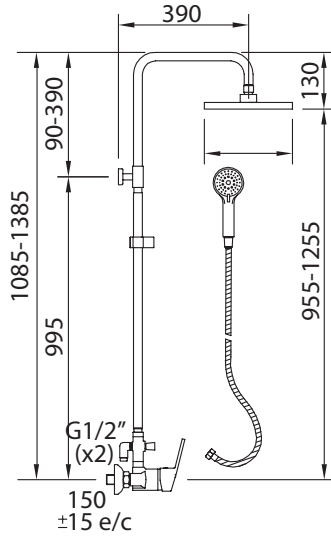

NEW

CONJUNTO DE DUCHA EXTENSIBLE
Adjustable shower system
Colonne mitigeur douche extensible

Mezclador de ducha con tubo extensible Circular (98517), soporte articulado deslizante.
Adjustable shower valve with automatic diverter.
Support douchette coulissant, inverseur automatique, pomme de douche, douchette et flexible

Incluye
Includes
Inclus



Circular
98518



Tanganyika 5F
97994



1,75 m
97670



Ceilan ø25
96264



Support
98497



Antao
96120

	Ref.	€	
ec1	98909	340,00	1

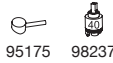

95175 98237

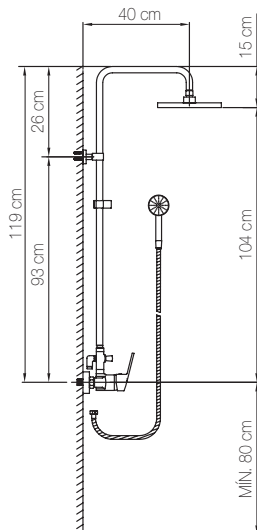

NEW

CONJUNTO DE DUCHA
Shower system
Colonne mitigeur douche

Mezclador de ducha soporte articulado deslizante.
Adjustable shower valve with automatic diverter.
Ensemble de douche, pomme de douche supérieure articulée, douchette et flexible.

Incluye
Includes
Inclus



Circular
98518



Syvari 3F
98884



1,75 m
97670



ø20
98997



Support
98998



Antao
96120

	Ref.	€	
ec1	99308	309,00	1



96175 98237

⚠ NO EXTENSIBLE
NOT EXTENDABLE.
NON EXTENSIBLE



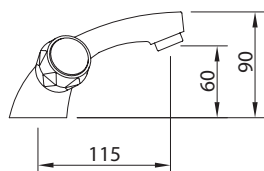

With2 guayama



LAVABO 60

Basin mixer 60 | Mélangeur lavabo 60

Mezclador con aireador y flexibles M-10 3/8" x 370 mm.
Mixer, aerator, flexible hoses M-10 3/8" x 370 mm.
Mélangeur lavabo, aérateur, raccords flexibles M-10 3/8" x 370 mm

	Ref.	€	📦
	96084	59,00	12
 	96547	67,00	12
 	97931	75,00	12



96232

96233

96208



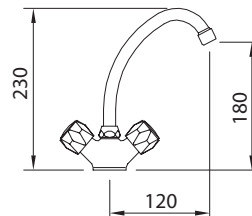

90025



LAVABO ALTO 180

Tall basin mixer 180 | Mélangeur lavabo haut 180

Mezclador con aireador, caño conformado giratorio, flexibles M-10 3/8" x 370 mm.
Mixer with aerator, swivel tube spout, flexible hoses M-10 3/8" x 370 mm.
Mélangeur lavabo, aérateur, raccords flexibles M-10 3/8" x 370 mm

	Ref.	€	📦
	98354	52,00	12
 	98355	60,00	12
 	98356	68,00	12



96232

96233

96208

90026

Productos relacionados Related products Produits connexes



PAG. 258

Urban_98650
Accesorios de baño
Bathroom accessories
Accessoires de salle de bain



PAG. 297

LEO_99398
Válvula desagüe Universal
Universal drain quick-clac
Vidage Universel



PAG. 296

SIFÓN BOTELLA LATÓN_90755
Brass bottle trap
Siphon laiton



PAG. 296

DESIGN_40010
Válvula escuadra
Angle Valve
Robinet d'equerre



BAÑO-DUCHA
Bath-shower mixer | Mélangeur bain-douche

Mezclador baño-ducha, aireador, inversor automático
Bath-shower mixer, aerator, automatic diverter.
Mélangeur bain-douche, aérateur, inverseur automatique

	Ref.	€	📦
Incluye teléfono ducha, flexo y soporte Includes handset, hose and holder Inclus douchette, flexible et support (98342, 97670, 98343)	96086	87,00	8
Sin kit ducha Without shower kit Sans kit de douche	97933	77,00	8



DUCHA
Shower mixer | Mélangeur douche

Mezclador para ducha.
Shower mixer.
Mélangeur douche

	Ref.	€	📦
Incluye teléfono ducha, flexo y soporte Includes handset, hose and holder Inclus douchette, flexible et support (98342, 97670, 98343)	96087	61,00	12
Sin kit ducha Without shower kit Sans kit de douche	97934	51,00	8

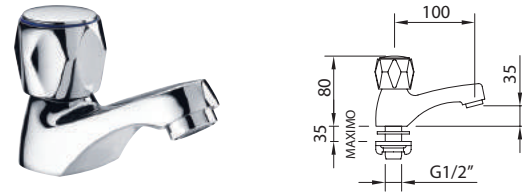
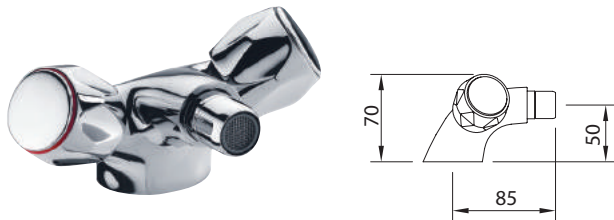

BIDÉ
Bidet mixer | Mélangeur bidet

Mezclador con aireador a rótula y flexibles M-10 3/8" x 370 mm.
Mixer, swivel aerator, flexible hoses M-10 3/8" x 370 mm.
Mélangeur bidet, aérateur rotule, raccords flexibles M-10 3/8" x 370 mm

	Ref.	€	📦
ACS	96085	59,00	12
SYNTHETIC ACS	96548	67,00	12
METALIC ACS	97932	75,00	12



GRIFERÍA SIMPLE REPISA 35
Single tap 35 | Robinet simple 35

Grifo de repisa, con aireador, índice de agua fría.
Deck mounted single basin faucet, with aerator, cold water indice.
Robinet lavabo, aérateur.

	Ref.	€	📦
ACS	96097	27,00	24



NINE SLIM urban_60414
Ducha termostática
Thermostatic shower mixer
Méligeur douche thermostatique



CITY AIR_99624
Conjunto ducha
Shower kit
Kit douche



WITH2 guayama_98451
Grifería simple mural
Wall mounted single tap
Robinet simple mural

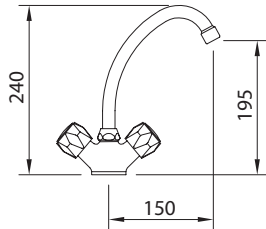

FREGADERO

Sink mixer | Mélangeur évier

Mezclador con aireador, caño conformado giratorio, flexibles M-10 3/8" x 370 mm.
 Mixer with aerator, swivel tube spout, flexible hoses M-10 3/8" x 370 mm.
 Mélangeur évier, bec orientabl, eaérateur, raccords flexibles M-10 3/8" x 370 mm

Ref.	€	📦
96088	50,00	12



96232 96233 96208 90026

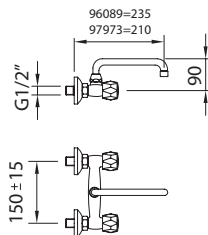

FREGADERO MURAL 150MM

Wall mounted single lever sink mixer 150 mm | Mélangeur évier mural 150 mm

Mezclador con aireador, caño conformado giratorio.
 Mixer with aerator, swivel tube spout.
 Mélangeur évier mural, bec orientable, aérateur

	Ref.	€	📦
235 mm caño, spout, bec	96089	59,00	8
210 mm caño, spout, bec	97973	59,00	8



96232 96233 96208 90026

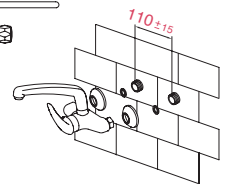
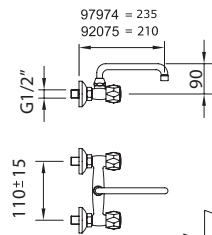

FREGADERO MURAL 110MM

Wall mounted single lever sink mixer 110 mm | Mélangeur évier mural 110 mm

Mezclador con aireador, caño conformado giratorio.
 Mixer with aerator, swivel tube spout.
 Mélangeur évier mural, bec orientable, aérateur

	Ref.	€	📦
235 mm caño, spout, bec	97974	45,00	12
210 mm caño, spout, bec	92075	45,00	12



96232 96233 94459 90026

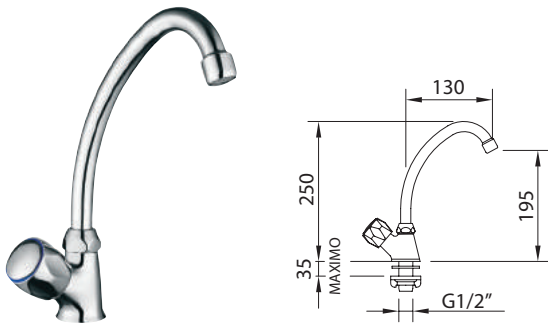

GRIFO SIMPLE REPISA
Single tap | Robinet simple

Grifo con aireador y caño conformado giratorio.
Deck mounted single faucet aerator and swivel tube spout.
Robinet évier bec orientable, aérateur

	Ref.	€	📦
	96462	31,00	8



GRIFO SIMPLE MURAL
Wall mounted single tap | Robinet simple mural

Grifo de pared con aireador y caño conformado giratorio.
Deck mounted single faucet aerator and swivel tube spout.
Robinet évier bec orientable, aérateur

	Ref.	€	📦
	96754	31,00	12



GRIFO SIMPLE MURAL
Wall mounted single tap | Robinet simple mural

Grifo de pared con aireador y caño conformado giratorio.
Deck mounted single faucet aerator and swivel tube spout.
Robinet évier bec orientable, aérateur

Ref.	€	📦
96767	31,00	12



Nine urban

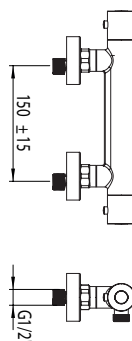



NINE SLIM urban

DUCHA TERMOSTÁTICA

Thermostatic shower mixer | Mitigeur douche thermostatique

Mezclador termostático para ducha.
Thermostatic shower mixer.
Mitigeur douche thermostatique, aérateur.

Incluye teléfono ducha, flexo y soporte
Includes handset, hose and holder
Inclus douchette, flexible et support
(98342, 97670, 98343)

	Ref.	€	📦
	60414	158,00	6
	60415	143,00	6

Sin kit ducha
Without shower set
Sans kit de douche



99652

97385

Productos relacionados
Related products
Produits connexes



PAG. 257

urban_99459
Accesorios de baño
Bathroom accessories
Accessoires de salle de bain



PAG. 45

NINE elegance 60154
Ducha termostática
Thermostatic shower mixer
Mitigeur douche thermostatique

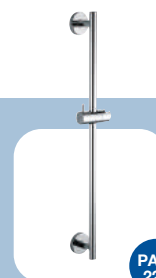

PAG. 228

STYLE_99621
Barra de ducha
Sliding bar
Barre de douche

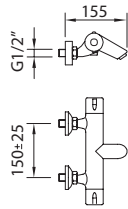

Inversor incorporado en la maneta de caudal
Diverter built in the flow handle
Inverseur intégré dans la poignée

BAÑO-DUCHA TERMOSTÁTICO
Thermostatic bath-shower mixer
Mitigeur bain-douche thermostatique
Mezclador termostático para baño-ducha.
Thermostatic bath-shower mixer.
Mitigeur bain-douche thermostatique, aérateur, inverseur céramique intégré

Incluye teléfono ducha, flexo y soporte
Includes handset, hose and holder
Inclus douchette, flexible et support
(96108, 97670, 90011)

Ref.	€	☐
98822	203,00	6
98928	188,00	6

Sin kit ducha
Without shower set
Sans kit de douche



98027 90027 98776

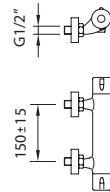

DUCHA TERMOSTÁTICA
Thermostatic shower mixer
Mitigeur douche thermostatique
Mezclador termostático para ducha.
Thermostatic shower mixer.
Mitigeur douche thermostatique

Incluye teléfono ducha, flexo y soporte
Includes handset, hose and holder
Inclus douchette, flexible et support
(96108, 97670, 90011)

Ref.	€	☐
60325	169,00	-
60326	154,00	-

Sin kit ducha
Without shower set
Sans kit de douche



98027 97385



99613
Teléfono de ducha
Handset
Douchette

99621
Barra de ducha
Sliding bar
Barre de douche

98149
Ducha termostática
Thermostatic shower mixer
Mitigeur douche thermostatique



PAG. 233

STYLE_ 99613
Teléfono de ducha
Handset
Douchette



PAG. 49

NINE XTREME_ 60133
Ducha termostática
Thermostatic shower mixer
Mitigeur douche thermostatique

Sistema COLD TOUCH
Anti-quemaduras



Inversor incorporado en la maneta de caudal
Diverter built in the flow handle
Inverseur intégré dans la poignée

Sistema COLD TOUCH
Anti-quemaduras



BAÑO-DUCHA TERMOSTÁTICO

Thermostatic bath-shower mixer | Mitigeur bain-douche thermostatique

Mezclador termostático para baño-ducha, cold touch.
Thermostatic bath-shower mixer, cold touch.
Mitigeur bain-douche thermostatique, aérateur, inverseur céramique intégré, corps froid

	Ref.	€	
Incluye teléfono ducha, flexo y soporte Includes handset, hose and holder Inclus douche, flexible et support (96108, 97670, 98208)	98823	218,00	6
Sin kit ducha Without shower set Sans kit de douche	98929	203,00	6



DUCHA TERMOSTÁTICA

Thermostatic shower mixer | Mitigeur douche thermostatique

Mezclador termostático para ducha, cold touch.
Thermostatic shower mixer, cold touch.
Mitigeur douche thermostatique, aérateur, corps froid

	Ref.	€	
Incluye teléfono ducha, flexo y soporte Includes handset, hose and holder Inclus douche, flexible et support (96108, 97670, 98208)	98478	184,00	6
Sin kit ducha Without shower set Sans kit de douche	98149	169,00	6



SISTEMA COLD TOUCH ANTI-QUEMADURAS.
Permiten que en ningún caso el cuerpo se caliente y queme.
Ideal para la seguridad infantil.

Cold touch system. Maintain the body cold. Ideal for the child security.
Robinetterie anti-brûlures. Évitez que les corps de nos douches et bains douches ne chauffent et ne brûlent.
Idéal pour la sécurité des enfants.



STANDARD SYSTEM

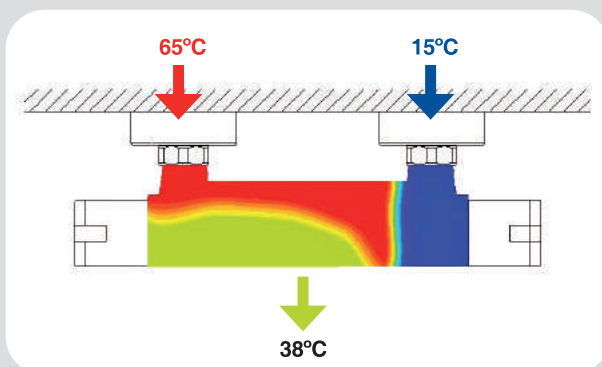

COLD TOUCH SYSTEM

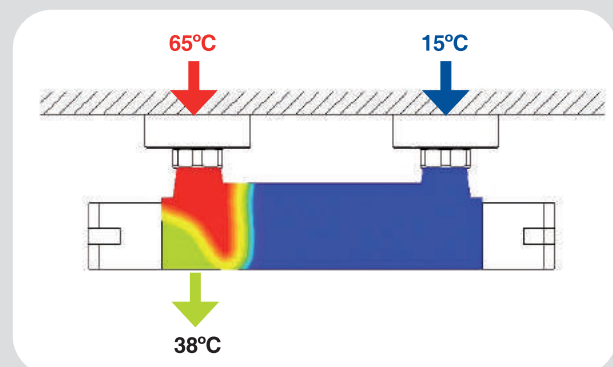

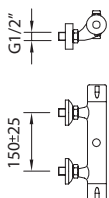

Inversor incorporado en la maneta de caudal
Diverter built in the flow handle
Inverseur intégré dans la poignée

GRIFERÍA PARA DUCHA TUBO EXTENSIBLE
Shower mixer for adjustable shower bar
Mitigeur douche thermostatique double sortie

Recambio termostático para 98761-98762-98995-60327-60328-60412-60413. 2 salidas.
Thermostatic replacement for 98761-98762-98995-60327-60328-60412-60413. 2 outlets.
Robinetterie thermostatique douche pour 98761-98762-98995-60327-60328-60412-60413. 2 sorties.

	Ref.	€	
Sin kit ducha Without shower set Sans kit de douche	98763	174,00	6



98027 98776

CONJUNTO DE DUCHA TERMOSTÁTICO
Thermostatic shower system
Colonne thermostatique douche extensible

Mezclador termostático de ducha con tubo extensible (98517), soporte articulado deslizable.
Adjustable thermostatic shower system (98517) with diverter built.
Support douchette coulissant, inverseur céramique, pomme de douche, douchette et flexible

Incluye
Includes
Inclus



Circular
98518



Tanganyika
97994



1,75 m
97670



Ceilan
96264



Support
98497

	Ref.	€	
	60327	431,00	-



98027 98776

Inversor incorporado en la maneta de caudal
Diverter built in the flow handle
Inverseur intégré dans la poignée

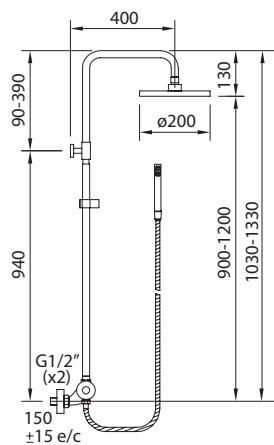

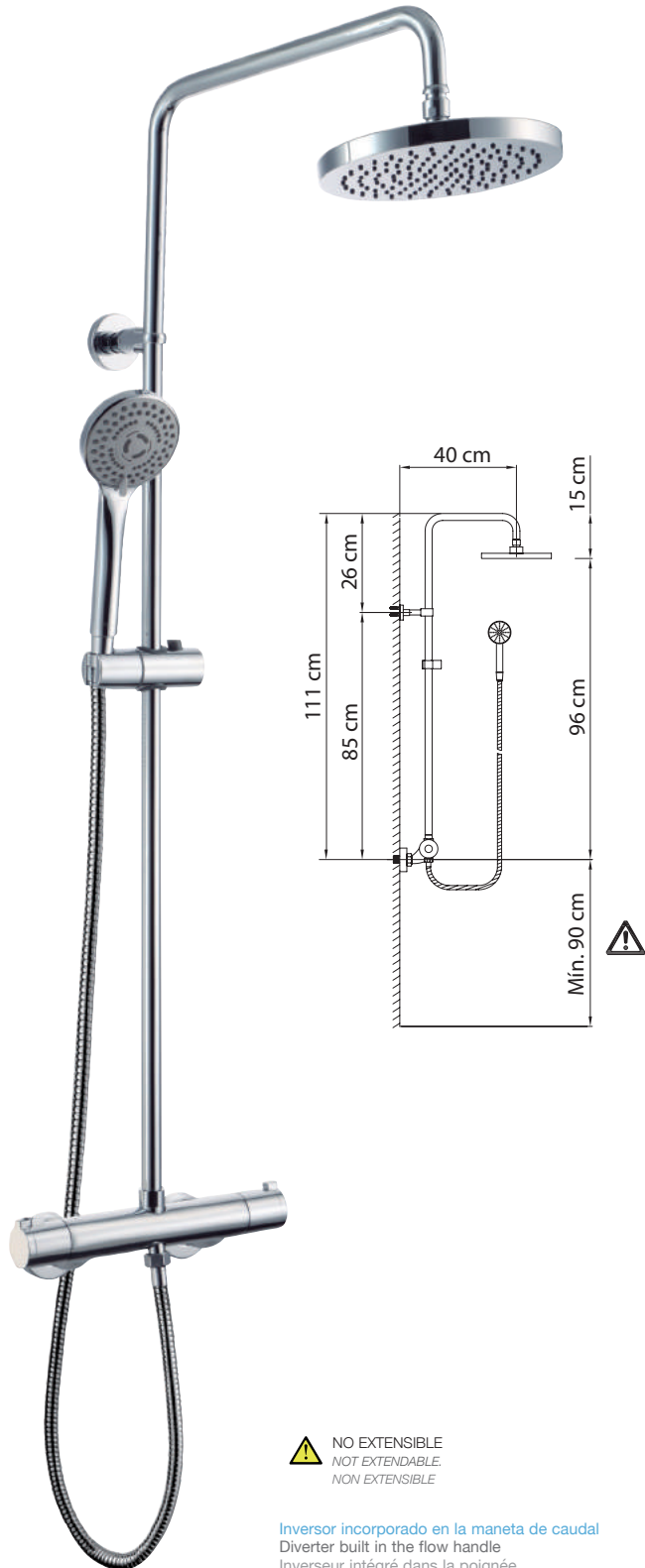

 NO EXTENSIBLE
NOT EXTENDABLE.
NON EXTENSIBLE

Inversor incorporado en la maneta de caudal
Diverter built in the flow handle
Inverseur intégré dans la poignée

CONJUNTO DE DUCHA TERMOSTÁTICO

Thermostatic shower system
Colonne thermostatique douche

Mezclador termostático de ducha soporte articulado deslizable.
Thermostatic shower valve with diverter built in.
Support douchette coulissant, inverseur céramique,
pomme de douche, douchette et flexible

Incluye
Includes
Inclus



Circular
98518



Syvari 3F
98884





1,75 m
97670



ø20
98997



Support
98998

Ref.	€	
 60328	400,00	1



98027 98776

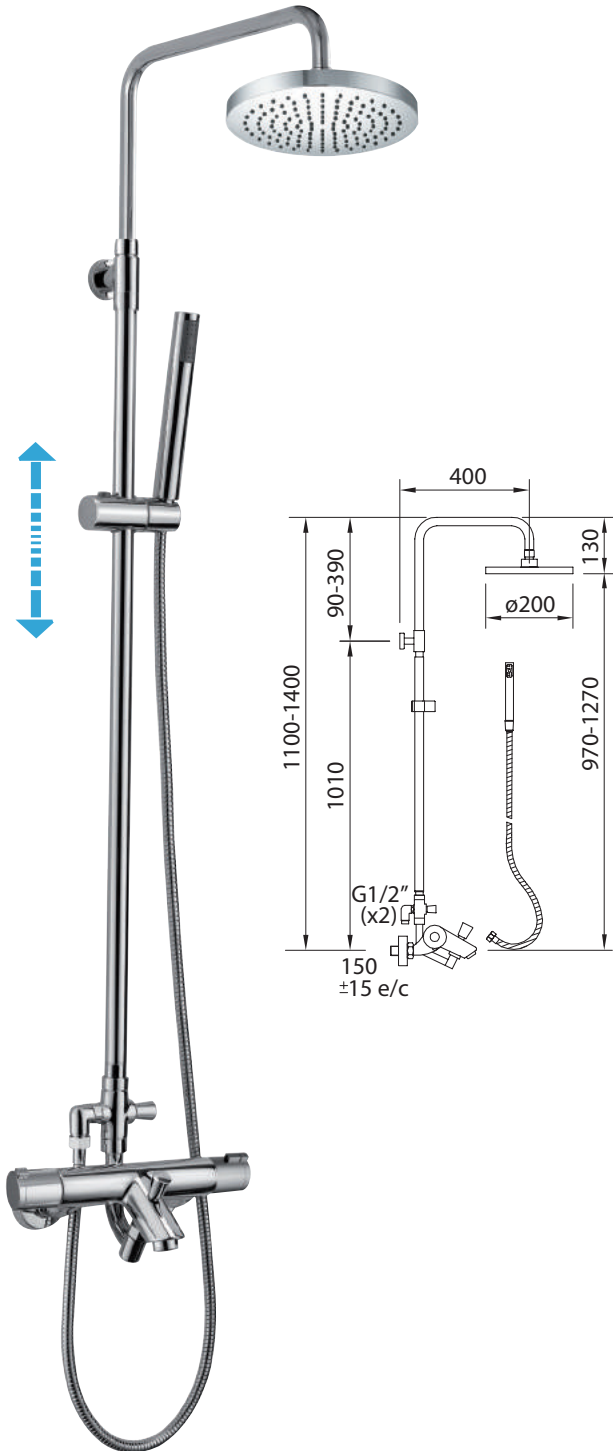

CONJUNTO DE BAÑO-DUCHA TERMOSTÁTICO
Thermostatic bath-shower system
Colonne thermostatique bain-douche extensible

Mezclador termostático de baño-ducha con tubo extensible (98517), soporte articulado deslizando. Adjustable thermostatic bath-shower system (98517) with articulated and sliding holder. Support douchette coulissant, inverseur automatique, pomme de douche, douchette et flexible

Incluye
Includes
Inclus



Ref.	€	📦
98640	466,00	4

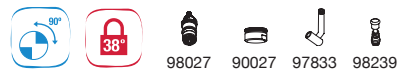

Productos relacionados
 Related products
 Produits connexes



PAG. 236

SILVER HOSE _ 98880
 Flexible. Acabado en plata
 Flexible. Silver finish
 Flexible. Finition argent



PAG. 236

FLEXIBLE _ 97114
 Cromado
 Chrome plated
 Chromé



PAG. 233

CITY AIR_ 99615
 Teléfono ducha ø 100mm
 Handset
 Douchette



PAG. 224

CITY _ 99607
 Rociador ø 225mm
 Shower head
 Pomme de douche



Calidad del agua

Water quality
Qualité de l'eau



Viveo
148



Komeo
152



FX04
156

viveo

Unidad de calidad del agua para la cocina

Smart water ultrafiltration unit for the kitchen
Equipement d'ultrafiltration pour la qualité de l'eau de la cuisine

NEW



+ FICHA TÉCNICA

- Presión de trabajo: 0'5 - 4 bar
- Rango Temperatura: 2 - 38°C
- Caudal máx. 120 L/h
- Entrada y salida: solo conexión de entrada y salida (no hay conexión con desagüe).
- Peso: 6kg
- Vida útil cartuchos:
 - 1SR y 3UM: 1 año o 10.000L
 - 2CA: 1 año o 5.000L
- Medidas: 36 x 27,5 x 9 cm

DATA SHEET

- Working pressure: 0'5 - 4 bar
- Temperature Range: 2 - 38°C
- Maximum flow 120 L/h
- In and out: only input and output connection (no connection to drain)
- Weight: 6kg
- Cartridges replacement:
 - 1SR and 3UM: 1year or 10.000L
 - 2CA: 1 year or 5.000L
- Measures: 36 x 27,5 x 9 cm

FICHE TECHNIQUE

- Pression réseau: 0'5 - 4 bar
- Température de l'eau : 2 - 38°C
- Débit maximum: 120 L/h
- Entrée/Sortie: raccords d'entrée et de sortie seulement (pas de raccord d'évacuation d'eau)
- Poids: 6kg
- Durée de vie des cartouches
 - 1SR et 3UM: 1 an ou 10.000L
 - 2CA: 1 an ou 5.000L
- Dimensions: 36 x 27,5 x 9 cm

+ LOS +

- Garantía de agua saludable y libre de impurezas.
- Notificación automática que informa al usuario cada vez que se deben reemplazar los consumibles
- Filtración que mantiene todos los minerales optimos para la salud.
- Combinación única de productos con un grifo premium de 3 vías.

BENEFITS

- Guarantees water without bacteria or viruses
- Viveo informs you when it is necessary the replacement of the cartridges
- Keeps minerals in water
- Unique combination with a 3-way premium faucet

LES +

- Viveo offre la garantie d'avoir de l'eau saine et sans impuretés
- Equipé d'un dispositif d'alerte automatique pour informer l'utilisateur dès qu'il doit changer des consommables.
- Dispose d'un système de filtration qui assure la quantité de minéraux optimum pour la santé.
- Viveo est présenté avec un Mitigeur premium 3 voies.



+ INCLUYE

- Equipado con un indicador de sonido y tres luces indicadoras. Informa automáticamente al usuario cuando es necesario reemplazar los cartuchos.
- Funciona con 2 pilas LR6 (incluidas)
- Válvula corte, conexión y tubería incluidas
- Detector de caudal incorporado

INCLUDE

- Alarm and visual indicator of consumables wear to guarantee water quality over time. Viveo informs you when it is necessary the replacement of the cartridges
- 2 x LR6 batteries
- Ball valve, fittings and pipe included
- Wear level indicator

INCLUS

- Indicateur sonore et 3 signaux lumineux informant automatiquement l'utilisateur lorsqu'il faut remplacer les consommables.
- Fonctionne avec 2 piles LR6 (piles incluses)
- Vanne d'arrêt, connexions et conduites incluses.
- Détecteur de débit incorporé

+ CARTUCHOS CARTRIDGES / CARTOUCHES

• SEDIMENTOS - 1SR

Filtra partículas y sedimentos suspendidos en el agua (5 µm)*

• SEDIMENTS- 1SR

Particles in suspension at 5µm*

• SÉDIMENTS – 1SR

Attrape les particules et les sédiments en suspension dans l'eau (5 µm)*

• ADSORCIÓN DE PARTICULAS QUÍMICAS (Filtración natural) - 2CA.

Elimina el mal sabor y olor del cloro, filtrando los pesticidas y herbicidas.

• CHEMICAL ABSORPTION (Active Carbon) - 2CA

Pesticides, herbicides, taste and smell of chlorine with activated charcoal.

• ABSORPTION CHIMIQUE (charbon actif) – 2CA

Élimine le mauvais goût et l'odeur du chlore, en filtrant les pesticides et les herbicides.

• MEMBRANA ULTRAFILTRACIÓN - 3UM

Elimina las bacterias y virus gracias a su membrana de 0,1 µm.

• UTRAFILTRATION MEMBRANE - 3UM

Bacteria and viruses with hollow fiber membrane at 0.1µm.

• MEMBRANE D'ULTRAFILTRATION – 3UM

Élimine les bactéries et les virus grâce à sa membrane de 0,1 µm.

*1 µm = 0'000001m o 0'001cm

viveo

Unidad de calidad del agua para la cocina

Smart water ultrafiltration unit for the kitchen
Équipement d'ultrafiltration pour la qualité de l'eau de la cuisine

NEW



Bienestar

Well-being / Bien-être

Proporciona agua saludable, sin sabor manteniendo los minerales.

*Provides healthy water. Keeps mineral in water, no taste of chlorine.
Fournit de l'eau saine et sans mauvais goût, tout en maintenant sa teneur en minéraux.*

Tranquilidad

Serenity / Tranquillité

Controla e informa sobre la vida útil de los cartuchos para su correcto cambio, garantizando una óptima filtración.

Controls and informs about the life of the cartridges for its correct change, guaranteeing an optimal filtration.

Contrôle et informe sur la vie utile des cartouches afin qu'elles soient changées correctement, garantissant ainsi une filtration optimum.

Confort

Comfort / Confort

Salida combinada de agua de red y filtrada en un mismo grifo.

Combined water outlet and filtered in the same tap.

Sortie combinée d'eau du réseau et d'eau filtrée avec un seul mitigeur.

Tamaño compacto

Compactness / Taille compacte

Debido a su reducido tamaño puede ser instalado debajo del fregadero.

Due to its small size it can be installed under the sink.

Sa petite taille permet son installation sous l'évier.

Facilidad de mantenimiento

Easy maintenance / Facilité d'entretien

Gracias a su sistema de notificación automática podrá cambiar el cartucho fácilmente (menos de un minuto), garantizando una filtración adecuada.

Thanks to its automatic notification system, you can easily change the cartridge (less than one minute), guaranteeing an adequate filtration.

Grâce à son système d'alerte automatique, vous pourrez changer les cartouches facilement (en moins d'une minute), garantissant ainsi une filtration adéquate.

Respeto por el medio ambiente

Environment friendly / Respect de l'environnement

No hay pérdida de agua al contrario del sistema osmosis. Se evita la producción, transporte y reciclaje de las botellas de plástico.

No water waste, contrary to the osmosis system. The production, transport and recycling of plastic bottles is avoided.

Ne génère aucune perte d'eau, contrairement au système Osmsis. Évite la production, le transport et le recyclage des bouteilles en plastique.

VIVEO

UNIDAD DE CALIDAD DEL AGUA PARA LA COCINA

Smart water ultrafiltration unit for the kitchen

Equipement d'ultrafiltration pour la qualité de l'eau de la cuisine



Medidas | Dimensions 36 x 27,5 x 9 cm

Ref.	€	📦
C75270	395,00	1

UNIDAD DE CALIDAD DEL AGUA PARA LA COCINA
CON FREGADERO 3 VIAS

Smart water ultrafiltration unit for the kitchen with sink mixer 3 ways
Equipement d'ultrafiltration pour la qualité de l'eau de la cuisine avec évier 3 voies



Ref.	€	📦
C75271	564,00	1

UNIDAD DE CALIDAD DEL AGUA PARA LA COCINA
CON GRIFO 1 VÍA

Smart water ultrafiltration unit for the kitchen with sink 1 way
Equipement d'ultrafiltration pour la qualité de l'eau de la cuisine avec robinet 1 voie

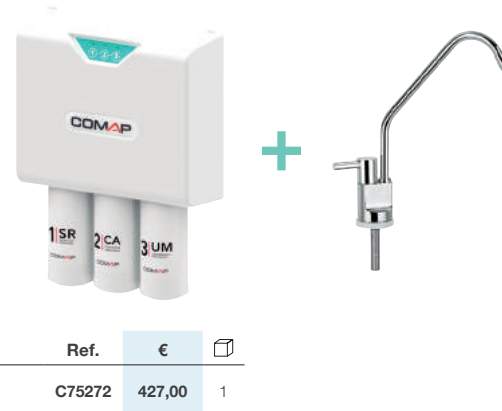

Ref.	€	📦
C75272	427,00	1

Disponible a partir del 2º semestre 2019
Available from 2nd semester 2019 / Disponible à partir du 2ème semestre 2019

RECAMBIOS

Spare parts | Pièces de rechange

CARTUCHO 1 - SR
1-SR Cartridge | Cartouche 1-SR



Ref.	€	📦
C75273	29,00	1

CARTUCHO 2 - CA
2-CA Cartridge | Cartouche 2-CA



Ref.	€	📦
C75274	29,00	1

CARTUCHO 3 - UM
3-UM Cartridge | Cartouche 3-UM



Ref.	€	📦
C75275	55,00	1

komeo

Unidad de calidad del agua para el hogar

Smart water ultrafiltration unit for home

Équipement d'ultrafiltration pour la qualité de l'eau pour la maison

Innovación en el tratamiento del agua

Water Treatment innovation

Innovation dans le traitement de l'eau

Las mejoras de la unidad de Komeo son el resultado directo de la experiencia en el desarrollo de sistemas de tratamiento de agua de COMAP.

Durante más de 30 años, las soluciones de COMAP han tenido la reputación de cumplir los requisitos más estrictos en términos de calidad del agua.

Toda la gama de productos de tratamiento de agua COMAP está **diseñada, fabricada e inspeccionada en nuestro sitio industrial con certificación ISO 9001 en Montélier, en el sur de Francia.**

The enhancements of the Komeo water treatment unit are the direct result of COMAP Water Treatment expertise in the development of water treatment systems.

For more than 30 years, COMAP Water Treatment solutions have been reputed as meeting the most stringent requirements in terms of water quality.

*The entire COMAP Water Treatment product range is **designed, manufactured and inspected on our ISO 9001-certified industrial site in Montélier in the south of France.***

Les avancées de la centrale de traitement de l'eau Komeo sont directement issues du savoir-faire de COMAP Water Treatment en développement de matériels de traitement d'eau.

Depuis plus de 30 ans, les solutions COMAP Water Treatment sont réputées pour répondre aux exigences les plus rigoureuses en matière de qualité de l'eau.

*L'ensemble des produits de la gamme de COMAP Water Treatment **est élaboré, fabriqué et contrôlé sur le site industriel certifié ISO 9001 de Montélier dans la Drôme.***



Tratamiento profesional en toda la casa

Professional treatment throughout the home

Un traitement professionnel pour tout l'habitat

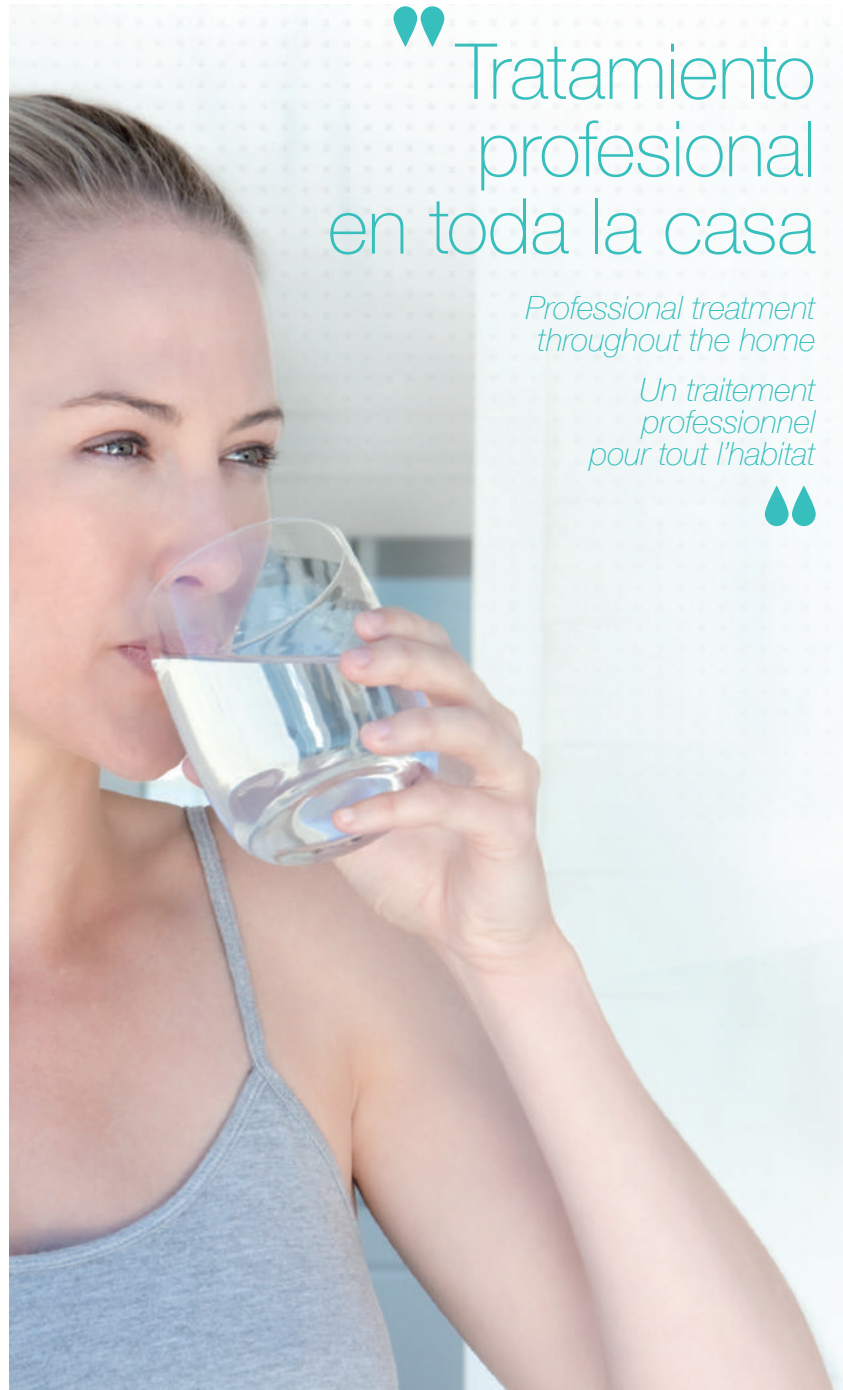

Conectado

Connected/Connectée

La aplicación Komeo para tabletas y teléfonos inteligentes **permite monitorear el consumo de agua en tiempo real.**

Komeo se puede configurar de forma remota a través de su red Wi-Fi.

Se le informa automáticamente de cualquier mal funcionamiento del sistema (estado de desgaste de los consumibles, fugas, exceso de presión, etc).

*The Komeo application for tablet and smartphone allows **water consumption to be monitored in real time.** Komeo can be configured remotely through your Wi-Fi network. **You are automatically informed of any system malfunction** (wear status of consumables, leaks, excess pressure, etc).*

*L'application Komeo pour tablette et smartphone vous permet de **suivre votre consommation d'eau en temps réel.** Le réglage de Komeo est possible à distance via votre réseau Wi-Fi. **Vous êtes informé automatiquement** d'éventuels dysfonctionnements sur votre réseau (état d'usure des consommables, fuites, surpressions ...).*



COMAP

+ INHIBIDOR DE CAL ELECTRÓNICO

- Protege las tuberías y los electrodomésticos de la incrustación

ELECTRONIC DESCALING

- Protects pipes and household electrical appliances from scaling

ANTITARTRE ÉLECTRONIQUE

- Protège du tartre les canalisations et les appareils électroménagers

+ PREFILTRO DE AUTO LIMPIEZA

- Atrapa sedimentos y partículas suspendidas en el agua.
- Purga automática, sin quitar el cartucho. Se puede activar a distancia a través de la válvula de potencia.

SELF-CLEANING PREFILTER

- Traps sediment and particles suspended in the water.
- Automatic purge, without removing the cartridge. Can be remotely activated through the power-valve.

PRÉFILTRE AUTONETTOYANT

- Retient les sédiments et particules en suspension dans l'eau.
- Purge automatiquement sans démontage des cartouches, déclenchable à distance grâce à la vanne motorisée.

+ PANTALLA TÁCTIL INTERACTIVA

- Información en tiempo real: consumo de agua, estado de desgaste de los consumibles, mal funcionamiento, etc.
- Puede ser controlado desde una tableta o teléfono inteligente.

INTERACTIVE TOUCH SCREEN

- Real time information: water consumption, wear status of consumables, malfunctions, etc.
- Can be controlled from a tablet or smartphone

ÉCRAN TACTILE ET INTERACTIF

- Informe en temps réel: consommation d'eau, usure des consommables, dysfonctionnements ...
- Pilotable avec une tablette ou un smartphone.



+ DOS FILTROS DE CARBONO

- Filtra pesticidas y herbicidas
- Trata metales pesados y manganeso
- Reduce el contenido de nitrato
- Elimina el mal sabor del cloro

TWO ACTIVATED CARBON FILTERS

- Filter out pesticides and herbicides
- Treat heavy metals and manganese
- Reduce nitrate content
- Remove the bad taste of chlorine

DOUBLE FILTRATION "CHARBON ACTIF"

- Filtre les pesticides et herbicides
- Traite les métaux lourds et le manganèse
- Réduit la présence des nitrates
- Supprime le mauvais goût de chlore

+ SENSORES DE SEGURIDAD

- Detecta fugas y exceso de presión, y corta automáticamente la red si es necesario

SAFETY SENSORS

- Detect leaks and excess pressure, and automatically cut off the network if necessary

CAPTEURS DE SÉCURITÉ

- Détectent les fuites, les surpressions et coupent automatiquement le réseau au besoin

+ LÁMPARA UVC

- Neutraliza bacterias, virus, moho y fermentación, y previene el desarrollo de legionella en redes de agua.

UVC LAMP

- Neutralises bacteria, viruses, mould and fermentation, and prevents the development of legionella in water networks.

LAMPE UVC

- Neutralise les bactéries, virus, moisissures, levures et prévient le développement de légionelles dans le réseau d'eau.

komeo

Unidad de calidad del agua para el hogar

Smart water ultrafiltration unit for home
Équipement d'ultrafiltration pour la qualité de l'eau pour la maison

Ecología Medio ambiente

Ecology. Environment / Écologie. Environnement

Komeo es una solución ecológica, **sin tratamiento químico ni rechazo de sal.**

A diferencia de los descalcificadores, Komeo no desperdicia agua a través de los ciclos de regeneración.

*Komeo is an environmentally-friendly solution, **with no chemical treatment or salt rejection.** Unlike softeners, Komeo does not waste any water through regeneration cycles.*

*Komeo respecte l'environnement en **s'affranchissant de tout traitement chimique et de tout rejet de sel.** Contrairement aux adoucisseurs, Komeo évite tout gaspillage d'eau lié aux cycles de régénération.*

LA ALTERNATIVA PARA COMPRAR AGUA EMBOTELLADA:

- **Ahorre casi 2000 botellas por año**, para una familia de 4 personas, cada una bebiendo un promedio de 2 litros de agua por día.
- **Sin transporte, sin embalaje.**

THE ALTERNATIVE TO PURCHASING BOTTLED WATER:

- **Save almost 2,000 bottles per year**, for a family of 4 people, each drinking an average of 2 litres of water per day.
- **No transport, no packaging.**

L'ALTERNATIVE À L'ACHAT D'EAU MINÉRALE:

- **Près de 2 000 bouteilles économisées par an**, pour une famille de 4 personnes buvant chacune en moyenne 2 litres d'eau / jour.
- **Pas de transport, pas d'emballage.**

KOMEO DETECTA FUGAS

- Las fugas representan del 15 al 20% del consumo anual de agua en el hogar.
- Un grifo que gotea representa de 4 a 5 litros por hora, es decir, 35 a 44 m³ / año.

KOMEO DETECTS LEAKS

- Leaks represent 15 to 20% of annual household water consumption
- A dripping tap represents 4 to 5 litres per hour, i.e. 35 to 44 m³ / year

KOMEO DÉTECTE LES FUITES

- Les fuites dans l'habitat représentent 15 à 20% de l'eau consommée en moyenne par an.
- Un robinet qui fuit goutte-à-goutte représente 4 à 5 litres/heure, soit 35 à 44 m³ / an.

DID YOU KNOW?



Medidas | Dimensions 60x60cm

UNIDAD DE CALIDAD DEL AGUA PARA EL HOGAR
 Smart water ultrafiltration unit for home
 Equipement d'ultrafiltration pour la qualité de l'eau pour la maison

Ref.	€	📦
C75236	3.462,00	1

RECAMBIOS

Spare parts | Pièces de rechange



LÁMPARA 25 W UVc
 Lamp 25 W UVc | Lampe 25 W UVc

Ref.	€	📦
C75239	82,00	1

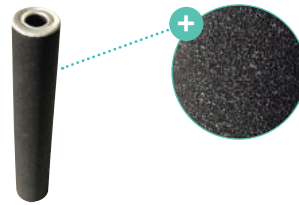

CARTUCHO BIRM
 BIRM Cartridge | Cartouche BIRM

Ref.	€	📦
C75245	46,00	1

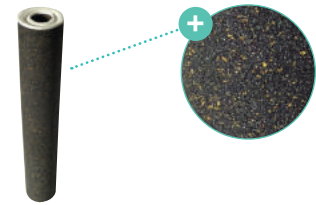

CARTUCHO KDF
 KDF Cartridge | Cartouche KDF

Ref.	€	📦
C75238	81,00	1

Para instalar el Komeo necesitas los siguientes productos relacionados:

To install the Komeo you need the following related products:
 Pour installer Komeo, vous aurez besoin des produits suivants:



Cod. 35262

Válvula de esfera roscar 3/4" M-M palanca

Threaded Brass Ball valves 3/4" M-M

Vanne à boisseau sphérique 3/4" M-M

3 ud.



Cod. C59092

Te igual ø20 Tee ø20

Té égal ø20

2 ud.



Cod. C42112

Tubería multicapa ø20

Multilayer pipe ø20
 Tube Multicouche ø20

1 ud.



Cod. C59196

Racor roscado móvil hembra junta plana ø20x2-3/4" Manifold Connector F (Washer) Ø20x2-3/4"

Raccord droit à sertir à écrou tournant Ø20x2-3/4"

4 ud.



-

Latiguillo 3/4" H-H Hose bib 3/4" F-F

Flexible 3/4" F-F

2 ud.



Instalación recomendada
 Recommended installation
 Installation recommandée

FX04 Mini filtro para grifo de cocina

Mini filter for kitchen tap | Mini filtre pour robinet de cuisine



El **mini filtro FX04** se integra perfectamente en cualquier cocina mediante 7 adaptadores para grifos con o sin aireador, proporcionando agua de altísima calidad, higiénica y con buen sabor directamente del grifo de su cocina.

Su estructura microporosa con 3 niveles de filtración (rejilla de filtración, carbón activo y fibra hueca con 3 capas) filtra el agua sin modificar su composición natural (sales minerales, oligoelementos, etc).

Ideal para beber, para infusiones y para cocinar. Conserva la riqueza natural del agua y permite ahorrar en agua embotellada.

FX04 mini filter fits perfectly in any kitchen due to 7 adapters for taps with or without aerators, providing high quality water, hygienic and with a good taste directly from the tap of your kitchen.

Its microporous structure with 3 levels of filtration (mesh strainer filtration, activated carbon and hollow fiber with 3 layers) filters the water without modifying its natural composition (mineral salts, trace elements, etc).

Ideal for drinking, infusions and cooking. Preserves the natural wealth of water and saves on bottled water.

Le mini filtre FX04 peut s'installer dans toutes les cuisines grâce à ses 7 adaptateurs pour robinet avec ou sans aérateur, permettant d'obtenir une eau d'excellente qualité, hygiénique et avec un goût agréable directement depuis le robinet de votre cuisine.

Sa structure microporeuse avec 3 niveaux de filtration (grille de filtration, charbon actif et 3 couches de fibre creuse) filtre l'eau sans en modifier la composition naturelle (sels minéraux, oligo-éléments, etc.)

Idéal pour boire, faire des infusions ou cuisiner. Conserve la richesse naturelle de l'eau et permet de faire des économies d'eau en bouteille.



MINIFILTRO FX04 Con cartucho incluido
Mini filter FX04 With cartridge included
Mini filtre FX04 Avec cartouche incluse

Caudal / Flow / Débit 150-180 l/h



Ref.	€	
C75191	79,00	1

Los + del producto

The main points of the product / Les + produit

- 1** Elimina el mal olor y sabor a cloro
Removes the bad smell and the chlorine taste / Élimine l'odeur et le goût du Chlore.
- 2** Reduce las impurezas
Reduces the contaminant / Réduit les impuretés
- 3** Reduce metales pesados
Reduces the heavy metals / Réduit la teneur en métaux lourds
- 4** Reduce herbicidas y pesticidas
Reduces the weed-killer and the pesticides / Réduit la teneur en herbicides et pesticides
- 5** Reduce la presencia de bacterias
Reduces the bacteria presence / Réduit la présence de bactéries
- 6** Reduce la presencia de micro-contaminantes
Reduces the micro contaminating presence / Réduit la présence de micro-contaminants
- 7** Micro filtración (0,1 µ m)
Micro filtration (0,1 µ m) / Micro filtration (0,1 µ m)
- 8** Instalación sencilla, sin herramientas
Easy installation, without tools / Installation simple, sans besoin d'outils
- 9** Económico y fácil de usar
Cheap and easy to use / Économique et facile à utiliser.

Tuerca de fijación
Fixation nut/ Écrou de fixation

Palanca de selección
Selection lever/ Levier de sélection



Kit de adaptadores
Adapters kit/ Kit d'adaptateurs

Salida de agua filtrada
Filtered water outlet/ Sortie d'eau filtrée

Cartucho
Cartridge/ Cartouche

Tapa con visor de cartucho
Couvercle avec viseur de cartouche

Salida de agua no filtrada
Unfiltered water outlet/ Sortie d'eau non filtrée

Couvercle avec viseur de cartouche

Control de selección "click-clack" para las posiciones 1, 2 y 3.

Selection control "click-clack" for the positions 1, 2 and 3.

Contrôle de sélection "click-clack" pour les positions 1, 2, 3.

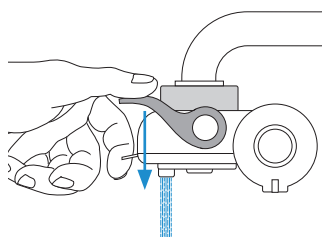

Posición/Position 1

Posición/Position 2

Posición/Position 3

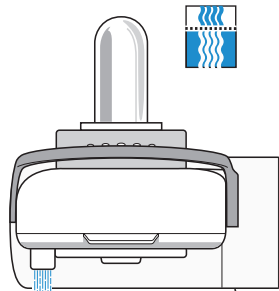

Chorro
El agua está filtrada

*Jet. Water is filtered
Jet. L'eau est filtrée*

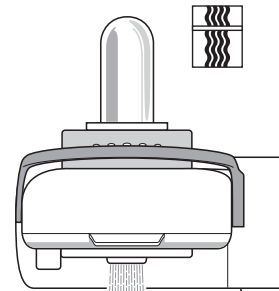

Chorro
El agua no está filtrada

*Jet. Water is not filtered
Jet. L'eau n'est pas filtrée*

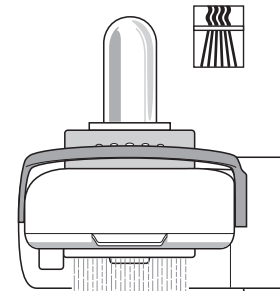

Ducha
El agua no está filtrada

*Shower. Water is not filtered
Douche. L'eau n'est pas filtrée*



COCINA



Grifería para calidad del agua
 Water quality taps
 Robinetterie pour une eau de qualité
 162



Abatible
 Folding spout
 Bec rabattable
 166



Chef
 168

Clever en tu cocina

Clever in your kitchen / Clever dans votre cuisine



Platinum
178



Styles
182



Styles Pro
188



Gerontológico
Medical lever
Manette P.M.R.
202

Cocina Kitchen / Cuisine

grifería para equipos de calidad del agua

Water quality equipment taps
Robinets d'équipement de qualité de l'eau

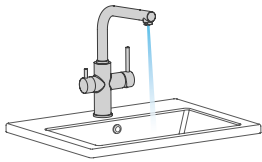

agua filtrada vertical
vertical water filtered | eau purifiée
vertical

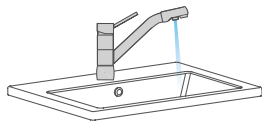

agua filtrada horizontal
horizontal water filtered | eau purifiée hori-
zontal

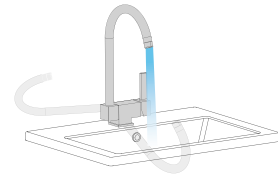

abatible
folding spout | bec rabattable

Platinum

Styles monomando

single lever | mitigeur

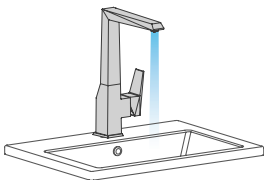

vertical
vertical | vertical



vertical
vertical | vertical

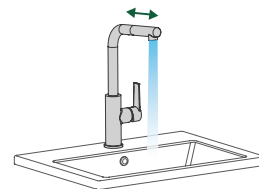

extraíble
pull out | extractible

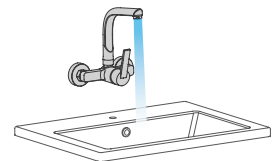

mural
wall mounted | mural

Styles pro monomando

single lever | mitigeur

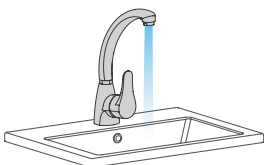

vertical
vertical | vertical

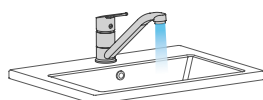

horizontal
horizontal | horizontal

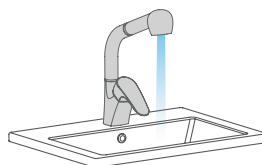

extraíble
pull out | extractible

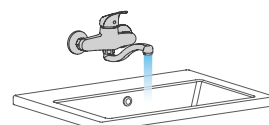

mural
wall mounted | mural



1 agua
1 water | 1 eau

Escoje el grifo que más encaja contigo

Choose your favorite tap / Choisissez votre robinet préféré

chef

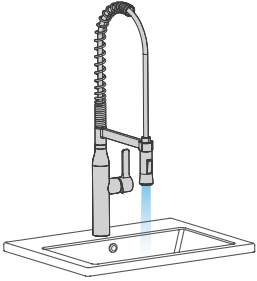

chef profesional
professional | industriel

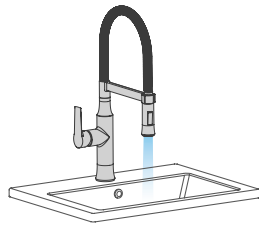

chef semi profesional
semi-professional | type industriel

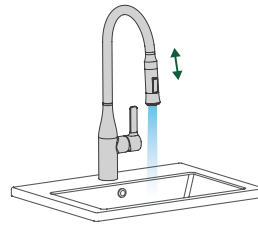

chef extraíble
pull out | extractible

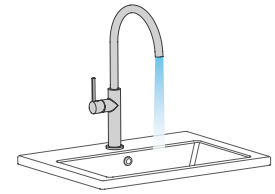

chef básico
basic | simple

Styles bimando

two handle | mélangeur



vertical
vertical | vertical



vertical
vertical | vertical

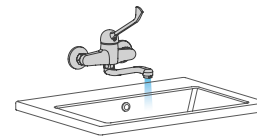

mural
wall mounted | mural

Gerontológico

medical lever | manette P.M.R.

Styles pro bimando

two handle | mélangeur



vertical
vertical | vertical

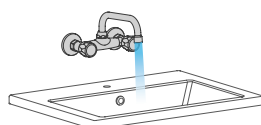

mural
wall mounted | mural



1 agua
1 water | 1 eau

Grifería para equipos de calidad del agua

Water quality equipment taps | Robinets d'équipement de qualité de l'eau

NUEVO GRIFO SEMIPROFESIONAL PARA EQUIPOS DE CALIDAD DEL AGUA

NEW

*New drinking water sink mixer
Nouveau mitigeur évier avec sortie eau purifiée*



Sistema magnético de sujeción de la pistola

*Magnet system to grab the dishwashing pull-out
Dispositif aimanté pour maintenir la douchette*



Mantenemos el **diseño** de las **Chef**, pero más funcional con **3 vías**.

*We maintain the Chef design, but more useful with its 3 ways
Nous maintenons le design des mitigeurs évier CHEF, mais en le rendant plus fonctionnel grâce à ses 3 voies.*

CHEF WT 19
Ref. 60729

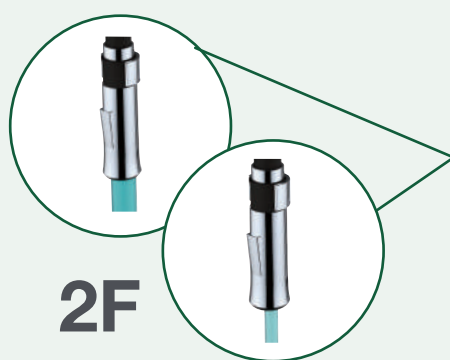

2F

Salida de agua mezclada

Mixed water outlet - Sortie d'eau mitigée



Salida de agua filtrada

Filtered water outlet - Sortie d'eau purifiée

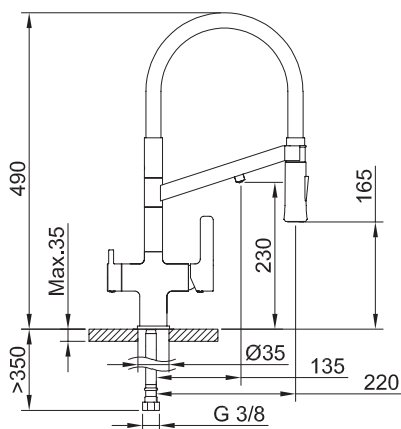

CHEF WT 19

FREGADERO SEMIPROFESIONAL DE 3 VIAS PARA EQUIPOS DE CALIDAD DEL AGUA

3 way semiprofessional sink mixer for water quality equipment
Mitigeur évier semiprofessionnel à 3 voies pour équipement de qualité de l'eau

Fregadero Agua filtrada con 2 salidas de agua, flexibles M-10 3/8" x 420 mm

Water quality sink mixer with 2 outflows, flexible hoses M-10 3/8" x 420 mm.

Mitigeur évier pour eau purifiée, aérateur/buse intégré, raccords flexibles M-10 3/8" x 420 mm

Ref.	€	
ec3 60729	320,00	

Incluye
Includes
Inclus



Adaptador para tubo PE 1/4" - 7/16"-24 H.
Adapter for PE 1/4" - 7/16"-24 F pipe.
Adaptateur tube PE 1/4" - 7/16"-24 H.



60733 99656 97698 97688 98759

Lixiv Rain-Plus Spray



NUEVO GRIFO DE COCINA ABATIBLE PARA EQUIPOS DE CALIDAD DEL AGUA

*New drinking water sink mixer with folding spout
Nouveau mitigeur à bec rabattable et orientable
avec sortie pour eau purifiée*

Agua mezclada y Agua
filtrada desde una sola
maneta (Ver Fig.1 y 2)

*Mixed water and filtered water on the
same handle (See Fig.1 and 2)
Eau du réseau et eau purifiée depuis
une seule manette*



ABATIBLE FS 19
Ref. 60731

QUORE

Fig.1

Salida progresiva de agua mezclada
*Progressive mixed water outlet
Sortie d'eau progressif mitigée*

Fig.2

Salida de agua filtrada
Filtered water outlet - Sortie d'eau purifiée

ABATIBLE FS 19

FREGADERO ABATIBLE DE 3 VIAS PARA EQUIPOS DE CALIDAD DEL AGUA

3 way sink mixer for water quality equipment with folding spout

Mitigeur évier 3 voies à bec rabattable et orientable pour équipement de qualité de l'eau

Fregadero abatible agua filtrada con 2 salidas de agua combinadas, flexibles M-10 3/8" x 420 mm
Water quality sink mixer with folding spout with 2 outflows, flexible hoses M-10 3/8" x 420 mm.

Mitigeur évier à bec rabattable et orientable avec sortie pour eau purifiée, aérateur/buse intégré, raccords flexibles M-10 3/8" x 420 mm

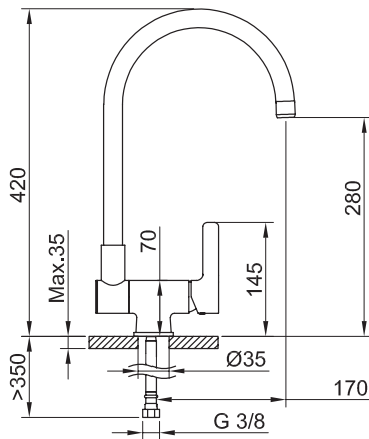

Ref.	€	📦
60731	207,00	-

Incluye
Includes
Inclus

Adaptador para tubo PE 1/4" - 7/16"-24 H.
Adapter for PE 1/4" - 7/16"-24 F pipe.
Adaptateur tubo PE 1/4" - 7/16"-24 H.



Grifería para equipos de calidad del agua

Water quality equipment taps | Robinets d'équipement de qualité de l'eau

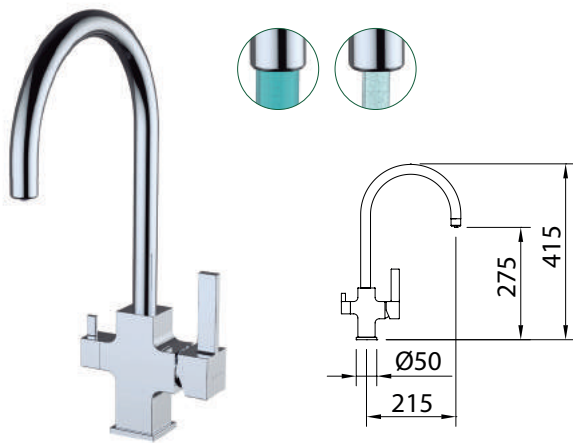

SQUARE

FREGADERO 3 VIAS PARA EQUIPOS DE CALIDAD DEL AGUA 3 way sink mixer for water quality equipment | Mitigeur évier 3 voies pour équipement de qualité de l'eau

Fregadero Agua filtrada con 2 salidas de agua combinadas, flexibles M-10 3/8" x 370 mm
Water quality sink mixer with 2 outflows, flexible hoses M-10 3/8" x 370 mm.
Mitigeur évier pour eau purifiée, aérateur/buse intégré, raccords flexibles M-10 3/8" x 370 mm

	Ref.	€	📦
	60151	207,00	4

Incluye
Includes
Inclus 97399 Adaptador para tubo PE 1/4" - 7/16"-24 H.
Adapter for PE 1/4" - 7/16"-24 F pipe.
Adaptateur tubo PE 1/4" - 7/16"-24 H.

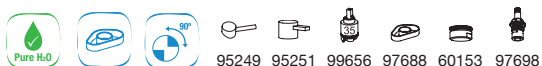

95249 95251 99656 97688 60153 97698

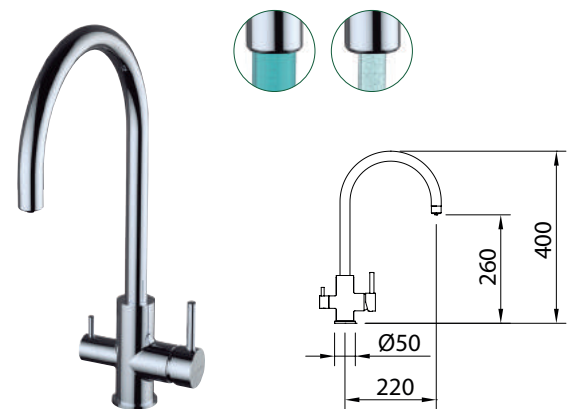

ROUND

FREGADERO 3 VIAS PARA EQUIPOS DE CALIDAD DEL AGUA 3 way sink mixer for water quality equipment | Mitigeur évier 3 voies pour équipement de qualité de l'eau

Fregadero Agua filtrada con 2 salidas de agua combinadas, flexibles M-10 3/8" x 370 mm
Water quality sink mixer with 2 outflows, flexible hoses M-10 3/8" x 370 mm.
Mitigeur évier pour eau purifiée, aérateur/buse intégré, raccords flexibles M-10 3/8" x 370 mm

	Ref.	€	📦
	60150	179,00	4

Incluye
Includes
Inclus 97399 Adaptador para tubo PE 1/4" - 7/16"-24 H.
Adapter for PE 1/4" - 7/16"-24 F pipe.
Adaptateur tubo PE 1/4" - 7/16"-24 H.

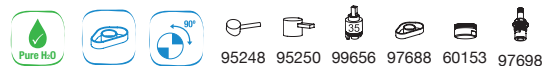

95248 95250 99656 97688 60153 97698

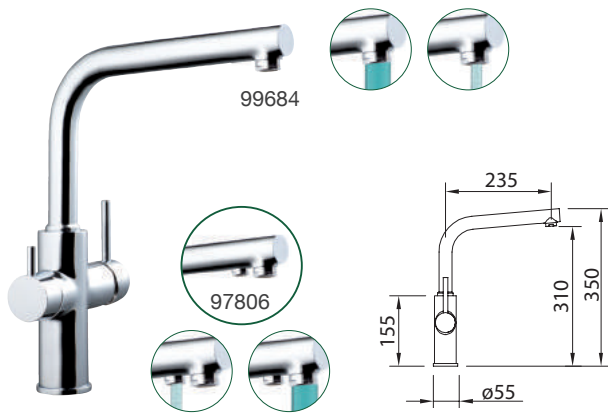

FREGADERO 3 VIAS PARA EQUIPOS DE CALIDAD DEL AGUA
3 way sink mixer for water quality equipment | Mitigeur évier
3 voies pour équipement de qualité de l'eau

Fregadero Agua filtrada con 2 salidas de agua, flexibles M-10 3/8" x 370 mm
 Water quality sink mixer with 2 outflows, flexible hoses M-10 3/8" x 370 mm.
 Mitigeur évier pour eau purifiée, aérateur/buse intégré, raccords flexibles M-10 3/8" x 370 mm

	Ref.	€	
	99684	189,00	4
	97806	189,00	4

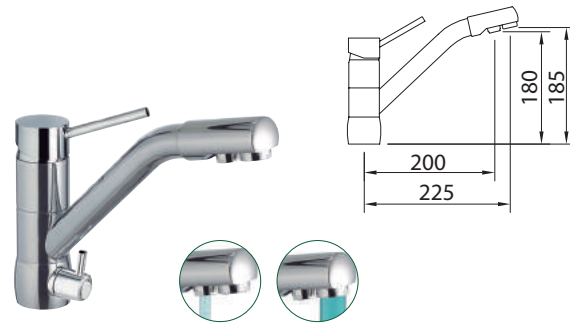
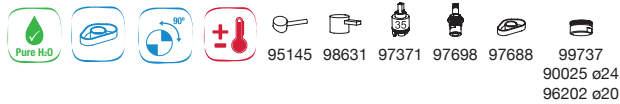

FREGADERO 3 VIAS PARA EQUIPOS DE CALIDAD DEL AGUA
3 way sink mixer for water quality equipment | Mitigeur évier
3 voies pour équipement de qualité de l'eau

Fregadero Agua filtrada con 2 salidas de agua, caño giratorio, flexibles M-10 3/8" x 370 mm
 Water quality sink mixer with 2 outflows, flexible hoses M-10 3/8" x 370 mm.
 Mitigeur évier pour eau purifiée, aérateur/buse, raccords flexibles M-10 3/8" x 370 mm

	Ref.	€	
	98760	207,00	8

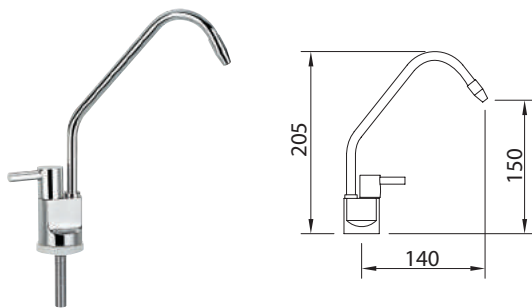
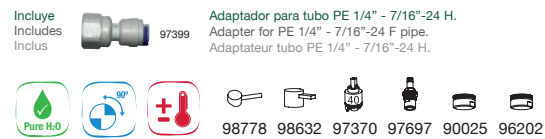

GRIFERÍA AGUA FILTRADA
Water quality sink | Robinet avec sortie eau purifiée

Grifería Agua filtrada, caño giratorio.
 Water quality sink, swivel spout.
 Robinet évier pour eau purifiée, avec buse

Ref.	€	
97104	47,00	20

Incluye Includes Inclus 97399 Adaptador para tubo PE 1/4" - 7/16"-24 H. Adapter for PE 1/4" - 7/16"-24 F pipe. Adaptateur tubo PE 1/4" - 7/16"-24 H.



SISTEMA SALIDA AGUA FILTRADA
Ref. 99684 - 60150 - 60151 - 60731

Outlet Water quality system / Système de sortie d'eau purifiée

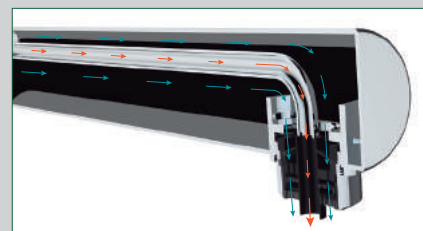

No existe comunicación entre el conducto de agua mezclada y el de agua filtrada.
 It does not exist any contact between the mixed water channel and the filtered one.
 Il n'y a aucun contact entre l'eau mitigée et l'eau purifiée

Abatible

Folding spout | Bec rabattable



Grifería abatible para fregaderos con ventanal.

Con esta grifería podrás abrir la ventana de la cocina sin obstáculos.

La grifería se inclina completamente evitando así que obstaculice la ventana. Se abate con un suave gesto, y dispone de varios puntos de fijación. Vuelve a su posición vertical fácilmente.

Practical solution for sinks below a window.

With this kitchen tap you can open the window without obstacles.

Practical solution for sink mixers below a window. With this kitchen tap you can open the window without any obstacle. The tap totally bends softly allowing to open the window without any inconvenience. You can return the spout to its original position easily.

Une robinetterie rabattable pour les éviers situés devant une fenêtre.

Avec ces robinets vous pourrez ouvrir la fenêtre de votre cuisine sans obstacles.

Les robinets s'inclinent complètement, sans gêner l'ouverture de la fenêtre. Ils se rabattent avec un simple geste, et disposent de plusieurs points de fixation. Ils retournent facilement à leur position verticale.

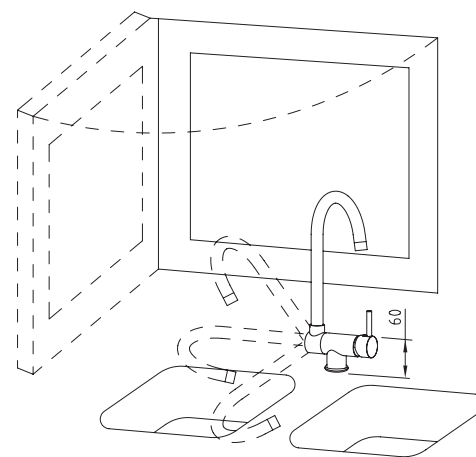



NEW

ABATIBLE FS 19

FREGADERO ABATIBLE DE 3 VIAS PARA EQUIPOS DE CALIDAD DEL AGUA

3 way sink mixer for water quality equipment with folding spout
Mitigeur évier 3 voies à bec rabattable et orientable pour équipement de qualité de l'eau

Fregadero abatible agua filtrada con 2 salidas de agua combinadas, flexibles M-10 3/8" x 420 mm

Water quality sink mixer with folding spout with 2 outflows, flexible hoses M-10 3/8" x 420 mm.

Mitigeur évier à bec rabattable et orientable avec sortie pour eau purifiée, aérateur/buse intégré, raccords flexibles M-10 3/8" x 420 mm



VER PÁGINA 163

See pag. / Voir la page

Ref.	€	📦
60731	207,00	-

Incluye / Includes / Inclus  97399 Adaptador para tubo PE 1/4" - 7/16"-24 H. / Adapter for PE 1/4" - 7/16"-24 F pipe. / Adaptateur tubo PE 1/4" - 7/16"-24 H.



SQUARE ABATIBLE

FREGADERO CAÑO ABATIBLE

Sink mixer with folding spout / Mitigeur évier à bec rabattable

Fregadero caño abatible 180°, aireador, caño conformado giratorio, flexibles M-10 3/8" x 370 mm
 Deck mounted sink mixer 180° foldingspout, aerator, swivel tube spout, flexible hoses M-10 3/8" x 370 mm.
 Mitigeur évier bec rabattable, aérateur, raccords flexibles M-10 3/8" x 370 mm

Ref.	€	📦
ec3  60152	169,00	4

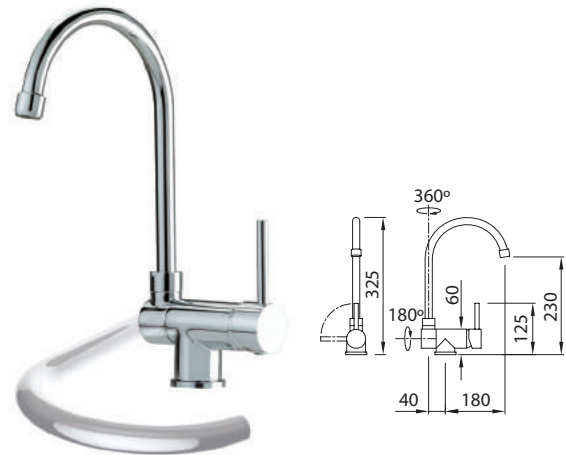

FREGADERO CAÑO ABATIBLE

Sink mixer with folding spout / Mitigeur évier à bec rabattable

Fregadero caño abatible 180°, aireador, caño conformado giratorio, flexibles M-10 3/8" x 370 mm
 Deck mounted sink mixer 180° foldingspout, aerator, swivel tube spout, flexible hoses M-10 3/8" x 370 mm.
 Mitigeur évier bec rabattable, aérateur, raccords flexibles M-10 3/8" x 370 mm

Ref.	€	📦
 96095	124,00	8

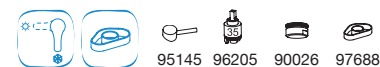

Chef



chef profesional | professional | industriel



PVD
Physical
Vapor
Deposition

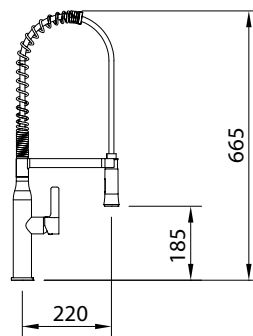

MATT Acabado en mate.
Matt finish. Fini mat

CHEF 5 MATT

FREGADERO

Sink mixer | Mitigeur évier douchette

Mezclador con aireador, caño giratorio, ducha con pulsador para lavavajillas, enlaces de alimentación flexibles M-10 3/8" x 370 mm.

Mixer with aerator, swivel spout, handset and flexible hoses M-10 3/8" x 370 mm.

Évier à bec orientable, ressort de guidage renforcé, douchette avec poussoir pré-lavage. Livré avec raccords flexibles M-10 3/8" x 370 mm

	Ref.	€	📦
	99445	355,00	4

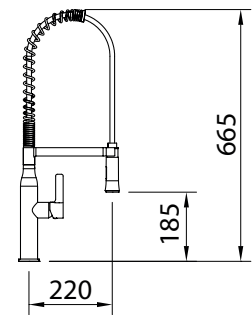
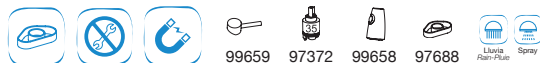

CHEF 5

FREGADERO

Sink mixer | Mitigeur évier douchette

Mezclador con aireador, caño giratorio, ducha con pulsador para lavavajillas, enlaces de alimentación flexibles M-10 3/8" x 370 mm.

Mixer with aerator, swivel spout, handset and flexible hoses M-10 3/8" x 370 mm.

Évier à bec orientable, ressort de guidage renforcé, douchette avec poussoir pré-lavage. Livré avec raccords flexibles M-10 3/8" x 370 mm

	Ref.	€	📦
	99444	317,00	4

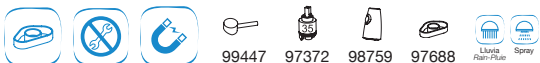

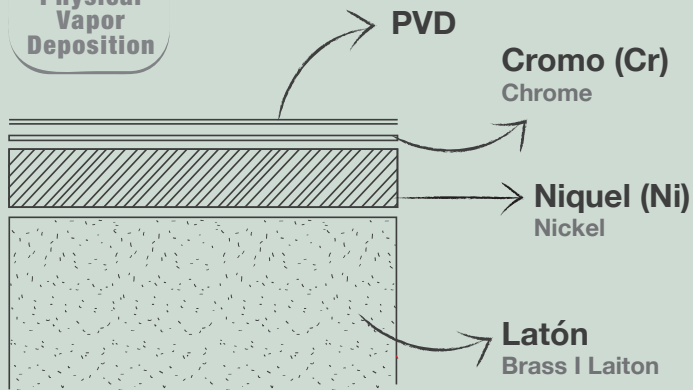

Tecnología PVD. Physical Vapor Deposition

Proceso de recubrimiento donde Nitruro de titanio es vaporizado y transportado al vacío para formar una unión molecular con la pieza a cubrir. El recubrimiento se condensa, formando una película para crear una superficie con **alta resistencia** al desgaste, rayaduras, golpes y corrosión.

Coating process where titanium nitride is vaporized and transported to an empty form with a molecular union to cover the piece. The coating is condensed, forming a film to create a surface with high resistance, postponing wear, scratches, blows and corrosion.

Processus de revêtement de nitrure de titane sous vide (PVD) créant une union moléculaire avec la pièce à couvrir.

Le revêtement se condense, formant une pellicule qui donne à la surface une grande résistance à l'usure, aux rayures, aux coups et à la corrosion.

Para / For / Pour :
Chef 5 MATT, 99445



FREGADERO COLUMNNA LAVAVAJILLAS 750 Sink mixer with swivel spout and dishwashing shower / Mitigeur évier industriel

Fregadero columna lavavajillas, inversor, caño lateral curvo, muelle resistente y ducha de pistola. Flexibles M-10 3/8" x 600 mm.
Sink column, diverter, curver lateral spout, strong spring, dishwashing shower. Flexible hoses M-10 3/8" x 600 mm.
Évier à bec orientable, ressort de guidage renforcé, douchette avec gachette pré-lavage. Livré avec raccords flexibles M-10 3/8" x 600 mm

Ref.	€	📦
750 mm ec1 97101	538,00	4

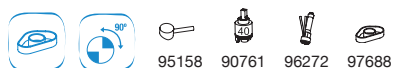

FREGADERO COLUMNNA LAVAVAJILLAS 750 Sink mixer with swivel spout and dishwashing shower / Mitigeur évier industriel

Fregadero columna lavavajillas, caño lateral recto con palanca, muelle resistente, ducha de pistola y flexo 47cm. Flexibles M-10 3/8" x 600 mm.
Sink column, straight lateral spout, diverter, strong spring, dishwashing shower, hose 47cm. Flexible hoses M-10 3/8" x 600 mm.
Évier à bec orientable, ressort de guidage renforcé, douchette avec gachette pré-lavage. Livré avec raccords flexibles M-10 3/8" x 600 mm

Ref.	€	📦
750 mm ec1 96365	538,00	4

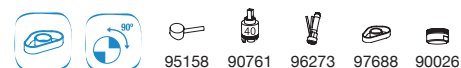

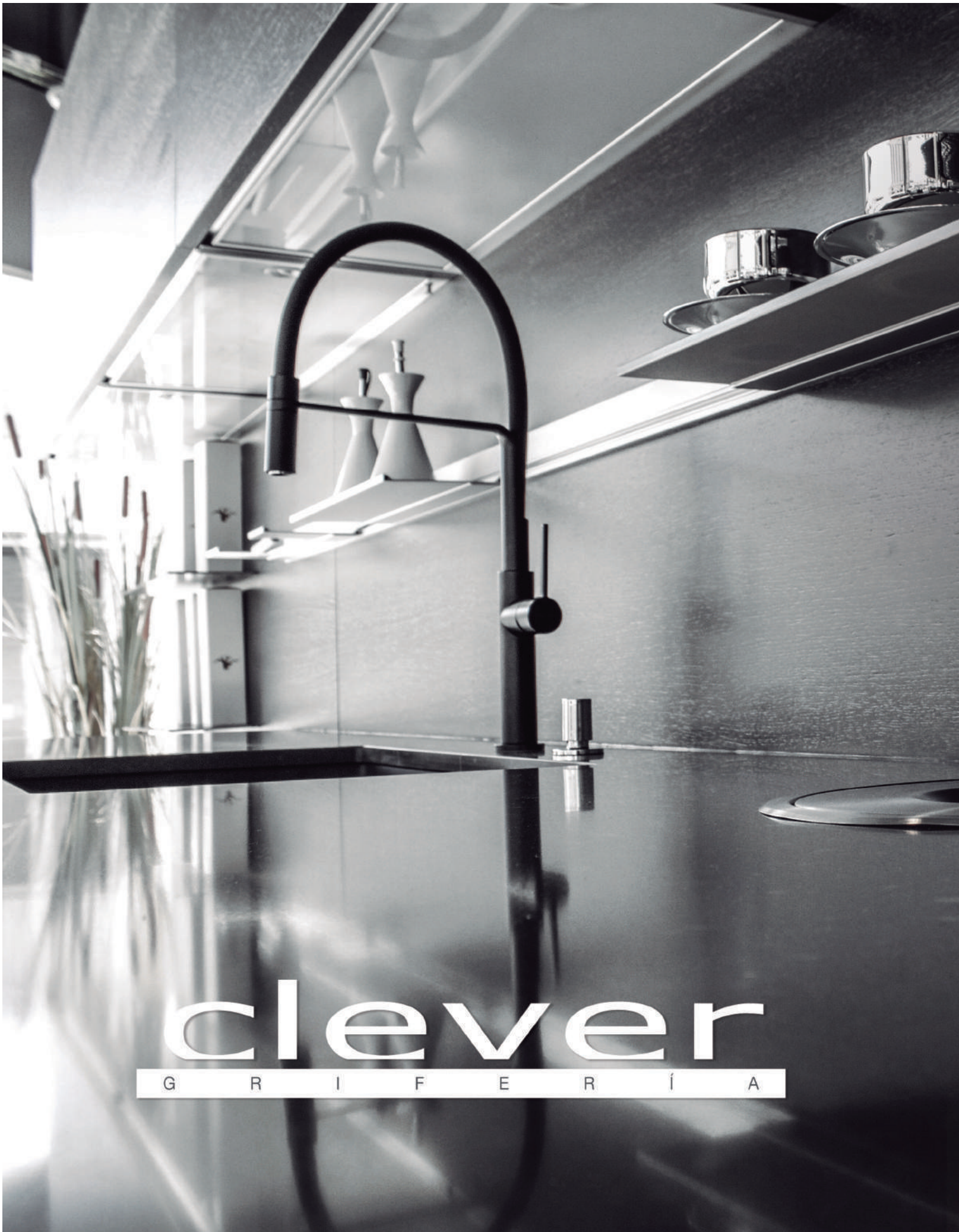

clever

G R I F E R Í A



CHEF SLIM

Moderno y funcional, elige tu estilo

Modern and functional, choose your style · Moderne et fonctionnel, choisissez votre style

Descubre acabados y características en:

Discover the finishes and characteristics in · Découvrez finitions et caractéristiques dans

www.griferiaclever.com/chefslim



Acabado en negro-Cromo.
Black-Chrome finish.
Finition noir - Chrome.

CHEF SLIM NEGRO CROMO
FREGADERO
Sink mixer | Mitigeur évier douchette

Mezclador con aireador, caño giratorio, enlaces de alimentación flexibles M-10 3/8" x 370 mm.
Mixer with aerator, handset and flexible hoses M-10 3/8" x 370 mm.
Évier à bec orientable, ressort de guidage renforcé. Livré avec raccords flexibles M-10 3/8" x 370 mm

	Ref.	€	📦
ec1	60148	228,00	4



Acabado en blanco-Cromo.
White-Chrome finish.
Finition blanc - Chrome.

CHEF SLIM BLANCO CROMO
FREGADERO
Sink mixer | Mitigeur évier douchette

Mezclador con aireador, caño giratorio, enlaces de alimentación flexibles M-10 3/8" x 370 mm.
Mixer with aerator, handset and flexible hoses M-10 3/8" x 370 mm.
Évier à bec orientable, ressort de guidage renforcé. Livré avec raccords flexibles M-10 3/8" x 370 mm

	Ref.	€	📦
ec1	60147	228,00	4

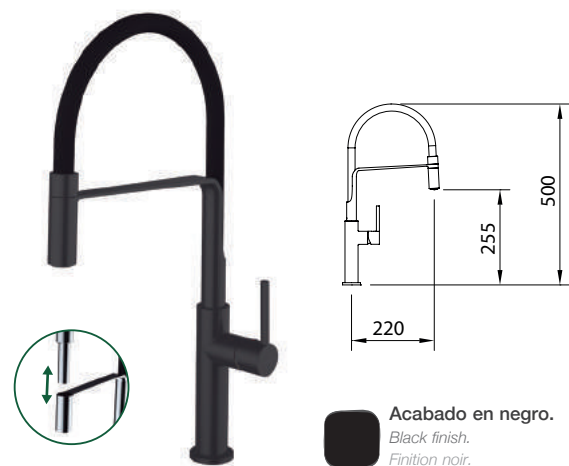

Acabado en negro.
Black finish.
Finition noir.

CHEF SLIM NEGRO
FREGADERO
Sink mixer | Mitigeur évier douchette

Mezclador con aireador, caño giratorio, enlaces de alimentación flexibles M-10 3/8" x 370 mm.
Mixer with aerator, handset and flexible hoses M-10 3/8" x 370 mm.
Évier à bec orientable, ressort de guidage renforcé. Livré avec raccords flexibles M-10 3/8" x 370 mm

	Ref.	€	📦
ec1	60146	212,00	4

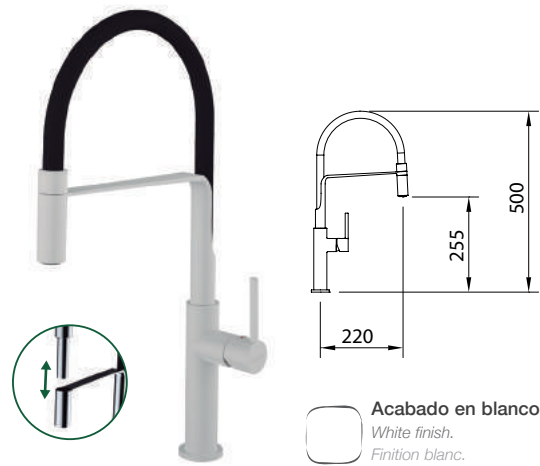

Acabado en blanco.
White finish.
Finition blanc.

CHEF SLIM BLANCO
FREGADERO
Sink mixer | Mitigeur évier douchette

Mezclador con aireador, caño giratorio, enlaces de alimentación flexibles M-10 3/8" x 370 mm.
Mixer with aerator, handset and flexible hoses M-10 3/8" x 370 mm.
Évier à bec orientable, ressort de guidage renforcé. Livré avec raccords flexibles M-10 3/8" x 370 mm

	Ref.	€	📦
ec1	60145	212,00	4



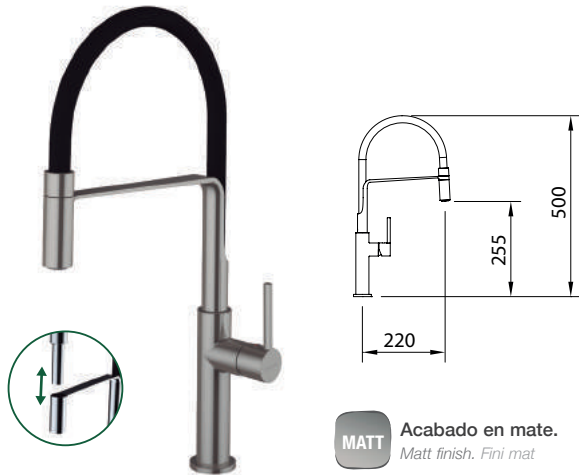

MATT Acabado en mate.
Matt finish. Fini mat

CHEF SLIM MATE
FREGADERO
Sink mixer | Mitigeur évier douchette

Mezclador con aireador, caño giratorio, enlaces de alimentación flexibles M-10 3/8" x 370 mm.
Mixer with aerator, handset and flexible hoses M-10 3/8" x 370 mm.
Évier à bec orientable, ressort de guidage renforcé. Livré avec raccords flexibles M-10 3/8" x 370 mm

	Ref.	€	
ec1	60144	212,00	4



CHEF SLIM
FREGADERO
Sink mixer | Mitigeur évier douchette

Mezclador con aireador, caño giratorio, enlaces de alimentación flexibles M-10 3/8" x 370 mm.
Mixer with aerator, handset and flexible hoses M-10 3/8" x 370 mm.
Évier à bec orientable, ressort de guidage renforcé. Livré avec raccords flexibles M-10 3/8" x 370 mm

	Ref.	€	
ec1	60143	191,00	4



CHEF CARBON
FREGADERO COLUMNA LAVAVAJILLAS
Sink mixer with swivel spout and dishwashing shower | Mitigeur évier industriel

Mezclador con aireador, caño giratorio, ducha con pulsador para lavavajillas, enlaces de alimentación flexibles M-10 3/8" x 370 mm.
Mixer with aerator, swivel spout, handset and flexible hoses M-10 3/8" x 370 mm.
Évier à bec orientable, ressort de guidage renforcé, douchette avec poussoir pré-lavage. Livré avec raccords flexibles M-10 3/8" x 370 mm

	Ref.	€	
ec3	98757	305,00	4

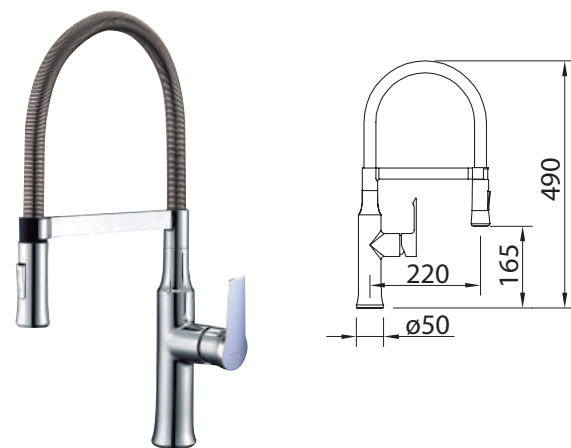

CHEF AGORA
FREGADERO COLUMNA LAVAVAJILLAS
Sink mixer with swivel spout and dishwashing shower | Mitigeur évier industriel

Mezclador con aireador, caño giratorio, ducha con pulsador para lavavajillas, enlaces de alimentación flexibles M-10 3/8" x 370 mm.
Mixer with aerator, swivel spout, handset and flexible hoses M-10 3/8" x 370 mm.
Évier à bec orientable, ressort de guidage renforcé, douchette avec poussoir pré-lavage. Livré avec raccords flexibles M-10 3/8" x 370 mm

	Ref.	€	
ec3	98764	290,00	4

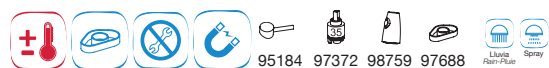

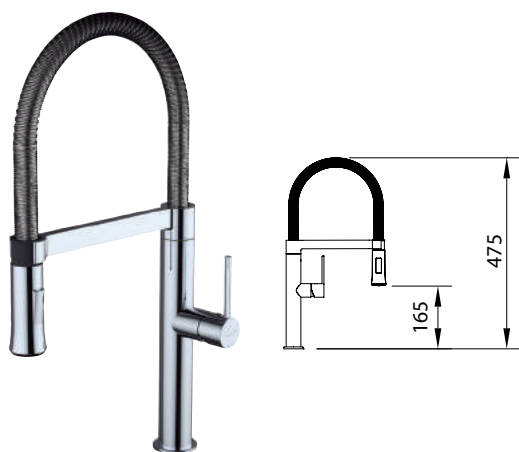

CHEF MAGNET SLIM

FREGADERO

Sink mixer | Mitigeur évier douchette

Mezclador con aireador, caño giratorio, ducha con pulsador para lavavajillas, enlaces de alimentación flexibles M-10 3/8" x 370 mm.

Mixer with aerator, swivel spout, handset and flexible hoses M-10 3/8" x 370 mm.

Évier à bec orientable, ressort de guidage renforcé, douchette avec poussoir pré-lavage. Livré avec raccords flexibles M-10 3/8" x 370 mm

Ref.	€	📦
ec1 60142	269,00	4

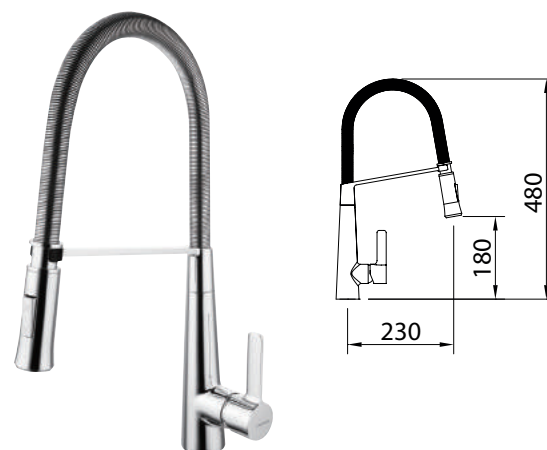

CHEF 4

FREGADERO

Sink mixer | Mitigeur évier douchette

Mezclador con aireador, caño giratorio, ducha con pulsador para lavavajillas, enlaces de alimentación flexibles M-10 3/8" x 420 mm.

Mixer with aerator, swivel spout, handset and flexible hoses M-10 3/8" x 420 mm.

Évier à bec orientable, ressort de guidage renforcé, douchette avec poussoir pré-lavage. Livré avec raccords flexibles M-10 3/8" x 420 mm

Ref.	€	📦
ec3 99443	231,00	4

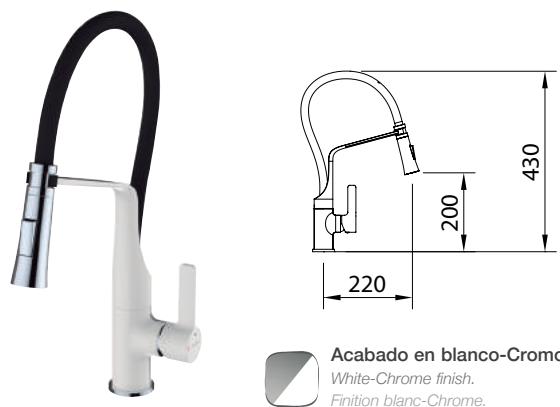

CHEF 6 BLANCO/CROMO

FREGADERO

Sink mixer | Mitigeur évier douchette

Mezclador con aireador, caño giratorio, ducha con pulsador para lavavajillas, enlaces de alimentación flexibles M-10 3/8" x 370 mm.

Mixer with aerator, swivel spout, handset and flexible hoses M-10 3/8" x 370 mm.

Évier à bec orientable, ressort de guidage renforcé, douchette avec poussoir pré-lavage. Livré avec raccords flexibles M-10 3/8" x 370 mm

Ref.	€	📦
ec3 99733	254,00	4

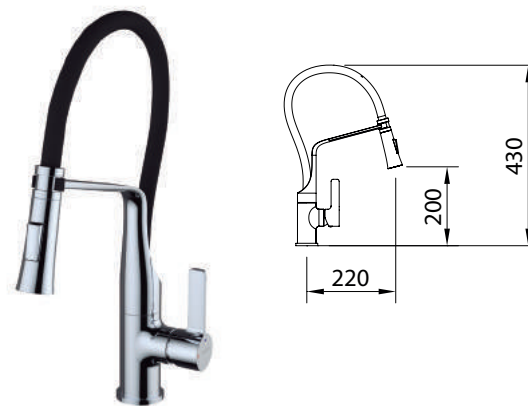
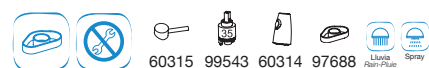

CHEF 6

FREGADERO

Sink mixer | Mitigeur évier douchette

Mezclador con aireador, caño giratorio, ducha con pulsador para lavavajillas, enlaces de alimentación flexibles M-10 3/8" x 370 mm.

Mixer with aerator, swivel spout, handset and flexible hoses M-10 3/8" x 370 mm.

Évier à bec orientable, ressort de guidage renforcé, douchette avec poussoir pré-lavage. Livré avec raccords flexibles M-10 3/8" x 370 mm

Ref.	€	📦
ec3 99735	212,00	4





CHEF 6
Fregadero
Sink Mixer
99733 Mitiger évier douchette

chef extraíble | pull out | extractible



CHEF 3

FREGADERO EXTRAÍBLE

Pull-out sink mixer | Mitigeur évier douchette extractible

Mezclador con aireador, caño giratorio, ducha extraíble con pulsador para lavavajillas, enlaces de alimentación flexibles M-10 3/8" x 370 mm. Mixer with aerator, swivel spout, pull-out handset and flexible hoses M-10 3/8" x 370 mm.

Évier à bec orientable, douchette extractible avec poussoir pré lavage. Livré avec raccords flexibles M-10 3/8" x 370 mm

	Ref.	€	
	99442	263,00	4

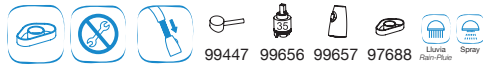

99447 99656 99657 97688

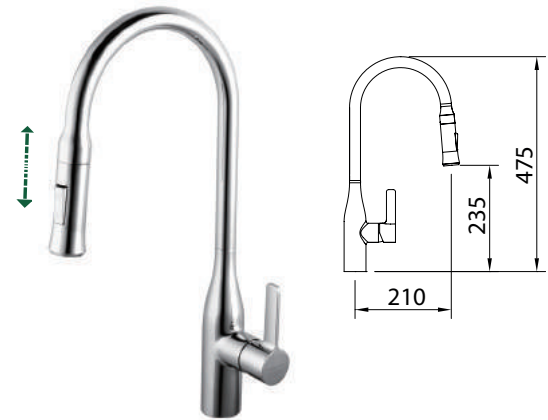

CHEF 2

FREGADERO EXTRAÍBLE

Pull-out sink mixer | Mitigeur évier douchette extractible

Mezclador con aireador, caño giratorio, ducha extraíble con pulsador para lavavajillas, enlaces de alimentación flexibles M-10 3/8" x 370 mm. Mixer with aerator, swivel spout, pull-out handset and flexible hoses M-10 3/8" x 370 mm.

Évier à bec orientable, douchette extractible avec poussoir pré lavage. Livré avec raccords flexibles M-10 3/8" x 370 mm

	Ref.	€	
	99441	199,00	4

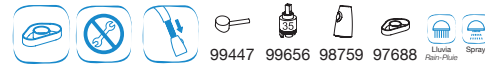

99447 99656 98759 97688

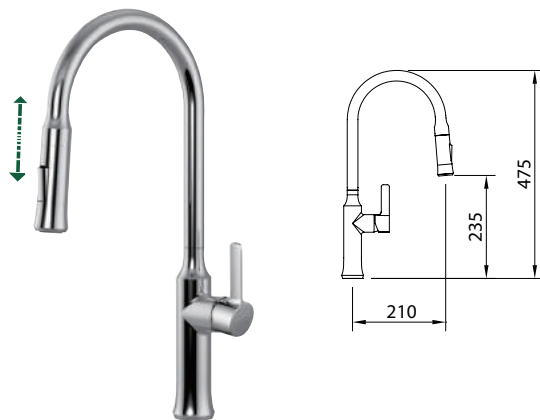

CHEF 1

FREGADERO EXTRAÍBLE

Pull-out sink mixer | Mitigeur évier douchette extractible

Mezclador con aireador, caño giratorio, ducha extraíble con pulsador para lavavajillas, enlaces de alimentación flexibles M-10 3/8" x 370 mm. Mixer with aerator, swivel spout, pull-out handset and flexible hoses M-10 3/8" x 370 mm.

Évier à bec orientable, douchette extractible avec poussoir pré lavage. Livré avec raccords flexibles M-10 3/8" x 370 mm

	Ref.	€	
ec1	99440	183,00	4

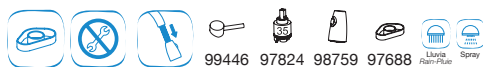

99446 97824 98759 97688



99442

CHEF 3
Fregadero
Sink Mixer
Mitigeur évier douchette

chef básico | basic | simple



INOX Acabado en Inox.
Stainless finish. Fini inox

CURVE - Inox finishing

FREGADERO

Sink mixer | Mitigeur évier douchette

Mezclador con aireador, caño giratorio y flexibles M-10 3/8" x 420 mm.
Mixer with aerator, swivel spout, flexible hoses M-10 3/8" x 420 mm.
Mitigeur évier bec orientable, aérateur, raccords flexibles M-10 3/8" x 420 mm

	Ref.	€	
	ec1 99850	145,00	10

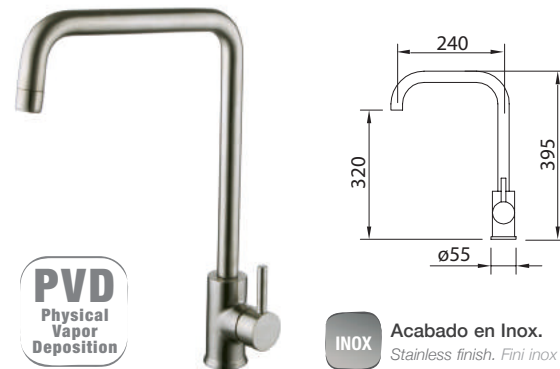

INOX Acabado en Inox.
Stainless finish. Fini inox

RIGHT - Inox finishing

FREGADERO

Sink mixer | Mitigeur évier douchette

Mezclador con aireador, caño giratorio y flexibles M-10 3/8" x 420 mm.
Mixer with aerator, swivel spout, flexible hoses M-10 3/8" x 420 mm.
Mitigeur évier bec orientable, aérateur, raccords flexibles M-10 3/8" x 420 mm

	Ref.	€	
	ec1 99851	145,00	10

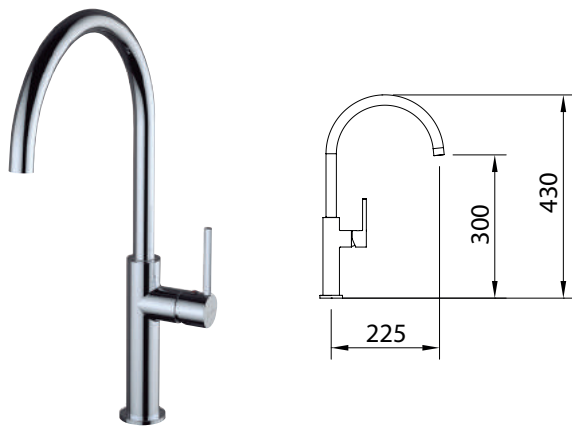

CHEF ESSENTIAL SLIM

FREGADERO

Sink mixer | Mitigeur évier douchette

Mezclador con aireador, caño giratorio, enlaces de alimentación flexibles M-10 3/8" x 370 mm.
Mixer with aerator, swivel spout, flexible hoses M-10 3/8" x 370 mm.
Évier à bec orientable, ressort de guidage renforcé. Livré avec raccords flexibles M-10 3/8" x 370 mm

	Ref.	€	
ec1	60141	160,00	4



Platinum

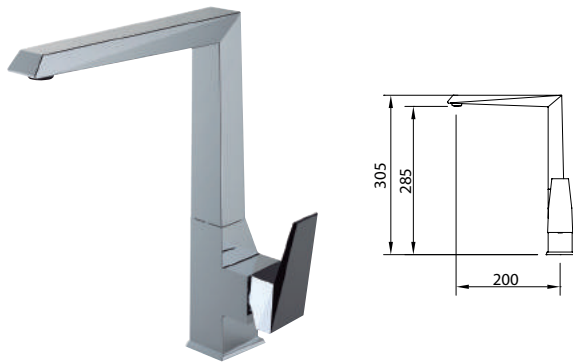

VENTU 285 mm

FREGADERO
Sink mixer | Mitigeur évier

Mezclador con aireador, caño fundido giratorio, flexibles M-10 3/8" x 370 mm.
Mixer with aerator, swivel cast spout, flexible hoses M-10 3/8" x 370 mm.
Mitigeur évier bec orientable, aérateur, raccords flexibles M-10 3/8" x 370 mm



AUDE 275 mm

FREGADERO
Sink mixer | Mitigeur évier

Mezclador con aireador, caño fundido giratorio, flexibles M-10 3/8" x 370 mm.
Mixer with aerator, swivel cast spout, flexible hoses M-10 3/8" x 370 mm.
Mitigeur évier bec orientable, aérateur, raccords flexibles M-10 3/8" x 370 mm.

	Ref.	€	📦
	99438	347,00	8
	99708	351,00	8

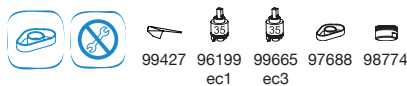

	Ref.	€	📦
	97815	295,00	8



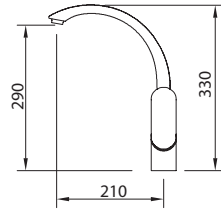

SELENE 290 mm

FREGADERO

Sink mixer | Mitigeur évier

Mezclador con aireador, caño fundido giratorio, flexibles M-10 3/8" x 370 mm.
Mixer with aerator, swivel cast spout, flexible hoses M-10 3/8" x 370 mm.
Mitigeur évier bec orientable, aérateur, raccords flexibles M-10 3/8" x 370 mm

	Ref.	€	📦
	ec1 98014	270,00	8

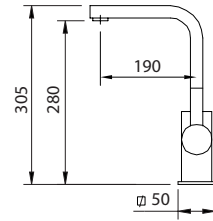

BIMINI 280 mm

FREGADERO

Sink mixer | Mitigeur évier

Mezclador con aireador, caño conformado giratorio, flexibles M-10 3/8" x 370 mm.
Mixer with aerator, swivel tube spout, flexible hoses M-10 3/8" x 370 mm.
Mitigeur évier bec orientable, aérateur, raccords flexibles M-10 3/8" x 370 mm

	Ref.	€	📦
	ec2 97046	233,00	8

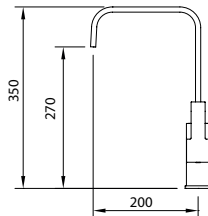
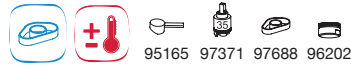

MARINA EVO 270mm

FREGADERO

Sink mixer | Mitigeur évier

Mezclador con aireador, caño conformado giratorio, flexibles M-10 3/8" x 420 mm.
Mixer with aerator, swivel tube spout, flexible hoses M-10 3/8" x 420 mm.
Mitigeur évier bec orientable, aérateur, raccords flexibles M-10 3/8" x 420 mm

	Ref.	€	📦
	ec1 99423	210,00	8
	ec3 99715	214,00	8

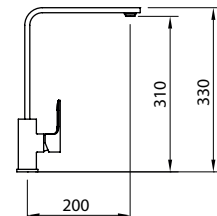
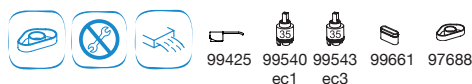

SAONA SLIM 310 mm

FREGADERO

Sink mixer | Mitigeur évier

Mezclador con aireador, caño tubo giratorio, flexibles M-10 3/8" x 370 mm.
Mixer with aerator, swivel spout, flexible hoses M-10 3/8" x 370 mm.
Mitigeur évier bec orientable, aérateur, raccords flexibles M-10 3/8" x 370 mm.

	Ref.	€	📦
	ec1 60128	177,00	8

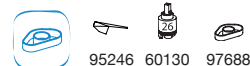

Platinum

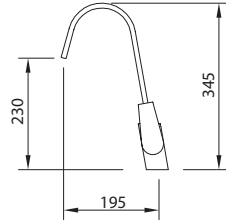

PAULA 230 mm

FREGADERO

Sink mixer | Mitigeur évier douchette

Mezclador con rompeaguas, caño conformado giratorio, flexibles M-10 3/8" x 370 mm.

Mixer with water breaker, swivel tube spout, flexible hoses M-10 3/8" x 370 mm.

Mitigeur évier bec orientable, brise-jet, raccords flexibles M-10 3/8" x 370 mm

	Ref.	€	
 ec1	98201	177,00	8



98216 96199 97688



98201

PAULA
Fregadero
Sink Mixer
Mitigeur évier



97815
AUDE
Fregadero
Sink Mixer
Mitigeur évier



SAONA SLIM
Fregadero
Sink Mixer
Mitiger évier
60128

Styles



monomando vertical | vertical single lever | mitigeur vertical

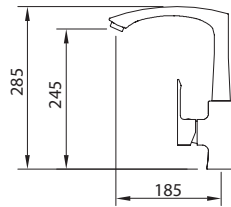

AGORA elegance 245 mm

FREGADERO
Sink mixer | Mitigeur évier

Mezclador con aireador, caño fundido giratorio, flexibles M-10 3/8" x 370 mm.
Mixer with aerator, swivel cast spout, flexible hoses M-10 3/8" x 370 mm.
Mitigeur évier bec orientable, aérateur, raccords flexibles M-10 3/8" x 370 mm

	Ref.	€	📦
	98684	169,00	8

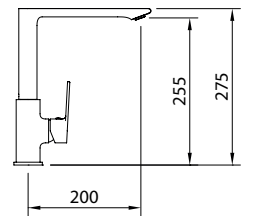

AGORA Xtreme 255 mm

FREGADERO
Sink mixer | Mitigeur évier

Mezclador con aireador, caño fundido giratorio, flexibles M-10 3/8" x 420 mm.
Mixer with aerator, swivel cast spout, flexible hoses M-10 3/8" x 420 mm.
Mitigeur évier bec orientable, aérateur, raccords flexibles M-10 3/8" x 420 mm.

	Ref.	€	📦
	60113	169,00	-



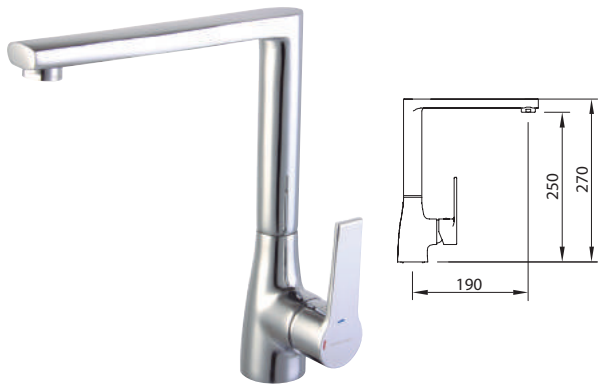



ARTIC xtreme 250 mm

FREGADERO

Sink mixer | Mitigeur évier

Mezclador con aireador, caño fundido giratorio, flexibles M-10 3/8" x 370 mm.
Mixer with aerator, swivel cast spout, flexible hoses M-10 3/8" x 370 mm.
Mitigeur évier bec orientable, aérateur, raccords flexibles M-10 3/8" x 370 mm

	Ref.	€	
 	98694	166,00	8

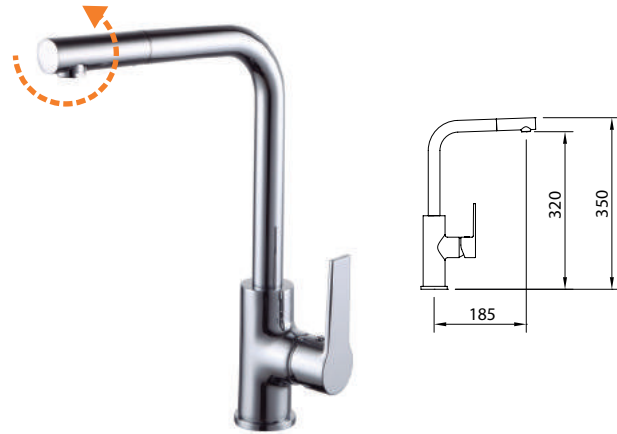



ARTIC xtreme 320 mm

FREGADERO

Sink mixer | Mitigeur évier

Mezclador con aireador, caño giratorio, flexibles M-10 3/8" x 370 mm.
Mixer with aerator, swivel spout, flexible hoses M-10 3/8" x 370 mm.
Mitigeur évier bec orientable, aérateur, raccords flexibles M-10 3/8" x 370 mm

	Ref.	€	
 	99108	155,00	4



ARTIC urban 275 mm

FREGADERO

Sink mixer | Mitigeur évier

Mezclador con aireador, caño conformado giratorio, flexibles M-10 3/8" x 420 mm.
Mixer with aerator, swivel tube spout, flexible hoses M-10 3/8" x 420 mm.
Mitigeur évier bec orientable, aérateur, raccords flexibles M-10 3/8" x 420 mm

	Ref.	€	
 	98107	166,00	5



CAIMAN elegace 230 mm

FREGADERO

Sink mixer | Mitigeur évier

Mezclador con aireador, caño conformado giratorio, flexibles M-10 3/8" x 370 mm.
Mixer with aerator, swivel tube spout, flexible hoses M-10 3/8" x 370 mm.
Mitigeur évier bec orientable, aérateur, raccords flexibles M-10 3/8" x 370 mm

	Ref.	€	
 	97086	168,00	8



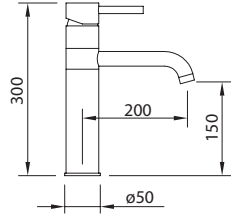

CAIMAN elegance 230 mm

FREGADERO
Sink mixer | Mitigeur évier

Mezclador con caño giratorio con aireador y flexibles M-10 3/8" x 600 mm.
Mixer, aerator swivel spout, flexible hoses M-10 3/8" x 600 mm.
Mitigeur évier bec orientable, aérateur, raccords flexibles M-10 3/8" x 600 mm

	Ref.	€	
	ec1	60161	155,00 20

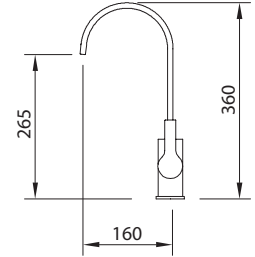
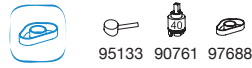

CAIMAN xtreme 265 mm

FREGADERO
Sink mixer | Mitigeur évier

Mezclador con aireador, caño giratorio, flexibles M-10 3/8" x 370 mm.
Mixer with aerator, swivel spout, flexible hoses M-10 3/8" x 370 mm.
Mitigeur évier bec orientable, aérateur, raccords flexibles M-10 3/8" x 370 mm

	Ref.	€	
	ec1	98190	155,00 8

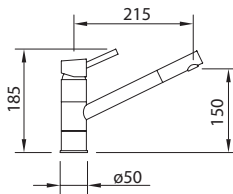

CAIMAN urban 150 mm

FREGADERO
Sink mixer | Mitigeur évier

Mezclador con caño giratorio con aireador y flexibles M-10 3/8" x 370 mm.
Mixer, aerator swivel spout, flexible hoses M-10 3/8" x 370 mm.
Mitigeur évier bec orientable, aérateur, raccords flexibles M-10 3/8" x 370 mm

	Ref.	€	
	ec2	92603	131,00 8





AGORA *elegance*
Fregadero
Sink Mixer
98684 *Mitiger évier*



monomando extraíble | pull out single lever | mitigeur extractible



ARTIC Xtreme 265 mm

FREGADERO EXTRAÍBLE Pull-out sink mixer | Mitigeur évier douche extractible

Mezclador con aireador, caño giratorio, ducha extraíble con pulsador para lavavajillas, enlaces de alimentación flexibles M-10 3/8" x 370 mm.
Mixer with aerator, swivel spout, pull-out handset and flexible hoses M-10 3/8" x 370 mm.
Mitigeur évier bec orientable, aérateur, douche extractible avec poussoir pré-lavage, raccords flexibles M-10 3/8" x 370 mm

	Ref.	€	📦
	98689	197,00	4

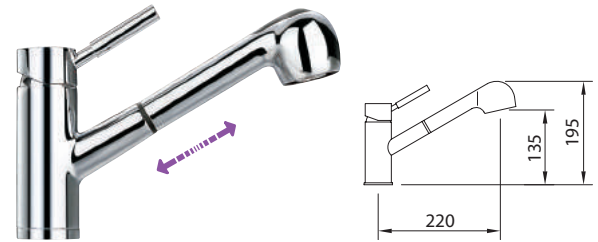

CAIMAN elegance 135 mm

FREGADERO EXTRAÍBLE Pull-out sink mixer | Mitigeur évier douche extractible

Mezclador con aireador, caño giratorio, flexibles M-10 3/8" x 370 mm.
Mixer with aerator, swivel spout, flexible hoses M-10 3/8" x 370 mm.
Mitigeur évier bec orientable, aérateur, raccords flexibles M-10 3/8" x 370 mm

	Ref.	€	📦
	ec1 97069	199,00	8



CAIMAN urban 235 mm

FREGADERO EXTRAÍBLE Pull-out sink mixer | Mitigeur évier douche extractible

Mezclador con aireador, caño giratorio, ducha extraíble con pulsador para lavavajillas, enlaces de alimentación flexibles M-10 3/8" x 370 mm.
Mixer with aerator, swivel spout, pull-out handshower and flexible hoses M-10 3/8" x 370 mm.
Mitigeur évier bec orientable, douche extractible, aérateur, raccords flexibles M-10 3/8" x 370 mm

	Ref.	€	📦
	ec2 97804	219,00	4

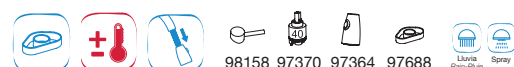

bimando vertical | vertical two handle | mélangeur vertical

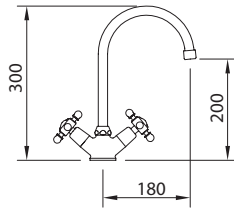

WITH2 antigua 200 mm

FREGADERO
Sink mixer | Mitigeur évier

Mezclador con aireador, caño conformado giratorio, flexibles M-10 3/8" x 370 mm.
Mixer with aerator, swivel tube spout, flexible hoses M-10 3/8" x 370 mm.
Mélangeur évier, bec orientabl, eaérateur, raccords flexibles M-10 3/8" x 370 mm

	Ref.	€	📦
	92049	65,00	8



  
94600 96208 90026

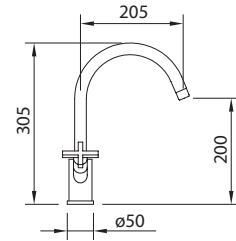



WITH2 morea 200 mm

FREGADERO
Sink mixer | Mitigeur évier

Mezclador con aireador, caño conformado giratorio, flexibles M-10 3/8" x 370 mm.
Mixer with aerator, swivel tube spout, flexible hoses M-10 3/8" x 370 mm.
Mélangeur évier, bec orientabl, eaérateur, raccords flexibles M-10 3/8" x 370 mm

	Ref.	€	📦
	97005	152,00	8



 
95126 97688

Styles Pro



monomando vertical | vertical single lever | mitigeur vertical

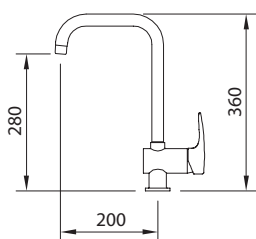

BAHAMA xtreme 280 mm

FREGADERO
Sink mixer | Mitigeur évier

Mezclador con aireador, caño conformado giratorio y flexibles M-10 3/8" x 420 mm.

Mixer, aerator, swivel tube spout, flexible hoses M-10 3/8" x 420 mm.
Mitigeur évier bec orientable, aérateur, raccords flexibles M-10 3/8" x 420 mm

	Ref.	€	📦
	98913	153,00	8
	98179	158,00	8

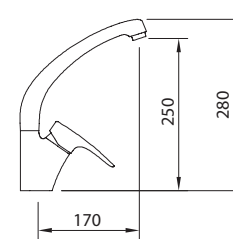
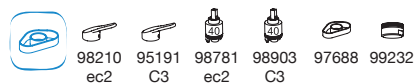

HABANA xtreme 250 mm

FREGADERO
Sink mixer | Mitigeur évier

Mezclador con aireador, caño conformado giratorio y flexibles M-10 3/8" x 370 mm.

Mixer, aerator, swivel tube spout, flexible hoses M-10 3/8" x 370 mm.
Mitigeur évier bec orientable, aérateur, raccords flexibles M-10 3/8" x 370 mm

	Ref.	€	📦
	98917	123,00	8
	98169	125,00	8

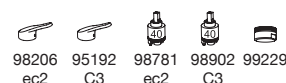



START elegance 260 mm

FREGADERO
Sink mixer | Mitigeur évier

Mezclador con aireador, caño conformado giratorio y flexibles M-10 3/8" x 370 mm.
Mixer, aerator, swivel tube spout, flexible hoses M-10 3/8" x 370 mm.
Mitigeur évier bec orientable, aérateur, raccords flexibles M-10 3/8" x 370 mm.

	Ref.	€	📦
ec1	60183	87,00	8

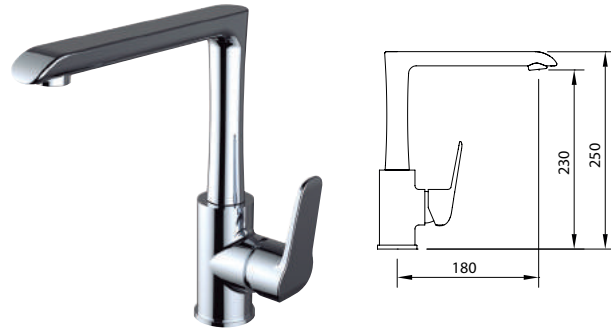

START elegance 230 mm

FREGADERO
Sink mixer | Mitigeur évier

Mezclador con aireador, caño fundido giratorio y flexibles M-10 3/8" x 370 mm.
Mixer, aerator, swivel spout, flexible hoses M-10 3/8" x 370 mm.
Mitigeur évier bec orientable, aérateur, raccords flexibles M-10 3/8" x 370 mm.

	Ref.	€	📦
ec1	60184	106,00	8

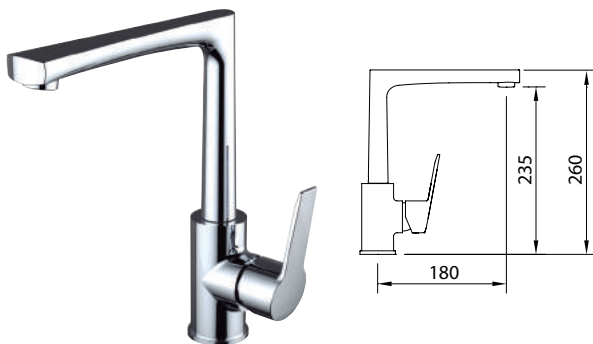

START xtreme 235 mm

FREGADERO
Sink mixer | Mitigeur évier

Mezclador con aireador, caño fundido giratorio, flexibles M-10 3/8" x 370 mm.
Mixer with aerator, swivel cast spout, flexible hoses M-10 3/8" x 370 mm.
Mitigeur évier bec orientable, aérateur, raccords flexibles M-10 3/8" x 370 mm.

	Ref.	€	📦
ec1	60198	100,00	8

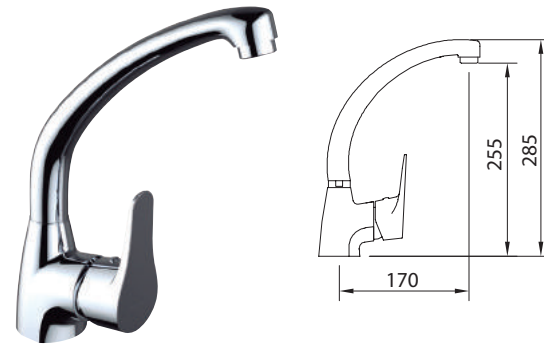

START urban 255 mm

FREGADERO
Sink mixer | Mitigeur évier

Mezclador con aireador, caño conformado giratorio, flexibles M-10 3/8" x 420 mm.
Mixer with aerator, swivel tube spout, flexible hoses M-10 3/8" x 420 mm.
Mitigeur évier bec orientable, aérateur, raccords flexibles M-10 3/8" x 420 mm.

	Ref.	€	📦
ec2	98921	88,00	12
ec3	98615	92,00	12

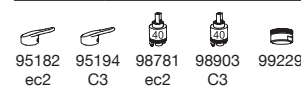



START Urban 245 mm

FREGADERO
Sink mixer | Mitigeur évier

Mezclador con aireador, caño fundido giratorio, flexibles M-10 3/8" x 420 mm.
Mixer with aerator, swivel cast spout, flexible hoses M-10 3/8" x 420 mm.
Mitigeur évier bec orientable, aérateur, raccords flexibles M-10 3/8" x 420 mm

	Ref.	€	📦
	98922	100,00	12
	98614	102,00	12

95194 C3	95182 ec2	98781 ec2	98903 C3	99229

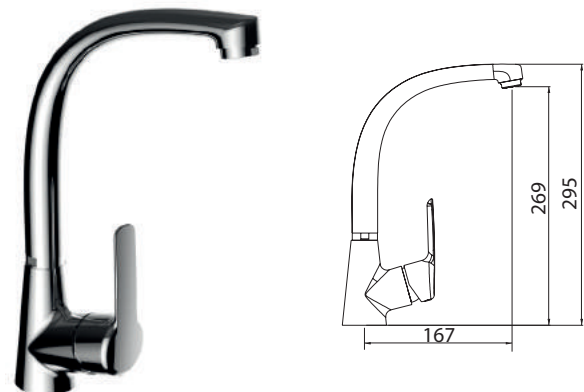

PANAM EVO elegance 269 mm

FREGADERO
Sink mixer | Mitigeur évier

Mezclador con aireador, caño conformado giratorio, flexibles M-10 3/8" x 370 mm.
Mixer with aerator, swivel tube spout, flexible hoses M-10 3/8" x 370 mm.
Mitigeur évier bec orientable, aérateur, raccords flexibles M-10 3/8" x 370 mm

	Ref.	€	📦
	60548	75,00	-

95253	99817	99229

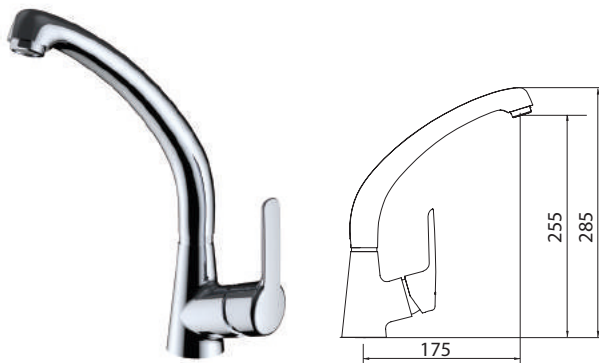

PANAM EVO elegance 255 mm

FREGADERO
Sink mixer | Mitigeur évier

Mezclador con aireador, caño fundido giratorio y enlaces de alimentación flexibles M-10 3/8" x 370 mm.
Mixer with aerator, swivel cast spout and connections M10-3/8" x 370 mm.
Mitigeur évier bec orientable, aérateur, raccords flexibles M-10 3/8" x 370 mm

	Ref.	€	📦
	60594	81,00	-

95253	99817	99229

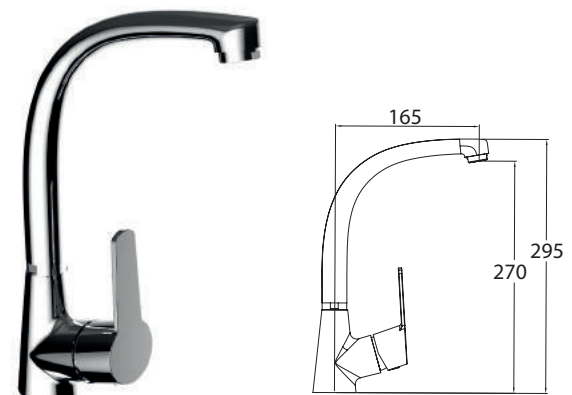

PANAM EVO xtreme 270 mm

FREGADERO
Sink mixer | Mitigeur évier

Mezclador con aireador, caño conformado giratorio, flexibles M-10 3/8" x 370 mm.
Mixer with aerator, swivel tube spout, flexible hoses M-10 3/8" x 370 mm.
Mitigeur évier bec orientable, aérateur, raccords flexibles M-10 3/8" x 370 mm

	Ref.	€	📦
	60533	75,00	-

95255	99817	99229

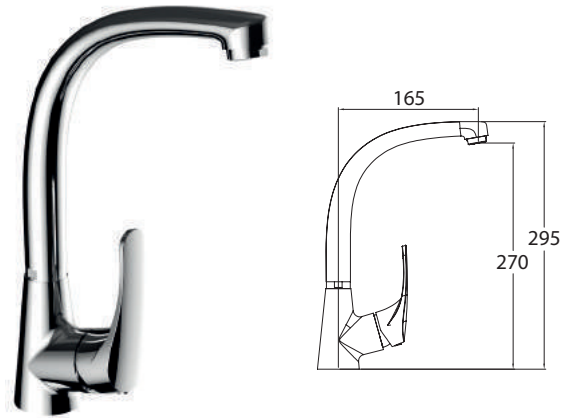

PANAM EVO Urban 270 mm







FREGADERO
Sink mixer | Mitigeur évier

Mezclador con aireador, caño conformado giratorio, flexibles M-10 3/8" x 370 mm.

Mixer with aerator, swivel tube spout, flexible hoses M-10 3/8" x 370 mm.

Mitigeur évier bec orientable, aérateur, raccords flexibles M-10 3/8" x 370 mm

	Ref.	€	
   	60513	75,00	-

95257 99817 99229

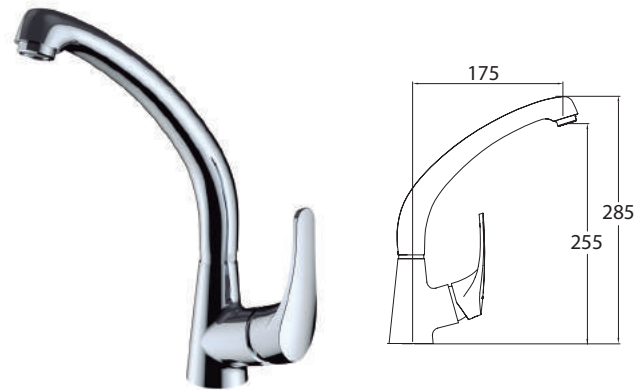

PANAM EVO Urban 255 mm



FREGADERO
Sink mixer | Mitigeur évier

Mezclador con aireador, caño fundido giratorio y enlaces de alimentación flexibles M-10 3/8" x 370 mm.

Mixer with aerator, swivel cast spout and connections M10-3/8" x 370 mm.

Mitigeur évier bec orientable, aérateur, raccords flexibles M-10 3/8" x 370 mm

	Ref.	€	
   	60592	81,00	-

95257 99817 99229



60513
PANAM EVO Urban
Fregadero
Sink Mixer
Mitigeur évier



PANAM Urban 250 mm

FREGADERO
Sink mixer | Mitigeur évier

Mezclador con aireador, caño conformado giratorio y flexibles M-10 3/8" x 370 mm
Mixer with aerator, swivel tube spout, flexible hoses M-10 3/8" x 370 mm.
Mitigeur évier bec orientable, aérateur, raccords flexibles M-10 3/8" x 370 mm

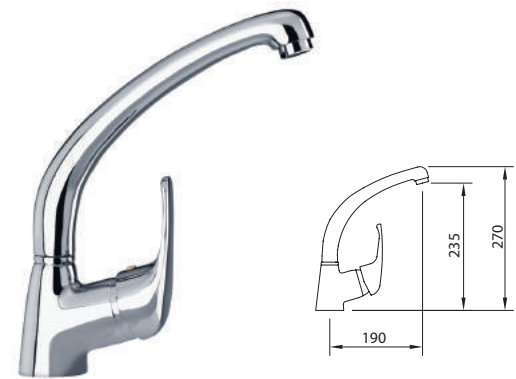

	Ref.	€	📦
  	92350	75,00	12



PANAM Urban 235 mm

FREGADERO
Sink mixer | Mitigeur évier

Mezclador con aireador, caño fundido giratorio, flexibles M-10 3/8" x 370 mm.
Mixer with aerator, swivel cast spout, flexible hoses M-10 3/8" x 370 mm.
Mitigeur évier bec orientable, aérateur, raccords flexibles M-10 3/8" x 370 mm



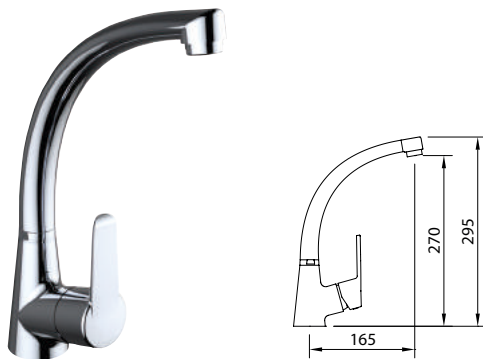
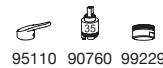





	Ref.	€	📦
  	92351	81,00	12



S12 elegance 270 mm

FREGADERO
Sink mixer | Mitigeur évier

Mezclador con aireador, caño conformado giratorio, flexibles M-10 3/8" x 370 mm.
Mixer with aerator, swivel tube spout, flexible hoses M-10 3/8" x 370 mm.
Mitigeur évier bec orientable, aérateur, raccords flexibles M-10 3/8" x 370 mm



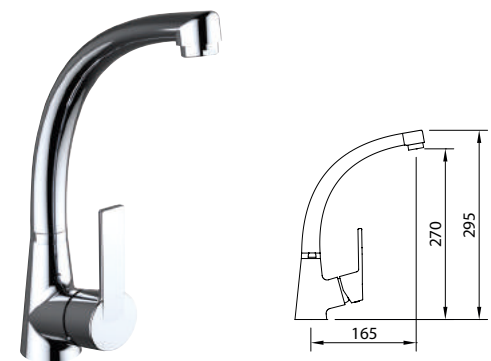
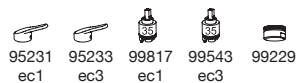





	Ref.	€	📦
  	99848	75,00	12
    	99340	79,00	12



S12 Xtreme 270 mm

FREGADERO
Sink mixer | Mitigeur évier

Mezclador con aireador, caño conformado giratorio, flexibles M-10 3/8" x 370 mm.
Mixer with aerator, swivel tube spout, flexible hoses M-10 3/8" x 370 mm.
Mitigeur évier bec orientable, aérateur, raccords flexibles M-10 3/8" x 370 mm

	Ref.	€	📦
  	99833	75,00	12
    	99265	79,00	12

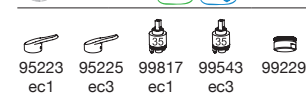

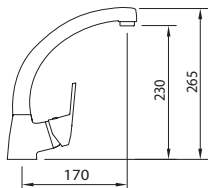

S12 urban 230 mm

FREGADERO
Sink mixer | Mitigeur évier

Mezclador con aireador, caño conformado giratorio, flexibles M-10 3/8" x 370 mm.

Mixer with aerator, swivel tube spout, flexible hoses M-10 3/8" x 370 mm.

Mitigeur évier bec orientable, aérateur, raccords flexibles M-10 3/8" x 370 mm

	Ref.	€	📦
	98334	75,00	12
	98803	79,00	12

- 95175
ec1
- 95196
C3
- 98237
ec1
- 98903
C3
- 99229

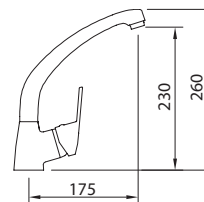

S12 urban 230 mm

FREGADERO
Sink mixer | Mitigeur évier

Mezclador con aireador, caño fundido giratorio y enlaces de alimentación flexibles M-10 3/8" x 370 mm.

Mixer with aerator, swivel cast spout and connections M10-3/8" x 370 mm.

Mitigeur évier bec orientable, aérateur, raccords flexibles M-10 3/8" x 370 mm

	Ref.	€	📦
	98344	81,00	12
	98804	85,00	12

- 95175
ec1
- 95196
C3
- 98237
ec1
- 98903
C3
- 99229



98921
START urban
Fregadero
Sink Mixer
Mitigeur évier

monomando horizontal | horizontal single lever | mitigeur horizontal

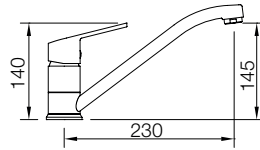

BAHAMA Xtreme 145 mm

FREGADERO HORIZONTAL
Horizontal sink mixer | Mitigeur évier

Mezclador con aireador, caño giratorio y flexibles M-10 3/8" x 370 mm.
Mixer, aerator, swivel spout flexible hoses M-10 3/8" x 370 mm.
Mitigeur évier bec orientable, aérateur, raccords flexibles M-10 3/8" x 370 mm

	Ref.	€	📦
	99944	87,00	8
	99945	91,00	8

98209
 98870
 98902
 60155
 97688
 C1 C3

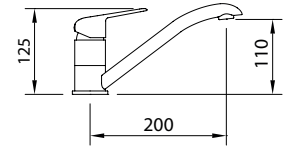

START elegance 110 mm

FREGADERO HORIZONTAL
Horizontal sink mixer | Mitigeur évier

Mezclador con aireador, caño giratorio y flexibles M-10 3/8" x 370 mm.
Sink mixer with aerator, swivel spout, flexible hoses M-10 3/8" x 370 mm.
Mitigeur évier bec orientable, aérateur, raccords flexibles M-10 3/8" x 370 mm

	Ref.	€	📦
	99386	87,00	12
	99388	91,00	12

95234
 95236
 99540
 99542
 99229
 ec1 ec3 ec1 ec3

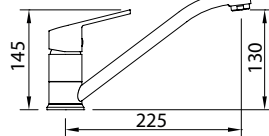

PANAM EVO urban 130 mm

FREGADERO HORIZONTAL
Horizontal sink mixer | Mitigeur évier

Mezclador con aireador, caño giratorio y flexibles M-10 3/8" x 370 mm.
Sink mixer with aerator, swivel spout and flexible hoses M10-3/8" x 370 mm.
Mitigeur évier bec orientable, aérateur, raccords flexibles M-10 3/8" x 370 mm

	Ref.	€	📦
	60516	67,00	-

95256
 99226
 90025

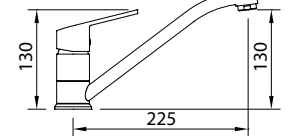

S12 urban 130 mm

FREGADERO HORIZONTAL
Horizontal sink mixer | Mitigeur évier

Mezclador con aireador, caño giratorio y flexibles M-10 3/8" x 370 mm.
Sink mixer, aerator, swivel spout, flexible hoses M-10 3/8" x 370 mm.
Mitigeur évier bec orientable, aérateur, raccords flexibles M-10 3/8" x 370 mm

	Ref.	€	📦
	99221	67,00	12
	99222	69,00	12
	99223	71,00	12

99224
 99225
 99226
 99227
 99228
 90025
 ec1-ec2 ec3 ec1 ec2 ec3

monomando extraíble | pull out single lever | mitigeur extractible

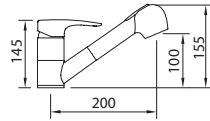

BAHAMA xtreme 100 mm

FREGADERO EXTRAÍBLE

Pull-out sink mixer | Mitigeur évier avec douchette extractible

Mezclador con aireador, caño giratorio, ducha extraíble con pulsador para lavavajillas, enlaces de alimentación flexibles M-10 3/8" x 370 mm. Mixer with aerator, swivel spout, pull-out handshower and flexible hoses M-10 3/8" x 370 mm.

Mitigeur évier bec orientable, douchette extractible, aérateur, raccords flexibles M-10 3/8" x 370 mm

	Ref.	€	📦	Incluye Includes Inklus
	98180	164,00	8	2 Functions 90794 96117

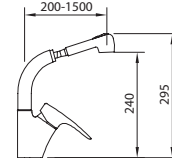

HABANA xtreme 240 mm

FREGADERO EXTRAÍBLE

Pull-out sink mixer | Mitigeur évier avec douchette extractible

Mezclador con aireador, caño giratorio, ducha extraíble con pulsador para lavavajillas, enlaces de alimentación flexibles M-10 3/8" x 370 mm. Mixer with aerator, swivel spout, pull-out handset and flexible hoses M-10 3/8" x 370 mm.

Mitigeur évier bec orientable, douchette extractible, aérateur, raccords flexibles M-10 3/8" x 370 mm

	Ref.	€	📦	Incluye Includes Inklus
	98552	126,00	12	2 Functions 90794 96117



monomando mural | wall mounted single lever | mitigeur mural

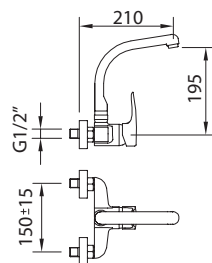

HABANA xtreme 195 mm

FREGADERO MURAL

Wall mounted single lever sink mixer | Mitigeur évier mural

Mezclador con aireador, caño superior conformado giratorio.

Mixer, aerator, upper swivel tube spout

Mitigeur évier mural, bec orientable façonné, aérateur

	Ref.	€	📦
	98549	94,00	12

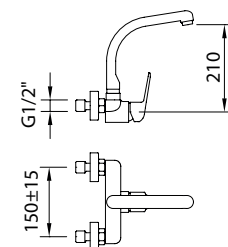

START elegance 210 mm

FREGADERO MURAL

Wall mounted single lever sink mixer | Mitigeur évier mural

Mezclador mural con aireador, caño conformado giratorio superior.

Wall mounted mixer with aerator, upper swivel tube spout.

Mitigeur évier mural, bec orientable façonné, aérateur

	Ref.	€	📦
	99389	96,00	12



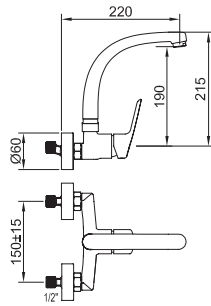

PANAM EVO *elegance* 190 mm



FREGADERO MURAL
Wall mounted single lever sink mixer
Mitigeur évier mural

Mezclador mural con aireador, caño conformado giratorio superior.
 Wall mounted mixer with aerator, upper swivel tube spout.
 Mitigeur évier mural, bec orientable façonné, aérateur

	Ref.	€	
	60549	91,00	-

- 95253
- 99817
- 99229

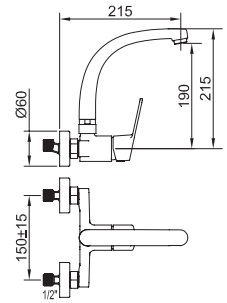

PANAM EVO *Xtreme* 190 mm



FREGADERO MURAL
Wall mounted single lever sink mixer
Mitigeur évier mural

Mezclador mural con aireador, caño conformado giratorio superior.
 Wall mounted mixer with aerator, upper swivel tube spout.
 Mitigeur évier mural, bec orientable façonné, aérateur

	Ref.	€	
	60534	91,00	-

- 95255
- 99817
- 99229

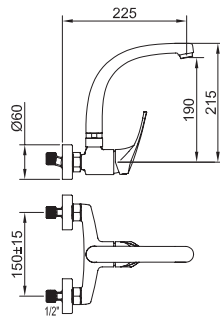

PANAM EVO *urban* 190 mm



FREGADERO MURAL
Wall mounted single lever sink mixer
Mitigeur évier mural

Mezclador mural con aireador, caño conformado giratorio superior.
 Wall mounted mixer with aerator, upper swivel tube spout.
 Mitigeur évier mural, bec orientable façonné, aérateur

	Ref.	€	
	60514	91,00	-

- 95257
- 99817
- 99230

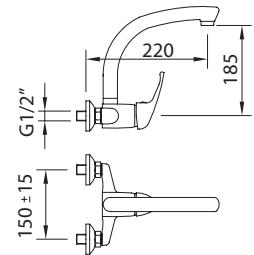

PANAM *urban* 185 mm

FREGADERO MURAL
Wall mounted single lever sink mixer | Mitigeur évier mural

Mezclador con aireador, caño conformado giratorio.
 Mixer with aerator, swivel tube spout.
 Mitigeur évier mural, bec orientable façonné, aérateur

	Ref.	€	
	96067	91,00	12

- 95110
- 90760
- 99230

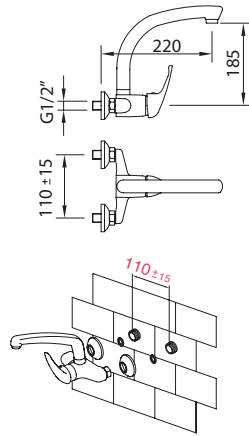

PANAM Urban 185 mm

FREGADERO MURAL 110

Wall mounted single lever sink mixer | Mitigeur évier mural

Mezclador con aireador, caño conformado giratorio.
Mixer with aerator, swivel tube spout.
Mitigeur évier mural, bec orientable façonné, aérateur

	Ref.	€	📦
	ec1 98500	91,00	12

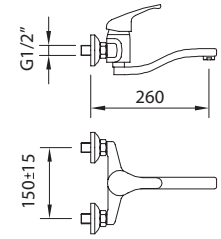

PANAM Urban

FREGADERO MURAL

Wall mounted sink mixer | Mitigeur évier mural

Mezclador mural con aireador y caño giratorio inferior.
Wall mounted mixer operated with aerator, flower swivel spout
Mitigeur évier mural, bec orientable façonné, aérateur

	Ref.	€	📦
	ec1 97805	87,00	8

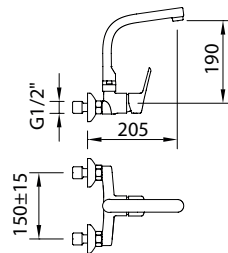

S12 elegance 190 mm

FREGADERO MURAL

Wall mounted single lever sink mixer
Mitigeur évier mural

Mezclador mural con aireador, caño conformado giratorio superior.
Wall mounted mixer with aerator, upper swivel tube spout.
Mitigeur évier mural, bec orientable façonné, aérateur

	Ref.	€	📦
	ec1 99849	91,00	12

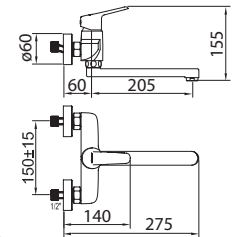

S12 elegance

FREGADERO MURAL

Wall mounted sink mixer
Mitigeur évier mural

Mezclador mural con aireador, caño giratorio inferior.
Wall mounted mixer operated with aerator, flower swivel spout.
Mitigeur évier mural, bec orientable façonné, aérateur

	Ref.	€	📦
	ec1 60726	87,00	-

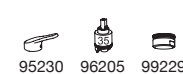

NEW

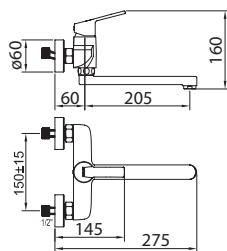

S12 Xtreme

FREGADERO MURAL

Wall mounted sink mixer | Mitigeur évier mural

Mezclador mural con aireador, caño giratorio inferior.
Wall mounted mixer operated with aerator, flower swivel spout.
Mitigeur évier mural, bec orientable façonné, aérateur

	Ref.	€	
	ec1 60727	87,00	-
	95222		
	96205		
	99229		

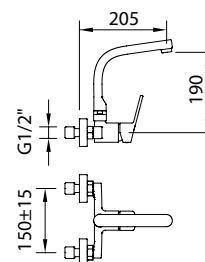

S12 Xtreme 190 mm

FREGADERO MURAL

Wall mounted single lever sink mixer | Mitigeur évier mural

Mezclador mural con aireador, caño conformado giratorio superior.
Wall mounted sink mixer with aerator, upper swivel tube spout.
Mitigeur évier mural, bec orientable façonné, aérateur

	Ref.	€	
	ec1 99834	91,00	12
	95223		
	99817		
	99229		

NEW

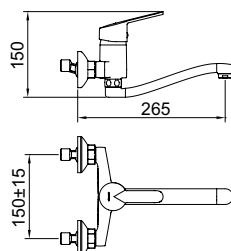

S12 Urban

FREGADERO MURAL

Wall mounted sink mixer | Mitigeur évier mural

Mezclador mural con aireador, caño giratorio inferior.
Wall mounted mixer operated with aerator, flower swivel spout.
Mitigeur évier mural, bec orientable façonné, aérateur

	Ref.	€	
	ec1 60725	87,00	-
	95174		
	98237		
	90025		

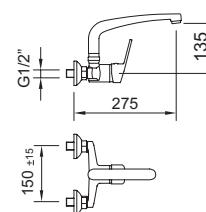

S12 Urban 135 mm

FREGADERO MURAL CAÑO LARGO

Long spout wall mounted sink mixer | Mitigeur évier mural

Mezclador mural con aireador, caño conformado giratorio superior.
Wall mounted sink mixer with aerator, upper swivel tube spout.
Mitigeur évier mural, bec orientable façonné, aérateur

	Ref.	€	
	ec1 98329	94,00	12
	95175		
	98237		
	90025		

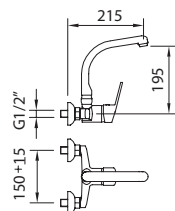

S12 Urban 195 mm

FREGADERO MURAL

Wall mounted sink mixer | Mitigeur évier mural

Mezclador mural con aireador, caño conformado giratorio superior.
Wall mounted sink mixer with aerator, upper swivel tube spout.
Mitigeur évier mural, bec orientable façonné, aérateur

	Ref.	€	
	ec1 98335	91,00	12
	95175		
	98237		
	90025		

monomando 1 agua | 1 water single lever | robinet 1 eau

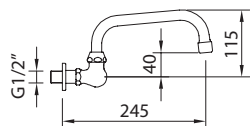

S12 Urban

GRIFO SIMPLE MURAL

Wall mounted single tap | Robinet simple mural

Grifo simple mural con aireador y caño conformado giratorio.
Wall mounted single tap aerator and swivel tube spout.
Robinet évier bec orientable, aérateur

Ref.	€	📦
98450	32,00	12



90026 96208

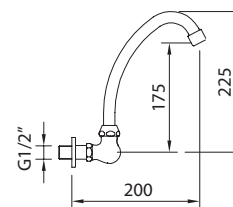

S12 Urban

GRIFO SIMPLE MURAL

Wall mounted single tap | Robinet simple mural

Grifo simple mural con aireador y caño conformado giratorio.
Wall mounted single mixer, aerator and swivel tube spout.
Robinet évier bec orientable, aérateur

Ref.	€	📦
98501	32,00	12



90026 96208

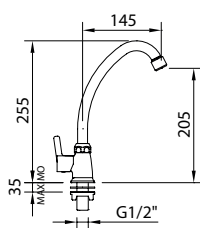

S12 Urban

GRIFO SIMPLE REPISA

Single tap | Robinet simple

Con caño conformado giratorio con aireador.
Swivel tube spout, aerator.
Robinet lavabo, aérateur, 1/2"

Ref.	€	📦
98992	32,00	24



90026 96208

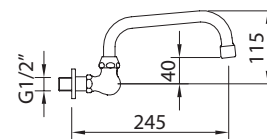

PANAM Urban

GRIFO SIMPLE MURAL

Wall mounted single tap | Robinet simple mural

Grifo de pared con aireador y caño conformado giratorio.
Deck mounted single faucet aerator and swivel tube spout.
Robinet évier bec orientable, aérateur.

Ref.	€	📦
98459	32,00	12



90026 96208

bimando vertical | two handle vertical | mélangeur vertical

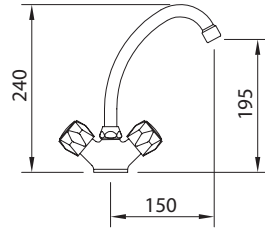

WITH2 guayama 195 mm

FREGADERO

Sink mixer | Mélangeur évier

Mezclador con aireador, caño conformado giratorio, flexibles M-10 3/8" x 370 mm.

Mixer with aerator, swivel tube spout, flexible hoses M-10 3/8" x 370 mm.

Mélangeur évier, bec orientabl, eaérateur, raccords flexibles M-10 3/8" x 370 mm

	Ref.	€	📦
	96088	50,00	12



96232

96233

96208

90026

bimando mural | wall mounted two handle | mélangeur mural

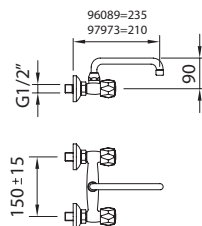

WITH2 guayama 90 mm

FREGADERO MURAL 150MM

Wall mounted single lever sink mixer 150 mm | Mélangeur évier mural 150 mm

Mezclador con aireador, caño conformado giratorio.

Mixer with aerator, swivel tube spout.

Mélangeur évier mural, bec orientable, aérateur

	Ref.	€	📦
235 mm caño, spout, bec	96089	59,00	8
210 mm caño, spout, bec	97973	59,00	8



96232

96233

96208

90026

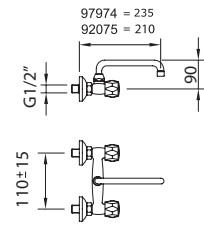

WITH2 guayama 90 mm

FREGADERO MURAL 110MM

Wall mounted single lever sink mixer 110 mm | Mélangeur évier mural 110 mm

Mezclador con aireador, caño conformado giratorio.

Mixer with aerator, swivel tube spout.

Mélangeur évier mural, bec orientable, aérateur

	Ref.	€	📦
235 mm caño, spout, bec	97974	45,00	12
210 mm caño, spout, bec	92075	45,00	12



96232

96233

94459

90026

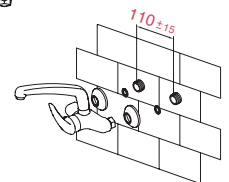

grifo 1 agua | 1 water | robinet 1 eau

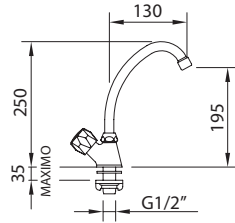

WITH2 guayama 195 mm

GRIFO SIMPLE REPISA

Single tap | Robinet simple

Grifo con aireador y caño conformado giratorio.
Deck mounted single faucet aerator and swivel tube spout.
Robinet évier bec orientable, aérateur

	Ref.	€	📦
	96462	31,00	8



96232 96208 90026

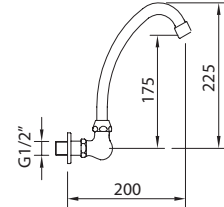

WITH2 guayama 175 mm

GRIFO SIMPLE MURAL

Wall mounted single tap | Robinet simple mural

Grifo de pared con aireador y caño conformado giratorio.
Deck mounted single faucet aerator and swivel tube spout.
Robinet évier bec orientable, aérateur

	Ref.	€	📦
	96754	31,00	12



96232 96208 90026

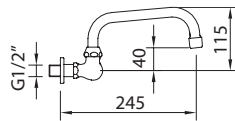

WITH2 guayama 40 mm

GRIFO SIMPLE MURAL

Wall mounted single tap | Robinet simple mural

Grifo de pared con aireador y caño conformado giratorio.
Deck mounted single faucet aerator and swivel tube spout.
Robinet évier bec orientable, aérateur

	Ref.	€	📦
	96767	31,00	12



96232 96208 90026

Gerontológico Medical lever P.M.R.



gerontológico vertical | vertical medical lever | manette médicale vertical

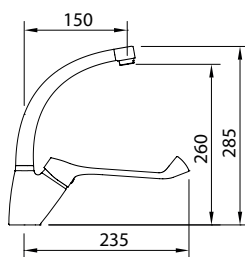

S12 Urban

FREGADERO CON MANETA GERONTOLÓGICA

Sink mixer with medical lever | Mitigeur évier avec manette médicale

Fregadero con maneta gerontológica con aireador y caño conformado giratorio y flexibles M-10 3/8" x 370 mm con palanca gerontológica.

Sink mixer with medical lever with mixer, swivel tube spout, with medical lever operated with aerator, flexible hoses M-10 3/8" x 370 mm.

Mitigeur évier, manette médicale, bec orientable façonné, aérateur, raccords flexibles M-10 3/8" x 370 mm

	Ref.	€	
	99215	85,00	8



99217 98237 90025

gerontológico mural | wall mounted medical lever | manette médicale mural



PANAM urban

FREGADERO CON MANETA GERONTOLÓGICA Wall mounted sink mixer with medical lever | Mitigeur évier mural, manette médicale

Mezclador mural con aireador, con palanca gerontológica y caño giratorio inferior.
Wall mounted mixer with medical lever operated with aerator, flower swivel spout
Mitigeur évier mural, manette médicale, bec orientable façonné, aérateur

	Ref.	€	
	ec1 97975	95,00	12



S12 urban

FREGADERO MURAL CON MANETA GERONTOLÓGICA Wall sink mixer with medical lever | Mitigeur évier mural avec manette médicale

Fregadero con maneta gerontológica mural con aireador, caño giratorio inferior.
Sink mixer with medical lever with mixer, with wall mounted mixer, medical lever operated with aerator, lower swivel spout.
Mitigeur évier mural, manette médicale, bec orientable façonné, aérateur

	Ref.	€	
	99216	99,00	12

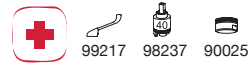

accesorios cocina | kitchen accessories | accessoires de cuisine



FLEXIBLE NYLON Nylon flexible | Nylon flexible

	Ref.	€	
Para/To/Pour Artic 96755	98006	11,00	1
Para/To/Pour Artic 98689	99173	16,00	1



FLEXIBLE Flexible | Flexible

Tubo flexible para ducha extraíble lavavajillas. Inox
Flexible for pull-out mixer. Stainless steel
Flexible pour évier avec douchette extractible

	Ref.	€	
	96117	14,00	1
Para/To/Pour Artic 97101, 96771, 96365, 96175, 96176	96464	11,00	1





HIDROCLEVER



iclever basin
iclever 2
iclever 4
 208



ikansas
 218



Rociadores
 Shower heads
 Pommes de douche
 220



Brazos rociador
 Shower arms
 Bras de douche
 225



Conjuntos de ducha
 Shower kits
 Ensembles de douche
 226



Barras de ducha
 Sliding bars
 Barres de douche
 228

Personaliza tu baño

Customize your bathroom
Personnalisez votre salle de bain



Caños
Bath spouts
Becs
230



Jets hidromasaje
Body jets
Jets
230



Teléfonos de ducha
Handsets
Douchettes
231



Soportes
Wall brackets
Supports
235



Flexibles
Flexibles
Flexibles
236



Salidas flexo
Wall outlets
Sorties Flexible
237



iKansas, sistema doméstico oculto

Hidden domestic System / Système de robinets d'arrêt cachés



Ver página / See page / voir la page

218

iclever, la mejor solución empotrada combinada con la tecnología más avanzada.

The best concealed solution with the latest technology
La mieux solution boîte avec la dernière technologie.

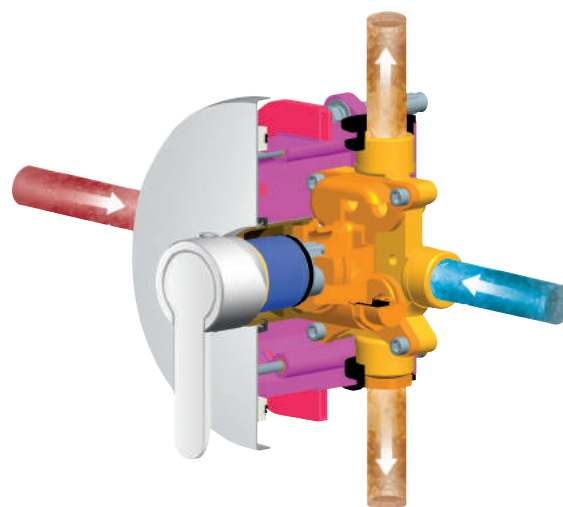

Ver página / See page / voir la page

208

iclever

En todas sus combinaciones.
All combinations | Dans toutes les combinaisons.

iClever es el revolucionario sistema de instalación de 1 sola pieza (caja empotrada) que permite obtener todas las funciones de la ducha o baño ducha que desees. Tú eliges las funciones que quieras para tu baño, luego la caja iclever y por último ya puedes escoger el modelo de grifería de nuestra colección que más te guste. En tres simples pasos todos son ventajas!

iClever is the revolutionary 1 piece installation system (concealed box) that allows you to obtain all shower or bath shower functions. You choose the features you want for your bathroom, then the box and finally our iclever, afterwards you are ready to choose the faucet you like. In three simple steps, all the advantages!

iClever est un système révolutionnaire d'installation d'une seule pièce (boîte encastrée) qui permet d'obtenir toutes les fonctions de la douche ou du bain-douche que vous désirez. Vous choisissez les fonctions que vous souhaitez pour votre bain, puis la boîte iClever et enfin vous pouvez choisir le modèle de robinetterie de votre préférence dans notre collection. Trois simples étapes qui ne présentent que des avantages!

Ventajas iclever iclever advantages / iclever avantages

- ✓ Fácil y rápido de montar y de desmontar.
Easy and quick to assemble and disassemble.
Facile et rapide à monter et à démonter.
- ✓ Evita desperfectos en la superficie cromada de la grifería.
Avoid any damage on the chrome surface.
Évite d'endommager la surface de chrome du robinet.
- ✓ Sistema flexible: con una base se obtienen múltiples configuraciones.
Flexible system: with only a base, we obtain multiple configurations.
Système flexible avec une seule base pour de multiples configurations
- ✓ Gran seguridad y durabilidad.
High level of reliability and durability.
Grande sécurité et durabilité
- ✓ Renueva tu grifería sin obras.
Renew your faucet without works.
Permet de modifier votre robinetterie sans travaux.
- ✓ La instalación permite ser testeada antes del montaje completo.
The installation can be tested before to complete it.
L'installation peut être testée avant l'assemblage complet.

Todas nuestras soluciones All our solutions Toutes nos solutions

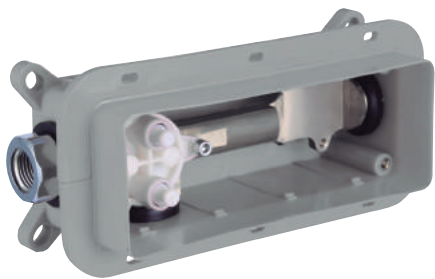

iclever basin*

Para lavabo empotrado.
For the concealed basin mixer.
Lavabo encastré



iclever 2*

Para ducha empotrada 1 y 2 vías.
For the concealed bath-shower
1 and 2 outlet diverter.
Pour douche encastrée 1 et 2
voies.

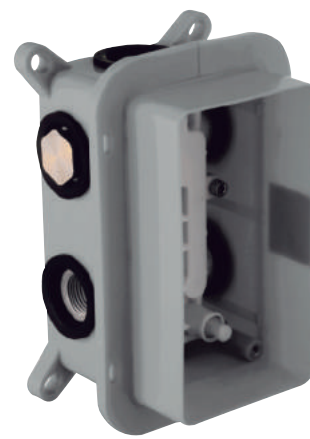

iclever 4*

Para ducha empotrada 3 y 4 vías.
Para termostático empotrado 2 y 3 vías.
For the concealed shower 3 and 4 outlet diverter.
For the concealed thermostatic 2 and 3 outlet
diverter.
Pour douche encastrée 3 et 4 voies.
Pour thermostatique encastré 2 et 3 voies.

* El color de la caja puede estar sujeto a modificaciones / The box color may be subject to change / La couleur de la boîte peut être soumise à des changements

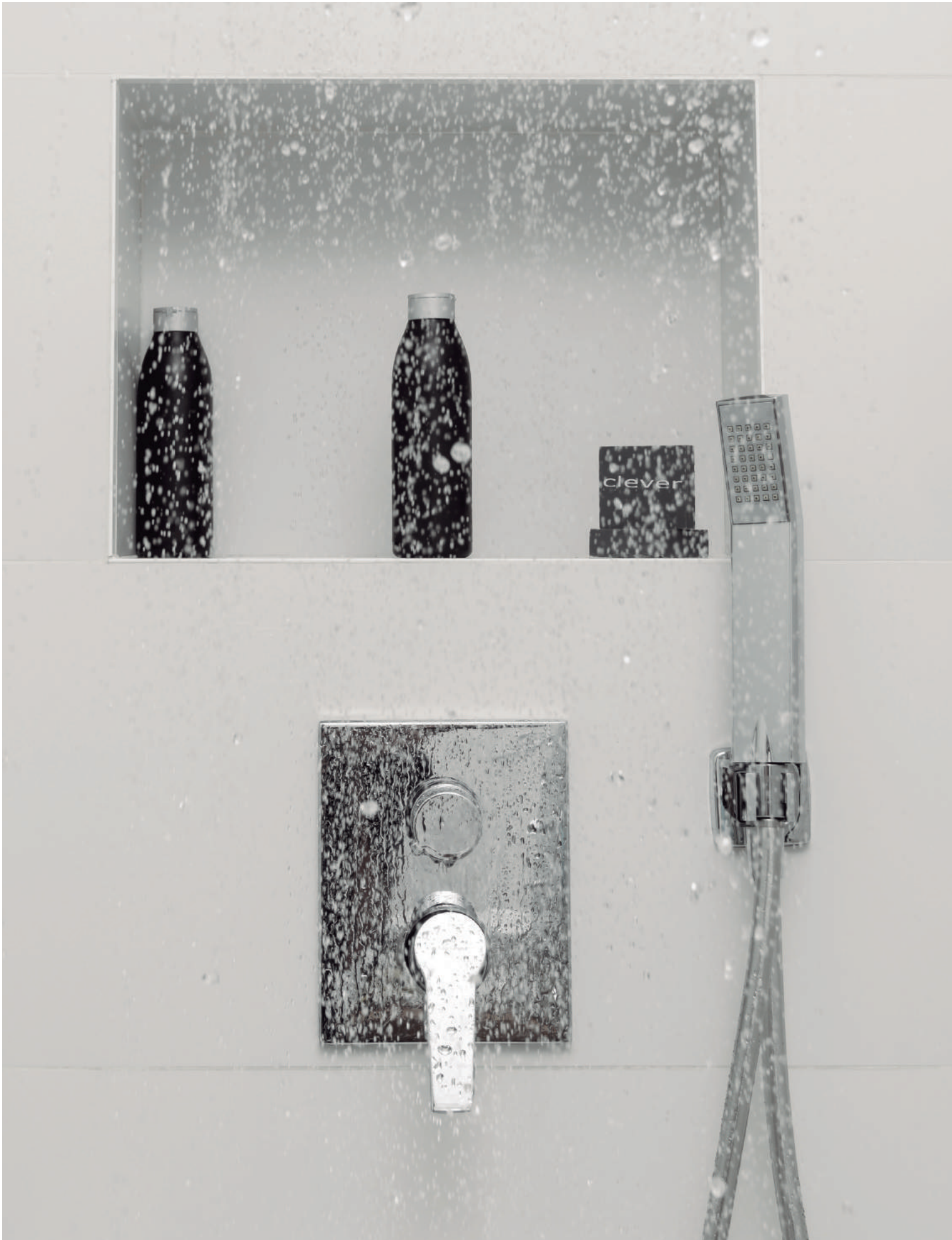

iclever En todas sus combinaciones. All combinations | Dans toutes les combinaisons.

LAVABO EMPOTRADO. Concealed basin mixer | Lavabo encastré

iclever basin

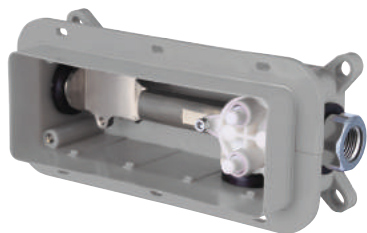

Ref.	€	📦
98703	124,00	6



Instrucciones instalación
Instructions installation
Instructions d'installation

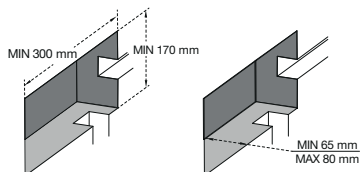

Lavabo empotrado / Concealed basin mixer / Lavabo encastré



Instrucciones lavabo empotrado
Instructions concealed basin mixer
Instructions lavabo encastré

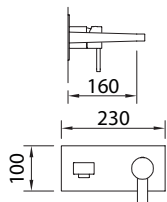

VENTU

99718	216,00	📦	6
-------	--------	---	---



BIMINI

98706	141,00	📦	6
-------	--------	---	---



PAULA

98708	141,00	📦	6
-------	--------	---	---



AGORA *elegance*

98709	141,00	📦	6
-------	--------	---	---



ARTIC *xtreme*

98710	141,00	📦	6
-------	--------	---	---



CAIMAN *elegance*

98707	141,00	📦	6
-------	--------	---	---



* El precio no incluye la caja empotrada / Price does not include the concealed box
Le prix ne comprend pas la boîte d'encastrement



99718
Lavabo empotrado
Concealed Basin Mixer
Lavabo encastré



iclever En todas sus combinaciones.

All combinations | Dans toutes les combinaisons.

DUCHA EMPOTRADA 1 VIA.

Concealed bath-shower 1 outlet diverter | Douche encastré 1 voie

iclever 2



Ref.	€	📦
98711	82,00	6



Instrucciones instalación
Instructions installation
Instructions d'installation

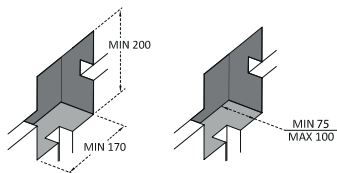

Ducha empotrada
Concealed bath-shower / Douche encastré



Instrucciones lavabo empotrado
Instructions concealed basin mixer
Instructions lavabo encastré

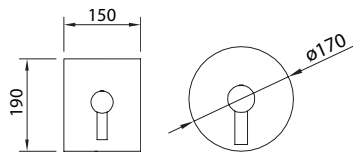

VENTU

99719	135,00	📦 6
-------	--------	-----



BIMINI

98714	98,00	📦 6
-------	-------	-----



PAULA

98716	98,00	📦 6
-------	-------	-----



AGORA *elegance*

98720	98,00	📦 6
-------	-------	-----



AGORA *xtreme*

60746	98,00	📦 -
-------	-------	-----



* El precio no incluye la caja empotrada / Price does not include the concealed box
Le prix ne comprend pas la boîte d'encastrement



ARTIC xtreme

98721	98,00		6
-------	-------	--	---



95185 97371



CAIMAN urban

98719	98,00		6
-------	-------	--	---



96223 97371



ARTIC urban

98717	98,00		6
-------	-------	--	---



98240 97371



BAHAMA xtreme

98723	98,00		6
-------	-------	--	---



98209 90760



CAIMAN elegance

98715	98,00		6
-------	-------	--	---



95132 97371



PANAM urban

98724	93,00		6
-------	-------	--	---



95012 90760



CAIMAN xtreme

98718	98,00		6
-------	-------	--	---



98212 97371



S12 urban

98725	93,00		6
-------	-------	--	---



95174 90760

Combinaciones con iclever 2. 1 vía
 Combinations iclever 2. 1 outlet diverter / Combinaisons iclever 2. 1 voie

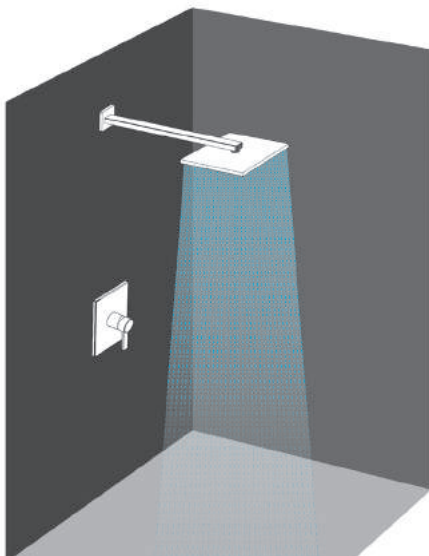

Ducha de empotrar con rociador
 Concealed shower with Shower head
 Douche encastrée avec pomme de douche



Ducha de empotrar con teléfono
 Concealed shower with handset
 Douche encastrée avec douchette



Baño de empotrar con caño
 Concealed shower with bath spout
 Mitigeur bain encastré

iclever En todas sus combinaciones.

All combinations | Dans toutes les combinaisons.

DUCHA EMPOTRADA 2 VIAS.

Concealed bath-shower 2 outlet diverter | Douche encastré 2 voies

iclever 2



Ref.	€	📦
98711	82,00	6



Instrucciones instalación
Instructions installation
Instructions d'installation

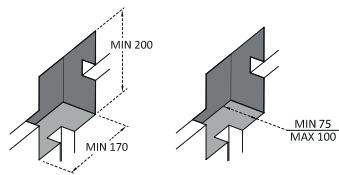

Ducha empotrada
Concealed bath-shower / Douche encastré



Instrucciones lavabo empotrado
Instructions concealed basin mixer
Instructions lavabo encastré

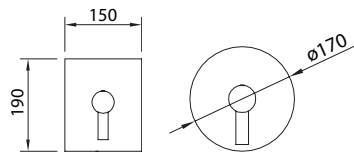

VENTU

Ref.	€	📦
99720	156,00	6

ec2 99426 97371



BIMINI

Ref.	€	📦
98729	124,00	6

ec2 95146 97371



PAULA

Ref.	€	📦
98731	124,00	6

ec2 98215 97371



AGORA *elegance*

Ref.	€	📦
98735	124,00	6

ec2 95183 97371



AGORA *xtreme*

Ref.	€	📦
60747	124,00	-

ec2 95242 97371



* El precio no incluye la caja empotrada / Price does not include the concealed box
Le prix ne comprend pas la boîte d'encastrement



ARTIC xtreme
 98736 124,00 6



CAIMAN urban
 98734 124,00 6

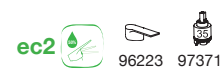

ARTIC urban
 98732 124,00 6



BAHAMA xtreme
 98738 124,00 6



CAIMAN elegancE
 98730 124,00 6



PANAM urban
 98739 110,00 6



CAIMAN xtreme
 98733 124,00 6



S12 urban
 98740 110,00 6



Combinaciones con iclever 2. 2 vías
 Combinations iclever 2. 2 outlet diverter / Combinaisons iclever 2. 2 voies

Ducha / Shower / Douche

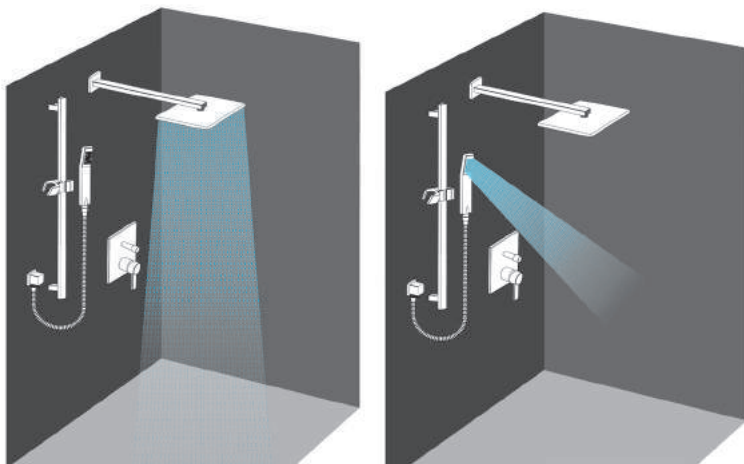

Ducha de empotrar con inversor. Rociador y teléfono.
 Concealed shower with diverter. Shower head and handset.
 Douche encastrée avec inverseur. Pomme de douche et douchette.

Baño - Ducha / Bath-shower / Bain-douche

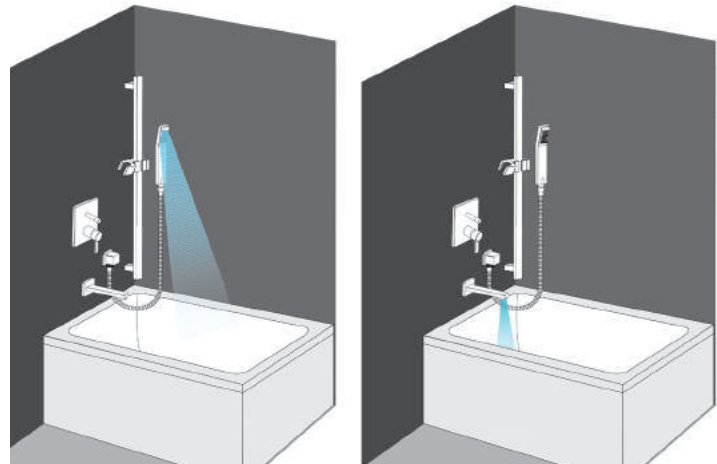

Baño-Ducha de empotrar con inversor. Teléfono y caño.
 Concealed bath-shower with diverter. Handset and spout.
 Bain-Douche encastrée avec inverseur. Pomme de douche ou douchette et bec.

iclever En todas sus combinaciones.

All combinations | Dans toutes les combinaisons.

DUCHA EMPOTRADA 3-4 VIAS.

Concealed bath-shower 3-4 outlet diverter | Douche encastré 3-4 voies

iclever 4



Ref.	€	📦
98742	113,00	6



Instrucciones instalación
Instructions installation
Instructions d'installation

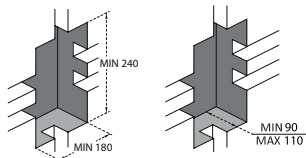

Ducha empotrada
Concealed bath-shower / Douche encastré



Instrucciones ducha empotrada
Instructions concealed basin mixer
Instructions lavabo encastré

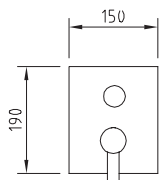

BIMINI

98745	175,00	📦 6
-------	--------	-----



CAIMAN *elegance*

98746	175,00	📦 6
-------	--------	-----



PAULA

98747	175,00	📦 6
-------	--------	-----



AGORA *elegance*

98748	175,00	📦 6
-------	--------	-----



ARTIC *xtreme*

98749	175,00	📦 6
-------	--------	-----



AGORA *xtreme*

60748	175,00	📦 -
-------	--------	-----



* El precio no incluye la caja empotrada / Price does not include the concealed box
Le prix ne comprend pas la boîte d'encastrement



NINE urban

60745 227,00



TERMOSTÁTICO / Thermostatic / Thermostatique
MÁX. 3 VÍAS / Max. 3 outlet diverter / Max. 3 voies



NINE urban

98750 227,00



TERMOSTÁTICO / Thermostatic / Thermostatique
MÁX. 3 VÍAS / Max. 3 outlet diverter / Max. 3 voies



Combinaciones con iclever 4. 3 vías
Combinations iclever 4. 3 outlet diverter / Combinaisons iclever 4. 3 voies

Ducha / Shower / Douche

Ducha de empotrar con inversor. Rociador, Teléfono o Jets.
Concealed shower with diverter. Shower head , handset or body jets.
Douche encastrée avec dérivateur. Pomme de douche, set de douche ou jets.

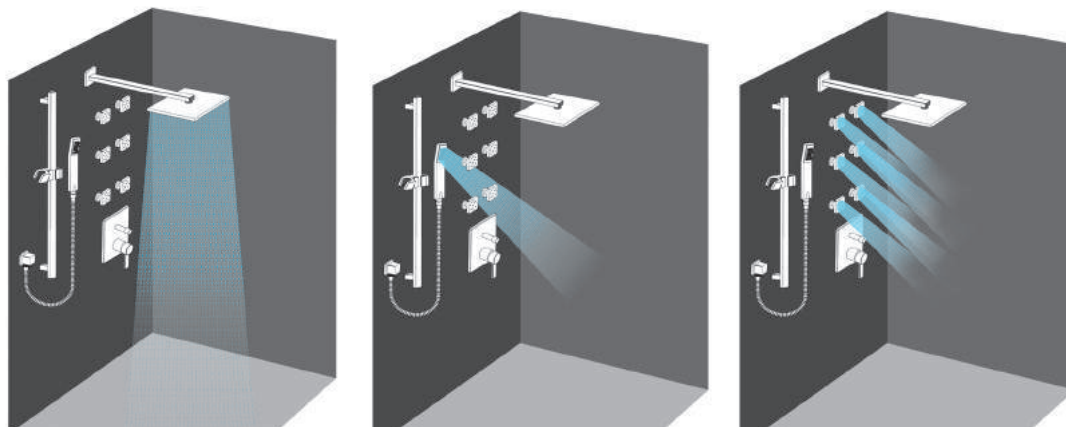

Baño - Ducha / Bath-shower / Bain-douche

Baño-Ducha de empotrar. Rociador, teléfono, jets o caño.
Concealed bath-shower with diverter. Shower head , handset, body jets or bath spout.
Bain-Douche encastré. Pomme de douche, set de douche, jets et bec.

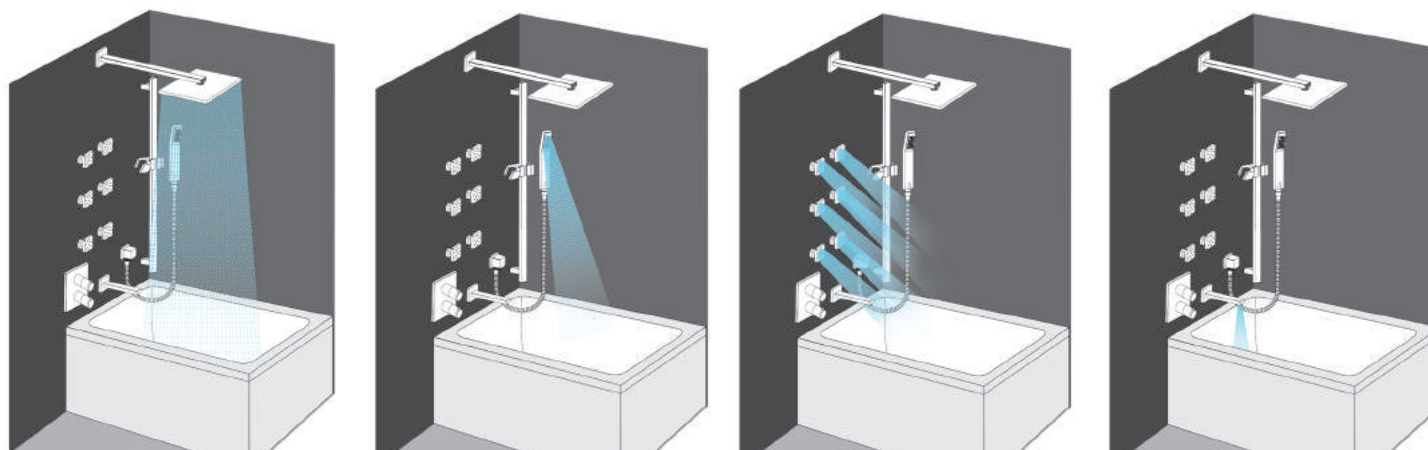

ikansas Sistema de cierre doméstico oculto.

Hidden domestic System | Système de robinets d'arrêt cachés

NEW

iKansas, para la distribución del agua y el cierre de los sistemas sanitarios de la casa (agua fría y caliente). Se puede instalar en cualquier habitación sin comprometer la estética. Nos permite sustituir las válvulas de paso instaladas sin necesidad de romper la pared gracias a su sistema registrable de entrada frontal.

iKansas, for the water distribution and to close the sanitary home systems (cold and hot water) you can install it in any room without affecting the appearance. It allows to substitute the valves installed without any need to break the tiles due to the frontal inlet system

Ikansas, pour la distribution de l'eau et la fermeture du réseau de votre maison (eau froide et eau chaude) Peut être installé dans tout type d'espace sans en altérer l'esthétique. Ikansas vous permet de remplacer les robinets d'arrêt sans devoir détériorer les murs, grâce à son système d'entrée frontale enregistrable.



MODELO DE UTILIDAD
MODEL OF UTILITY
MODÈLE DE UTILITY

Ventajas y características ikansas

ikansas advantages and characteristics / Ikansas avantages et caractéristiques :

- ✓ Utiliza dos monturas de cierre cerámico con un giro suave de 90°.
It uses two ceramic headworks to close with a soft 90° turn
Equipé de deux têtes céramiques ¼ de tour
- ✓ 4 salidas rosca 3/4".
4 outlets with ¾" thread.
4 connexions mâle ¾".
- ✓ iKansas Box tiene poca profundidad: 75 mm. Está diseñado para ser utilizado en todo tipo de paredes o estructuras de yeso.
iKansas Box is Slim: 75mm. it is designed for being used in any wall or plaster structures.
L'iKansas Box est étroit: 75 mm. Il est conçu pour être installé dans tout type de mur (placo inclus).
- ✓ Es de fácil y rápida instalación
It is a fast and easy installation
Installation facile et rapide.
- ✓ Disponible para PN 10 y Temp. máxima 90°C.
Available for PN10 and maximum temperature 90°C
Supporte une PN de 10 bars. Température max. 90°C
- ✓ La tapa del ikansas ha sido diseñada en dos colores (blanco y plata) para integrarse fácilmente en cualquier entorno.
The iKansas cover has been designed in two colours (white and silver) to be integrated easily in any environment.
Le couvercle de l'ikansas est disponible en deux coloris (blanc et argenté).





CAJA iKANSAS con tapa color blanco
ikansas box with white cover
ikansas boîte avec couvercle blanc

Ref.	€*	
31226	77,00	1



CAJA iKANSAS con tapa color plata
ikansas box with silver cover
ikansas boîte avec couvercle argenté

Ref.	€*	
31227	84,00	1

RECAMBIOS *Spare parts / Pièces de rechange*



MONTURA 3/4"
Ceramic Headwork / Monture

Ref.	€*	
31223	9,00	1

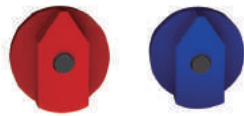

VOLANTE
Handle / Volant

	Ref.	€*	
●	31224	1,70	1
●	31225	1,70	1



TAPA (Color blanco o plata)
Cover (white or silver) / Couvercle (blanc ou argenté)

	Ref.	€*	
○	31221	5,00	1
●	31222	12,00	1

*PVP según tarifa STH Fontanería & Calefacción en vigor. Condiciones de descuentos comerciales Fontanería y calefacción.
 *PVP according to STH Plumbing & Heating current gross price list. Conditions of commercial discounts Plumbing and heating.
 *PVP selon tarif STH Plomberie et Chauffage en vigueur. Conditions de remises commerciales Plomberie et Chauffage.

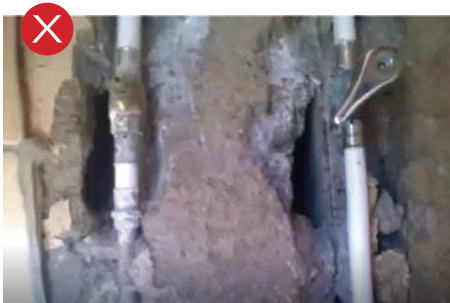

Rociadores

Shower heads
Pommes de douche

ANGEL
630X245 mm

Rociador empotrado

Concealed shower head
Pomme de douche encastrée



Efecto cascada
Cascade effect
Effet en cascade

Efecto lluvia
Rain effect
Effet de pluie

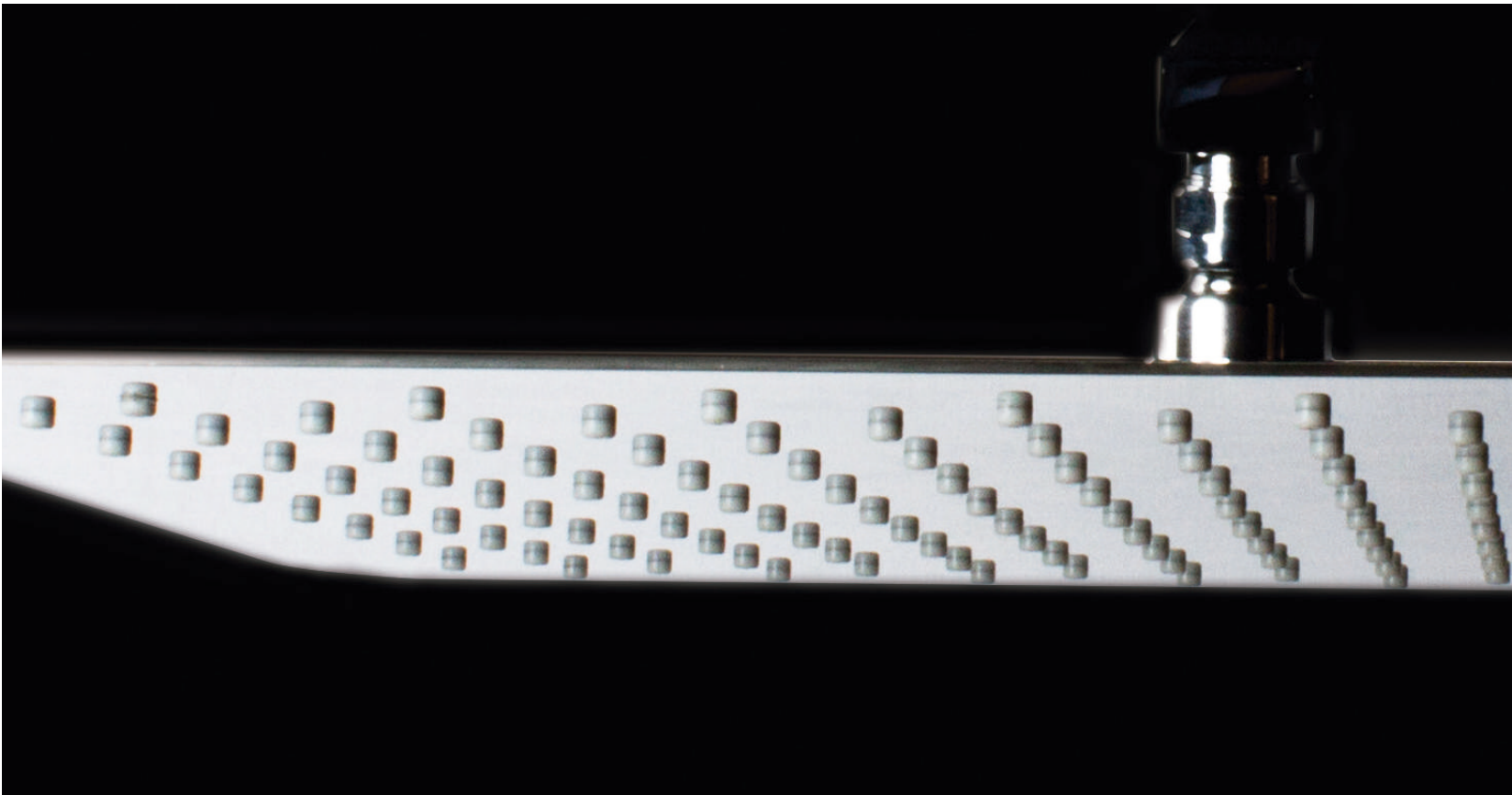

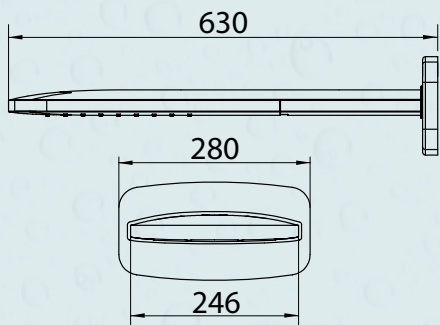

Gomas de silicona
Silicone rubber
Caoutchouc de silicone

Acabado blanco
White finish
Fini blanc

Acabado cromado
Chrome finish
Fini chrome



Ref.	€	
60308	507,00	-

Rociador empotrado con caída lluvia y cascada. 2 vías
Concealed shower head with rain and waterfall effect. 2 outlet diverter
Pomme de douche encastré avec effet pluie et cascade. 2 voies

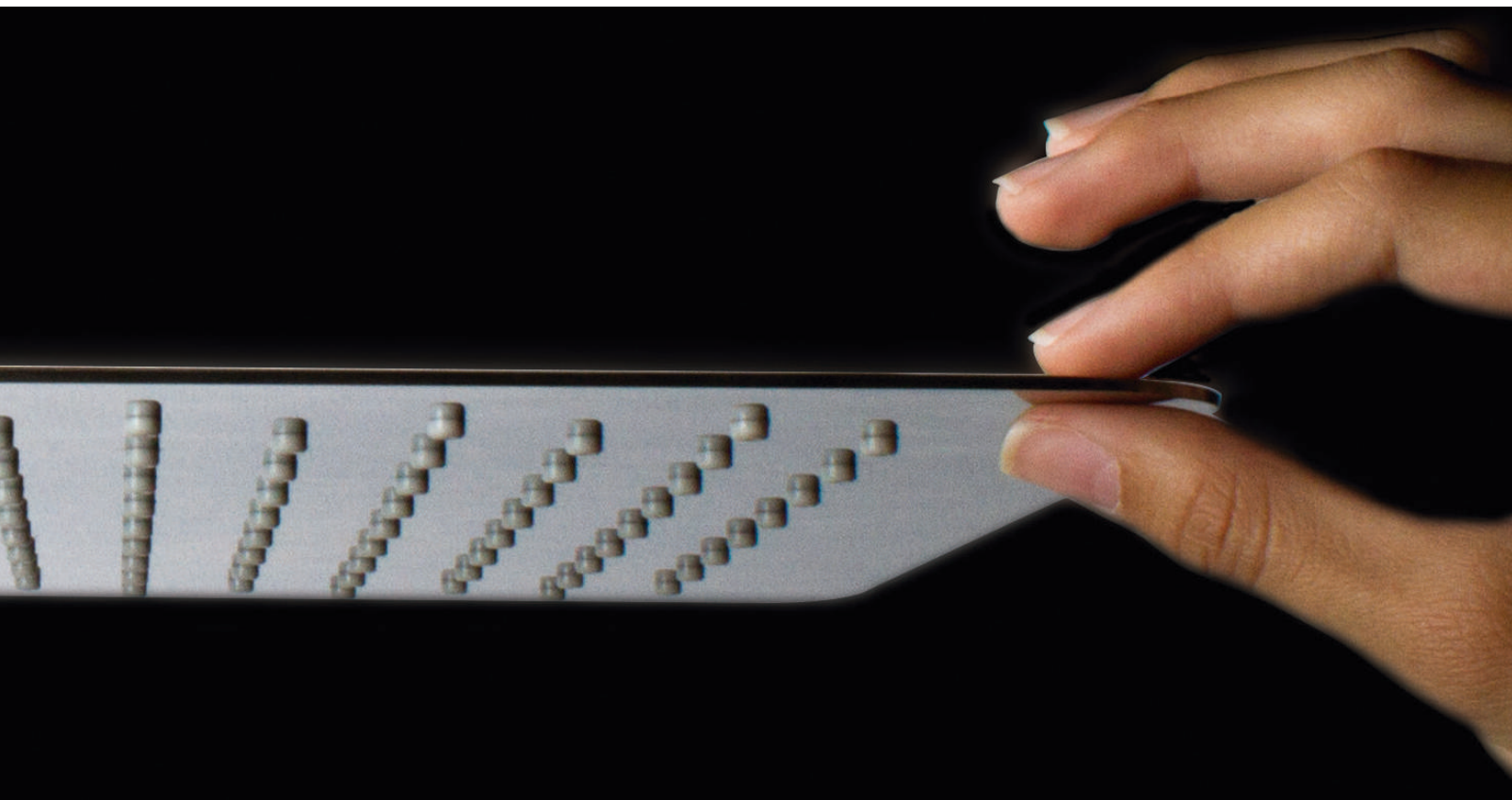

Rociadores

Shower heads
Pommes de douche

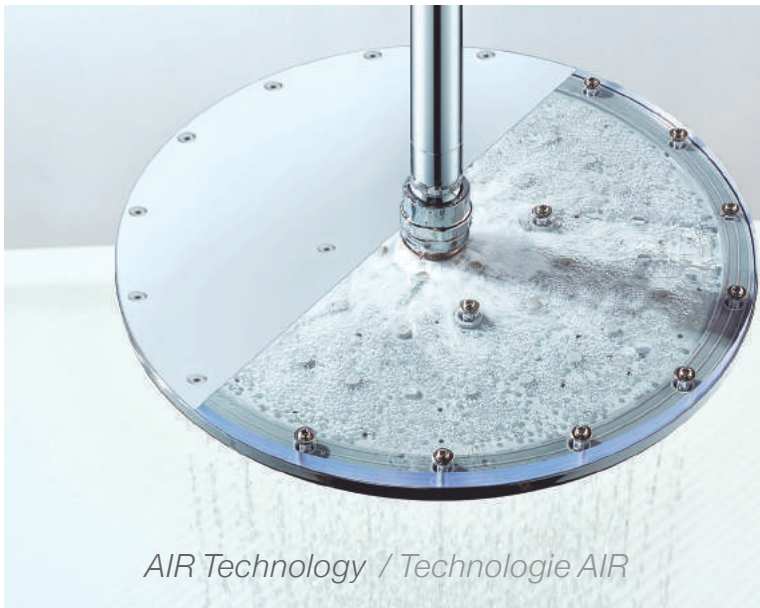

Tech AIR

Los rociadores Clever usan la tecnología AIR Advanced. Inyectando aire antes de la salida del agua, se consigue dar volumen a las gotas obteniendo una sensación más suave y confortable en la ducha. También se reduce el consumo de agua hasta un **30%**.

Clever shower heads use the advanced technology AIR Advanced. Mixing air with the incoming water reduces the water consumption at least 30%.

Les pommes de douche Clever sont équipées de la technologie AIR Advanced la plus avancée. L'injection d'air avant la sortie d'eau permet de donner du volume aux gouttes, et d'obtenir une sensation plus douce et confortable sous la douche. Elle permet aussi d'économiser jusqu'à 30% de consommation d'eau et d'énergie.



-30%
Water reduce

AIR Technology / Technologie AIR

1 Función SLIM INOX AIR

Rociador a rótula, de acero inoxidable, anticálculo.
Stainless steel Shower head, swivel, smart lime cleaning.
Pomme de douche inox, anti calcaire.

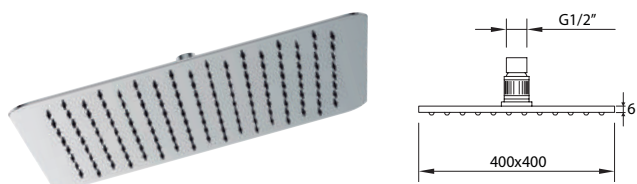

	Ref.	€	📦
400x400 mm INOX AIR	99688	225,00	5
300x300 mm INOX AIR	99693	120,00	8
250x250 mm INOX AIR	99692	90,00	8
200x200 mm INOX AIR	99600	65,00	12

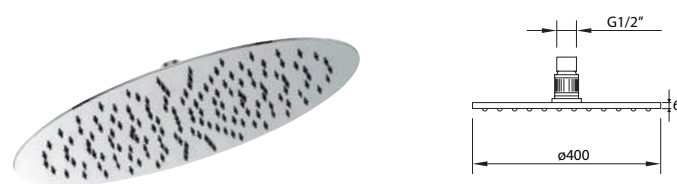

	Ref.	€	📦
Ø400 mm INOX AIR	99689	225,00	5
Ø300 mm INOX AIR	99691	120,00	8
Ø250 mm INOX AIR	99690	90,00	8
Ø200 mm INOX AIR	99603	65,00	12

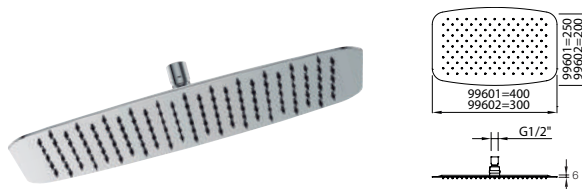

	Ref.	€	📦
400x250 mm INOX AIR	99601	225,00	5
300x200 mm INOX AIR	99602	139,00	8

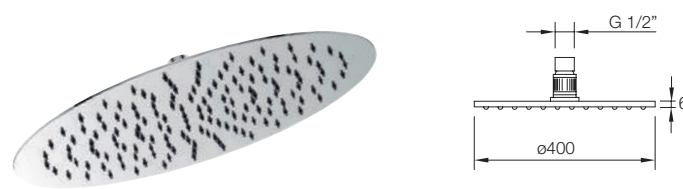

	Ref.	€	📦
Ø400 mm INOX	97276	225,00*	-
SLIM Ø300 mm INOX	98899	99,00*	-

* Hasta agotar existencias
While stocks last / Jusqu'à épuisement des stocks

1 **Función**
Function-Function

LATÓN Brass - Laiton

Rociador de latón a rótula, anticalcáreo.
Brass Shower head, swivel, smart lime cleaning.
Pomme de douche laiton anti calcaire.



INFINITY
200X200 mm

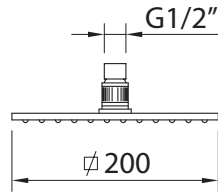

Ref.	€	Box
ACS BRASS 99685	166,00	12

BIMINI
145x200 mm

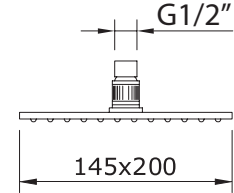

Ref.	€	Box
BRASS 99686	157,00	12

MINAMI
Ø200 mm

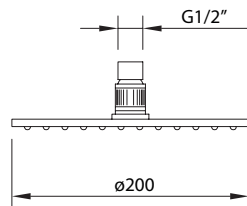

Ref.	€	Box
ACS BRASS 99687	142,00	12

TAMPA
Ø150 mm

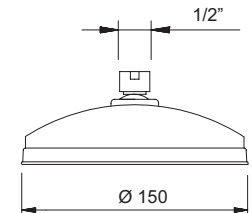

Ref.	€	Box
BRASS 96437	87,00	8

1 **Función**
Function-Function

ABS AIR

Rociador de ABS a rótula, anticalcáreo.
ABS Shower head, swivel, smart lime cleaning.
Pomme de douche ABS anti calcaire.



HEXAGON AIR
Ø230 mm

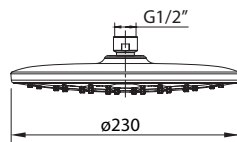

Ref.	€	Box
ABS AIR 60306	37,00	-

SYVARI EVO AIR
Ø225 mm

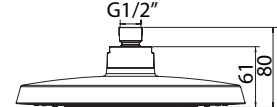

Ref.	€	Box
ABS AIR 60301	37,00	8

STYLE AIR
240X190 mm

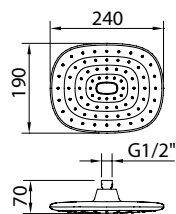

Ref.	€	Box
ABS AIR 99606	39,00	32

ROUND AIR
Ø120 mm

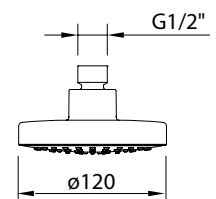

Ref.	€	Box
ABS AIR 99604	25,00	60



BEAM Ø230 mm

Con salida de agua a alta presión vaporizada.

High pressure outlet with spray water sensation.

Avec sortie d'eau à haute pression vaporisée.

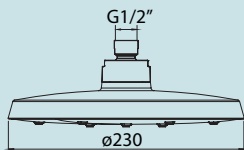

Ref. €

ABS	BEAM	60303	58,00	-
------------	-------------	-------	-------	---



SLIM CIRCULAR Ø300 mm

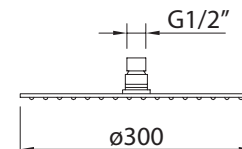

Ref.	€	
ABS	98892	139,00 1

TREND 260x190 mm

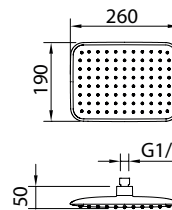

Ref.	€	
ABS	99608	44,00 24

CITY Ø225 mm

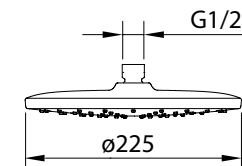

Ref.	€	
ABS	99607	35,00 20

KUBE 200X200 mm

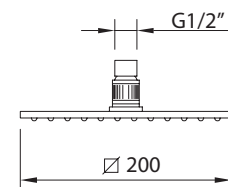

Ref.	€	
ABS	98672	44,00 1

CIRCULAR Ø200 mm

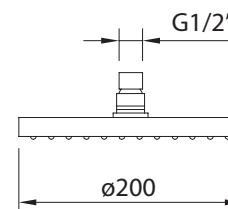

Ref.	€	
ABS	98518	44,00 16

3 Funciones

ABS

Rociador de ABS, anticalcáreo.
ABS Shower head, smart lime cleaning.
Pomme de douche ABS anti calcaire.



ZANZIBAR Ø80 mm

Con brazo de ducha
With shower arm | Avec bras de douche

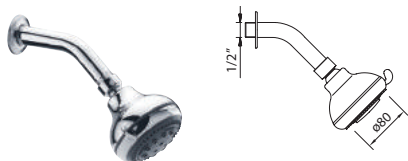

Ref.	€	📦
ABS 96141	26,00	50

ZANZIBAR Ø80 mm

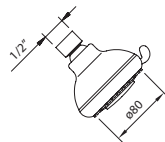

Ref.	€	📦
ABS 96114	17,00	50

KYOVA Ø80 mm

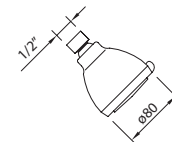

Ref.	€	📦
ABS 97996	16,00	5

AUTOCLEAN Ø230 mm

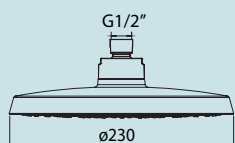

Ref.	€	📦
ABS 60305	62,00	1

Rociador AutoClean (Autolimpiable)

Autoclean shower head
Pomme de douche autoclean

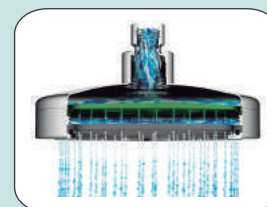

El rociador Auto limpiable evita que se taponen los orificios de salida de agua a través de un sistema interno por agujas.

The shower rain self-cleaning avoids the water outlets to be blocked due to an internal system with needles.

La pomme de douche autonettoyante évite l'entartrage des jets d'eau, grâce à un dispositif intégré qui combine gravité et pression d'eau pour nettoyer les orifices.

El sistema consigue mantener la trayectoria original de la salida del agua ofreciendo una sensación natural de lluvia.

The system maintains the original water trajectory offering a natural rain sensation.

Ce dispositif permet au jet d'eau de conserver sa trajectoire originale vous offrant une sensation de pluie naturelle en permanence.

Brazos rociador Shower arms Bras de douche

BIMINI 400 mm

Brazo para cabezal de ducha, latón. Pared.
Shower arm, brass. Wall.
Bras pour tête de douche, laiton. Mur.

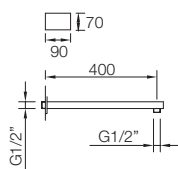

Ref.	€	📦
98000	66,00	15

LUZIA 330 mm

Brazo para cabezal de ducha, latón. Pared.
Shower arm, brass. Wall.
Bras pour tête de douche, laiton. Mur.

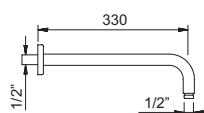

Ref.	€	📦
96153	41,00	50

ROOF 200 mm

Brazo para cabezal de ducha, latón. Techo.
Shower arm, brass. Roof.
Bras pour tête de douche, laiton. Toit.

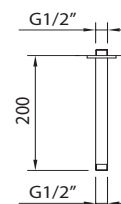

Ref.	€	📦
98005	21,00	20

Conjuntos ducha Shower kits Ensembles barre de douche

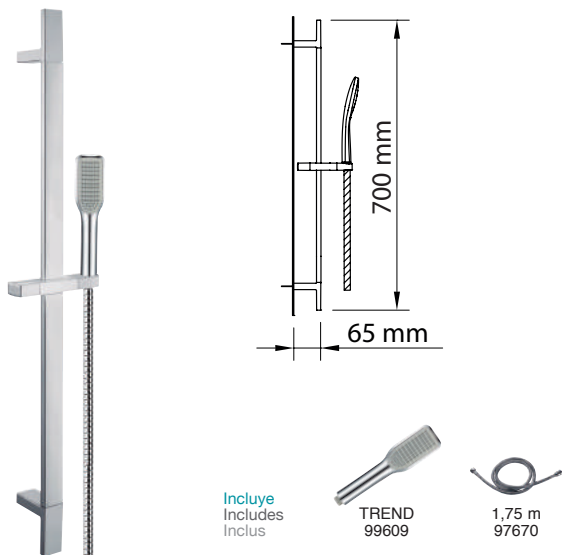

Incluye
Includes
Inclus

TREND
99609

1,75 m
97670

TREND - 30x10x700 mm
CONJUNTO BARRA DUCHA
Sliding bar set | Ensemble barre de douche.
ABS

Ref.	€	📦
99626	88,00	10

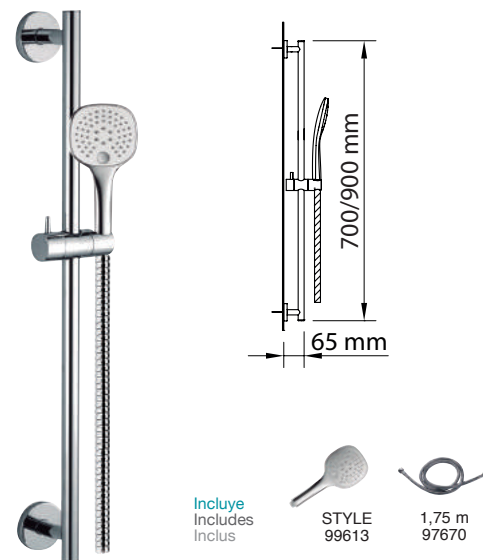

Incluye
Includes
Inclus

STYLE
99613

1,75 m
97670

STYLE
CONJUNTO BARRA DUCHA
Sliding bar set | Ensemble barre de douche.
ABS

	Ref.	€	📦
ø19x700 mm	99627	83,00	15
ø19x900 mm	99628	89,00	15



Incluye
Includes
Inclus

CITY AIR
99615

1,75 m
97670

CITY AIR
CONJUNTO BARRA DUCHA
Sliding bar set | Ensemble barre de douche.
ABS

	Ref.	€	📦
ø19x700 mm	99624	64,00	15
ø19x900 mm	99625	69,00	15

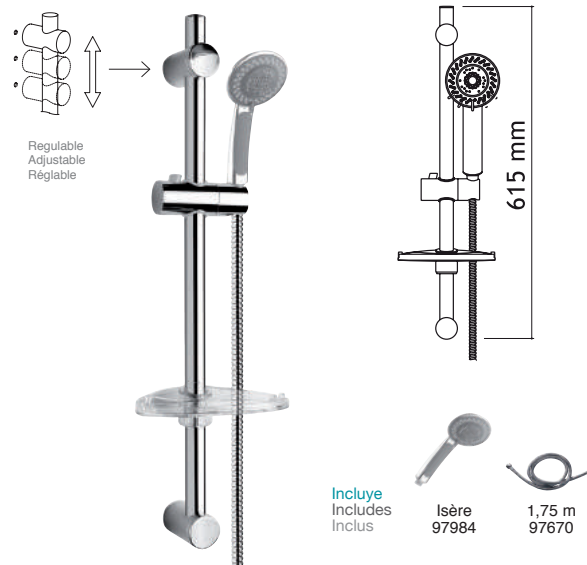

Incluye
Includes
Inclus

Isère
97984

1,75 m
97670

MICHIGAN - Ø25x615 mm
CONJUNTO DUCHA
Sliding bar set | Ensemble barre de douche

Barra de ducha ABS con jabonera extraíble.
ABS Shower kit and adjustable rail with rub clean handset and removable soap dish.
Porte savon amovible. ABS.

	Ref.	€	📦
ACS	97988	89,00	2



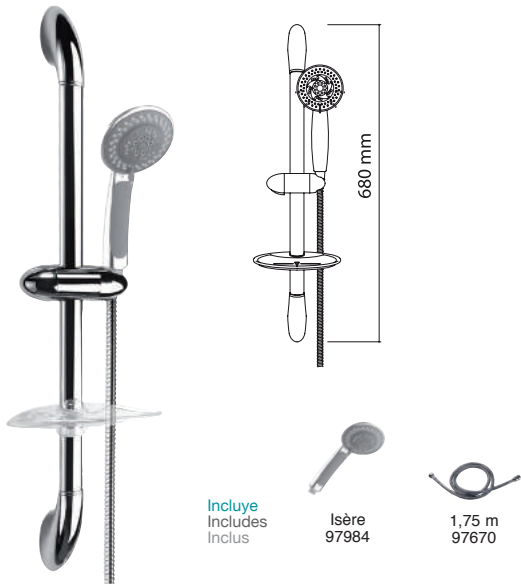

LEMAN - 680 mm
CONJUNTO DUCHA
Sliding bar set | Ensemble barre de douche

Barra de ducha ABS con jabonera extraíble.
 ABS Shower kit and adjustable riser rail with rub clean handset and removable soap dish.
 Porte savon amovible. ABS.

Ref.	€	
97986	83,00	2



BAIKAL - Ø25x600 mm
CONJUNTO DUCHA
Sliding bar set | Ensemble barre de douche

Barra de ducha ABS con jabonera extraíble.
 ABS Shower kit and adjustable riser rail with rub clean handset and removable soap dish.
 Porte savon amovible. ABS.

Ref.	€	
97985	71,00	2

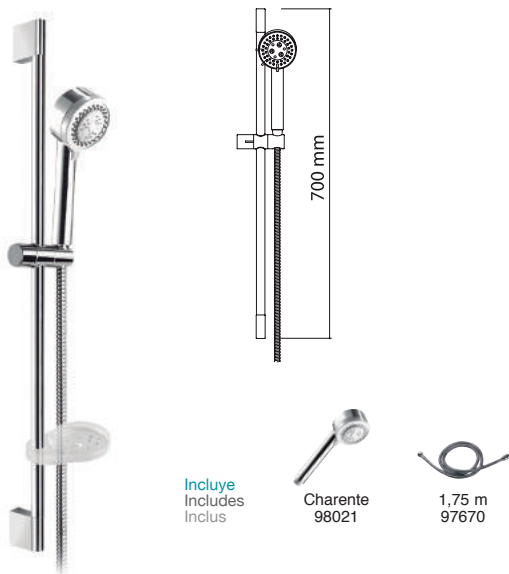

VICTORIA - Ø20x700 mm
CONJUNTO DUCHA
Sliding bar set | Ensemble barre de douche

Barra de ducha ABS con jabonera extraíble.
 ABS Shower kit and adjustable rail with rub clean handset and removable soap dish.
 Porte savon amovible. ABS.

Ref.	€	
97987	71,00	2



NO EXTENSIBLE NOT EXTENDABLE. NON EXTENSIBILE

KIT BOX
CONJUNTO BARRA DUCHA
Shower bar set | Colonne de douche

Ref.	€	
99623	224,00	1

Barras de ducha

Sliding bars
Barres de douche

NEW

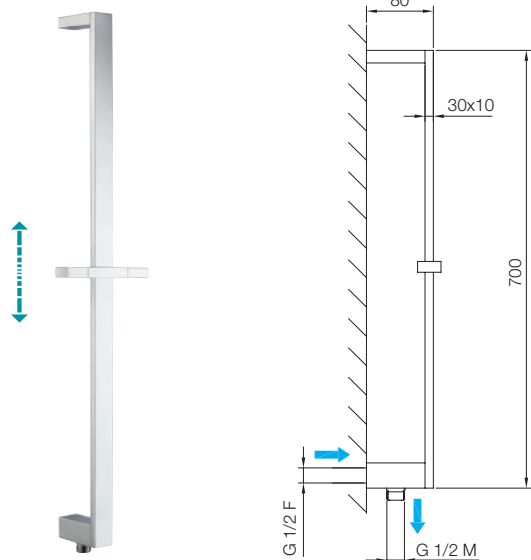

TREND - 30x10x700 mm
BARRA DE DUCHA EMPOTRADA
Concealed sliding bar
Barre de douche encastré



Ref.	€	
BRASS 60690	148,00	-

NEW

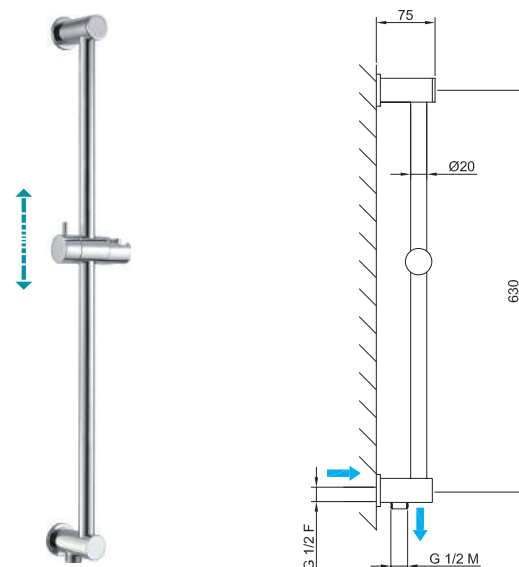

CITY - Ø20x715 mm
BARRA DE DUCHA EMPOTRADA
Concealed sliding bar
Barre de douche encastré



Ref.	€	
BRASS 60691	121,00	-

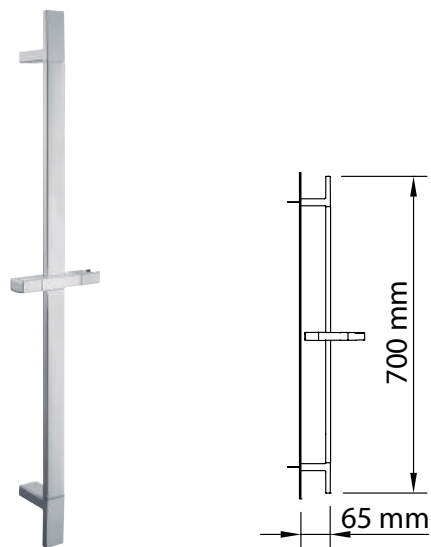

TREND 30x10x700 mm
BARRA DE DUCHA
Sliding bar
Barre de douche

Ref.	€	
99620	68,00	10

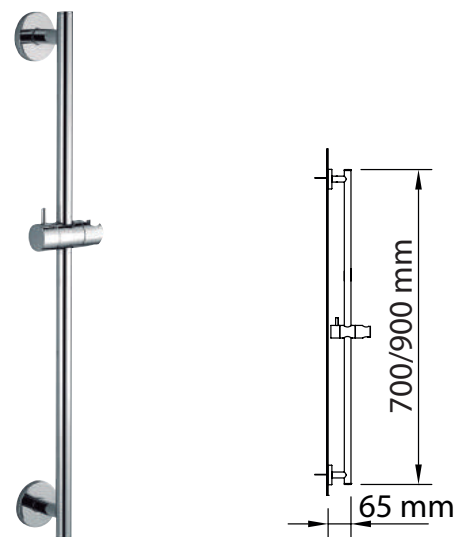

STYLE
BARRA DE DUCHA
Sliding bar
Barre de douche

	Ref.	€	
Ø19x700 mm	99621	42,00	15
Ø19x900 mm	99622	55,00	15



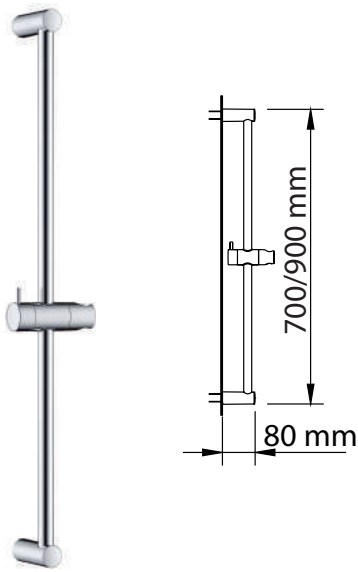

CITY
BARRA DE DUCHA
Sliding bar / Barre de douche

	Ref.	€	📦
ø19x700 mm	99618	41,00	15
ø19x900 mm	99619	43,00	15

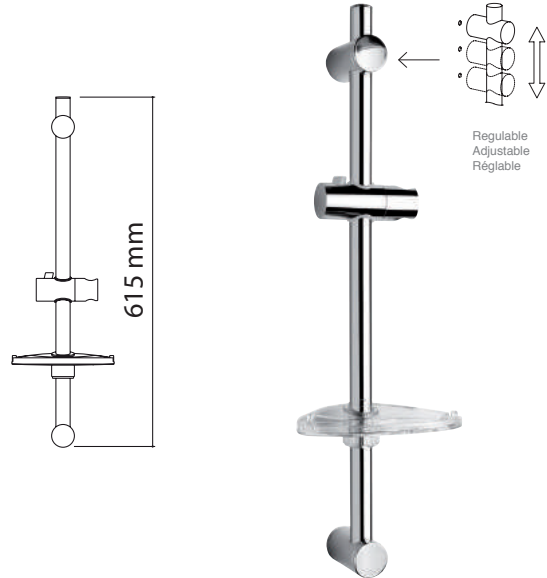

EIRE ø25x615 mm
BARRA DE DUCHA
Sliding bar / Barre de douche

Con jabonera extraíble.
Removable soap dish.
Porte savon amovible.

	Ref.	€	📦
	97992	59,00	2

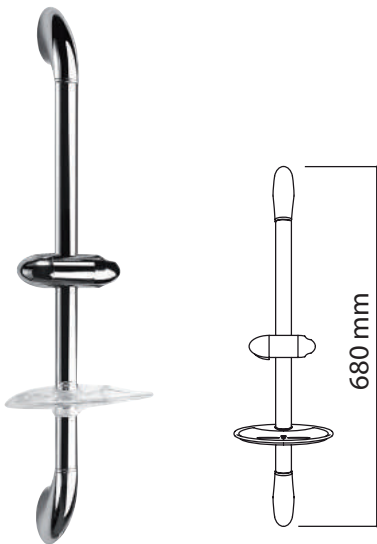

GARDA 680 mm
BARRA DE DUCHA
Sliding bar / Barre de douche

Con jabonera extraíble.
Removable soap dish.
Porte savon amovible.

	Ref.	€	📦
	97990	55,00	2

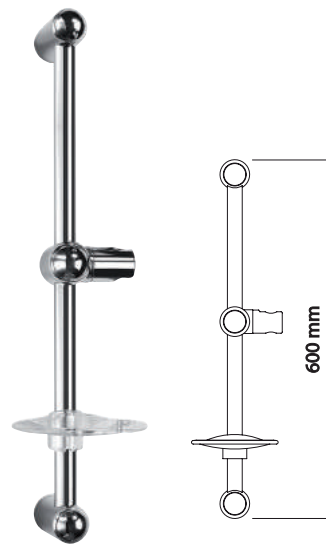

ARAL ø25x600 mm
BARRA DE DUCHA
Sliding bar / Barre de douche

Con jabonera extraíble.
Removable soap dish.
Porte savon amovible.

	Ref.	€	📦
	97989	48,00	2

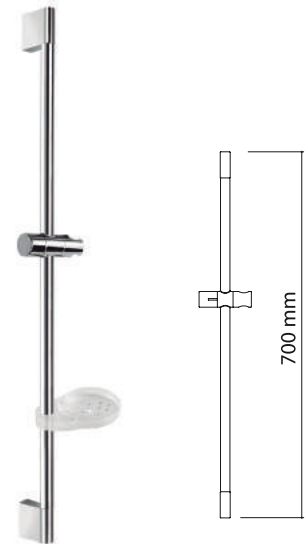

MALAWI ø20x700 mm
BARRA DE DUCHA
Sliding bar / Barre de douche

Con jabonera extraíble.
Removable soap dish.
Porte savon amovible.

	Ref.	€	📦
	97991	46,00	2

Caños empotrar

Bath spouts
Becs baignoire

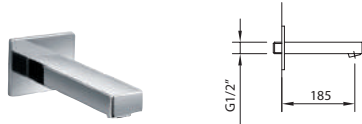

BIMINI 185 mm
CAÑO MURAL
Bath spout | Bec

Caño mural para baño. Latón
Bath wall spout. Brass
Bec murale pour bains. Laiton.



Ref.	€	📦
97999	64,00	20



MIKURA 170 mm
CAÑO MURAL
Bath spout | Bec

Caño mural para baño. Latón
Bath wall spout. Brass
Bec murale pour bains. Laiton.



Ref.	€	📦
97368	41,00	10



CAIMAN 185 mm
CAÑO MURAL
Bath spout | Bec

Caño mural para baño. Latón
Bath wall spout. Brass
Bec murale pour bains. Laiton.



Ref.	€	📦
98004	35,00	20

Jets hidromasaje

Body jets
Jets



SQUARE 135x135
JET HIDROMASAJE EMPOTRAR
Concealed body jets | Jets encastré

Cuadrado articulado. ABS
Articulated square. ABS
Carré articulé. ABS

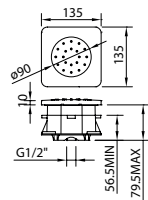

Ref.	€	📦
99616	86,00	18



ROUND Ø135
JET HIDROMASAJE EMPOTRAR
Concealed body jets | Jets encastré

Redondo articulado. ABS
Articulated round. ABS
Round articulé. ABS

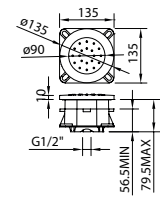

Ref.	€	📦
99617	86,00	18



SQUARE 48x48, 6 l/m - 3 bar
JET HIDROMASAJE
Body jets | Jets

Cuadrado, 2 piezas. Latón
Square, 2 pieces. Brass
Carré, 2 pièces. Laiton

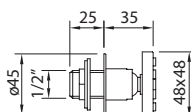

Ref.	€	📦
98440	104,00	10



ROUND Ø60, 6 l/m - 3 bar
JET HIDROMASAJE
Body jets | Jets

Redondo, 2 piezas. Latón
Round, 2 pieces. Brass
Round, 2 pièces. Laiton

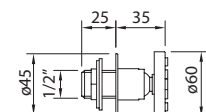

Ref.	€	📦
98441	104,00	10



Teléfono duchas

Handsets
Douchette

Tech AIR



AIR Technology / Technologie AIR

Los teléfonos de ducha Clever,

usan la tecnología AIR Advanced. Inyectando aire antes de la salida del agua, se consigue dar volumen a las gotas obteniendo una sensación más suave y confortable en la ducha. También se reduce el consumo de agua hasta un **30%**.

Clever handsets use the advanced technology AIR Advanced. Mixing air with the incoming water reduces the water consumption at least 30%.

Les douchettes Clever sont équipées de la technologie AIR Advanced la plus avancée. L'injection d'air avant la sortie d'eau permet de donner du volume aux gouttes, et d'obtenir une sensation plus douce et confortable sous la douche. Elle permet aussi d'économiser jusqu'à 30% de consommation d'eau et d'énergie.



-30%
Water reduce



5 Funciones

ABS

Ducha 5 posiciones, ABS cromado.
Multi-function rub clean handset. Chromed ABS
Douchette 5 positions, ABS chromé.



HEXAGON AIR | 5F | Ø100 mm
DUCHA | Handset | Douchette

Ref.	€	📦
60307	18,00	-



TANGANYKA | 5F | Ø100 mm
DUCHA | Handset | Douchette

Ref.	€	📦
ACS 97994	27,00	-



ISÈRE | 5F | Ø100 mm
DUCHA | Handset | Douchette

Ref.	€	📦
ACS 97984	25,00	-



Teléfono duchas

Handsets
Douchette

5
Funciones
Fonctions

Tanganika

Cod. 97994 (Ver pág./See page/Voir la page 231)



Espuma
Foam / Mousseur



Lluvia
Rain / Pluie



Masaje
Massage / Massage



Niebla
Fog / Brume



Spray
Spray / Spray

3
Funciones
Fonctions

Beam

Cod. 60304 (Ver pág./See page/Voir la page 233)



Lluvia
Rain / Pluie



Masaje
Massage / Massage



Spray
Spray / Spray



BEAM
Con salida de agua a alta presión vaporizada.
High pressure outlet with spray water sensation.
Avec sortie d'eau à haute pression vaporisée.

BEAM | 3F | Ø120 mm
DUCHA | Handset | Douchette

Ref.	€	
BEAM 60304	29,00	-



STYLE | 3F | 100x120 mm
DUCHA | Handset | Douchette

Ref.	€	
99610	31,00	48



STYLE | 3F | 120x120 mm
DUCHA | Handset | Douchette

Ref.	€	
99613	27,00	60



SYVARI EVO AIR | 3F | Ø100 mm
DUCHA | Handset | Douchette

Ref.	€	
60302	18,00	-



CITY AIR | 3F | Ø100 mm
DUCHA | Handset | Douchette

Ref.	€	
99615	17,00	60



SYVARI | 3F | Ø100 mm
DUCHA | Handset | Douchette

Ref.	€	
ACS 98884	18,00	1



SYSMA | 3F | Ø90 mm
DUCHA | Handset | Douchette

Ref.	€	
98888	26,00	1

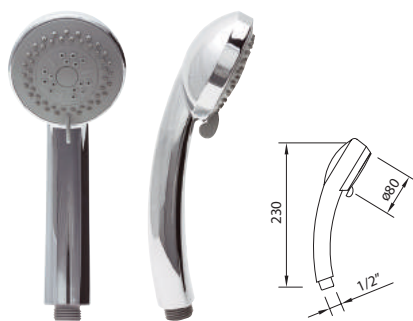
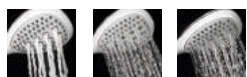

VIENNE | 3F | Ø80 mm
DUCHA | Handset | Douchette

Ref.	€	
ACS 97983	21,00	8



Teléfono duchas

Handsets
Douchette

1
Función
Function-Fonction

ABS

Ducha 1 posición, ABS cromado.
Single-function rub clean handset. Chromed ABS
Douchette 1 position, ABS chromé.



STYLE AIR | 1F | 100x120 mm
DUCHA | Handset | Douchette

Ref.	€	📦
99611	18,00	60

9 l/m, 3 bar



STYLE AIR | 1F | 120x120 mm
DUCHA | Handset | Douchette

Ref.	€	📦
99612	24,00	60

9 l/m, 3 bar



TREND | 1F | 55x100 mm
DUCHA | Handset | Douchette

Ref.	€	📦
99609	16,00	100

9 l/m, 3 bar



CITY AIR | 1F | Ø100 mm
DUCHA | Handset | Douchette

Ref.	€	📦
99614	16,00	60

9 l/m, 3 bar



NF | 1F | Ø80 mm
DUCHA | Handset | Douchette

Ref.	€	📦
99129	14,00	1

ACS NF



NANKAI | 1F | Ø90 mm
DUCHA | Handset | Douchette

Ref.	€	📦
97142	16,00	50

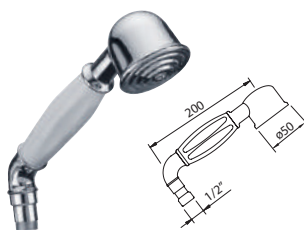

ANTIGONA | 1F | Ø50 mm
DUCHA | Handset | Douchette

Ref.	€	📦
90758	19,00	50

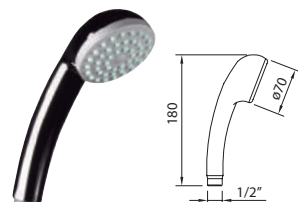

S12 | 1F | Ø70 mm
DUCHA | Handset | Douchette

Ref.	€	📦
98342	7,90	1

ACS

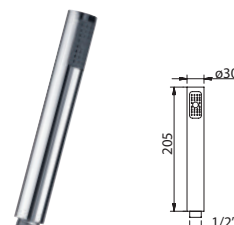

CAIMAN | 1F
DUCHA | Handset | Douchette

Ref.	€	📦
90796	13,00	50

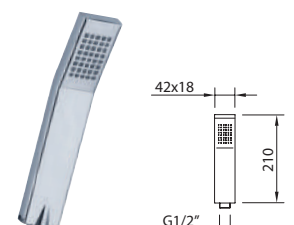

MARINA | 1F
DUCHA | Handset | Douchette

Ref.	€	📦
96786	22,00	50

Latón / Brass / Laiton

Soportes Wall brackets Supports de douchette

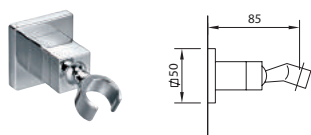

PASCUA
SOPORTE ARTICULADO
Articulated holder
Support douchette orientable

Latón cromado.
Chromed brass.
Laiton chromé.

Ref.	€	📦
97112	28,00	20



TONGA
SOPORTE ARTICULADO
Articulated holder
Support douchette orientable

Latón cromado.
Chromed brass.
Laiton chromé.

Ref.	€	📦
97113	19,00	20



LUZON
SOPORTE ARTICULADO
Articulated holder
Support douchette orientable

ABS cromado.
Chromed ABS.
ABS chromé.

Ref.	€	📦
96458	12,00	20



MOA
SOPORTE ARTICULADO
Articulated holder
Support douchette orientable

ABS cromado.
Chromed ABS.
ABS chromé.

Ref.	€	📦
96942	8,50	50



SAONA
SOPORTE ARTICULADO
Articulated holder
Support douchette orientable

ABS cromado.
Chromed ABS.
ABS chromé.

Ref.	€	📦
96413	8,00	20

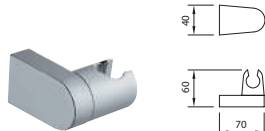

HABANA XTREME
SOPORTE ARTICULADO
Articulated holder
Support douchette orientable

ABS cromado.
Chromed ABS.
ABS chromé.

Ref.	€	📦
98208	5,50	20

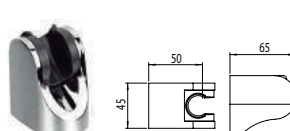

START
SOPORTE ARTICULADO
Articulated holder
Support douchette orientable

ABS cromado.
Chromed ABS.
ABS chromé.

Ref.	€	📦
60311	5,50	-

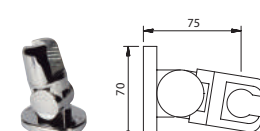

HABANA
SOPORTE ARTICULADO
Articulated holder
Support douchette orientable

ABS cromado.
Chromed ABS.
ABS chromé.

Ref.	€	📦
90011	4,35	20

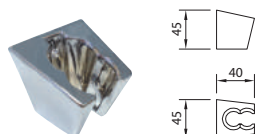

S12
SOPORTE FIJO
Fix holder
Support douchette fixe

ABS cromado, 2 posiciones.
Chromed ABS, 2 positions.
ABS chromé, 2 positions.

Ref.	€	📦
98343	3,31	24

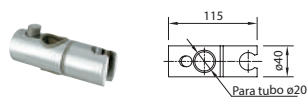

BASIC BOX
SOPORTE DESLIZANTE ARTICULADO
Articulated holder
Support coulissant articulé

Para tubo ø20.
Tube ø20.
Pour tube ø20.

Ref.	€	📦
98997	15,00	20

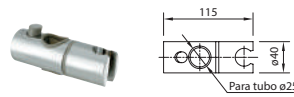

CEILAN
SOPORTE DESLIZANTE ARTICULADO
Articulated holder
Support coulissant articulé

Para tubo ø25.
Tube ø25.
Pour tube ø25.

Ref.	€	📦
96264	21,00	20

Flexibles

Flexibles
Flexibles

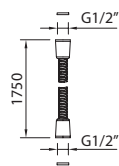

SILVER HOSE 1,75m

FLEXIBLE | Flexible | Flexible

PVC. Acabado en plata.

PVC. Silver finish.

PVC. Finition argent



Ref.	€	📦
98880	23,00	1
98022	36,00	1

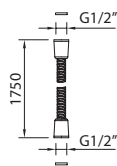

FLEXIBLE

Flexible | Flexible
1,75m

Tubo flexible con record 1/2" para ducha teléfono con 2 records cónicos.

Latón.

Flexible 1/2" for handshower with 2 conical nuts. Brass.

Ecrous coniques. Laiton.

Ref.	€	📦
96122	15,00	100

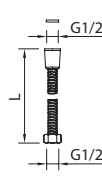

FLEXIBLE

Flexible | Flexible

97816: L=1,20 m Inox, stainless steel, inox

90703: L=1,50 m Inox, stainless steel, inox

90704: L=1,75 m Inox, stainless steel, inox

97670: L=1,75 m Inox, stainless steel, inox

97114 cromado: L=1,80 m Inox, stainless steel, inox

99128: L=1,75 m Inox, stainless steel, inox

Ref.	€	📦	Ref.	€	📦
97816	6,50	15	97670	9,50	50
90703	7,00	50	97114	16,00	50
90704	9,00	40	99128	10,00	50

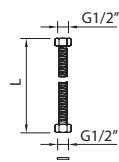

FLEXIBLE

Flexible | Flexible

Tubo flexible con 2 records hexagonales para 99136.

Flexible with 2 hexagonal nuts for 99136.

Ecrous hexagonaux pour 99136.

97396: L=35 cm Inox, stainless steel, inox

97397: L=60 cm Inox, stainless steel, inox

Ref.	€	📦
97396	3,75	24
97397	6,00	50

98880
SILVER HOSE
Flexible
Flexible | Flexible



Salidas flexo

Wall outlets
Sorties flexible

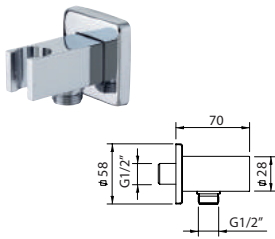

BIMINI

Salida flexo mural con soporte. Latón
Wall hose bib outlet with holder. Brass.
Sortie flexible murale, avec suport. Laiton.

Ref.	€	📦
98235	27,00	20

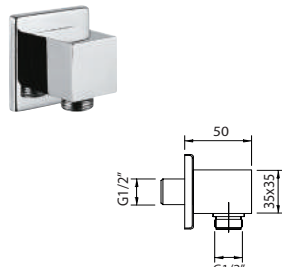

BIMINI

Salida flexo mural. Latón
Wall hose bib outlet. Brass.
Sortie flexible murale. Laiton.

Ref.	€	📦
98001	26,00	20

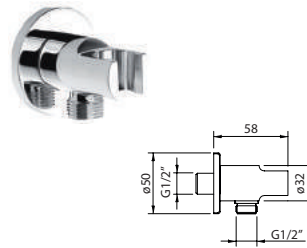

CAIMAN urban

Salida flexo mural con soporte. Latón
Wall hose bib outlet with holder. Brass.
Sortie flexible murale, avec suport. Laiton.

Ref.	€	📦
98236	27,00	10

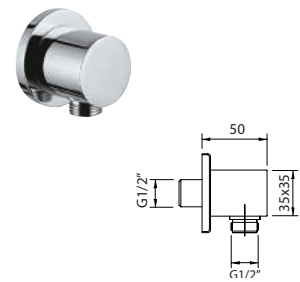

CAIMAN urban

Salida flexo. Latón
Hose bib outlet. Brass.
Sortie flexible. Laiton.

Ref.	€	📦
97148	26,00	10



98235 BIMINI

Salido flexo mural con soporte
Wall hose bib outlet with holder
Sortie flexible murale, avec suport





GAMA BOX

Clever Box, visual y atractivo

Atractive and visual / Pratique et attrayant



Clever Box Termostático
Thermostatic Clever Box
Clever Box Thermostatique
240



Clever Box Monomando
Single lever Clever Box
Clever Box mitigeur
242



iclever box
244



Expositores de sobremesa
Floorstand
Présentoir de comptoir
246

clever box

TERMOSTÁTICO. Visual y atractivo.
 Thermostatic. Atractive and visual
 Thermostatique. Pratique et attrayant

*Este producto se suministra en formato Clever Box (Pack indivisible de 4 unidades)

This product is provided in Clever Box packaging (Indivisible packaging of 4 units)

Ce produit est conditionné en Clever Box (Pack indivisible de 4 unités)

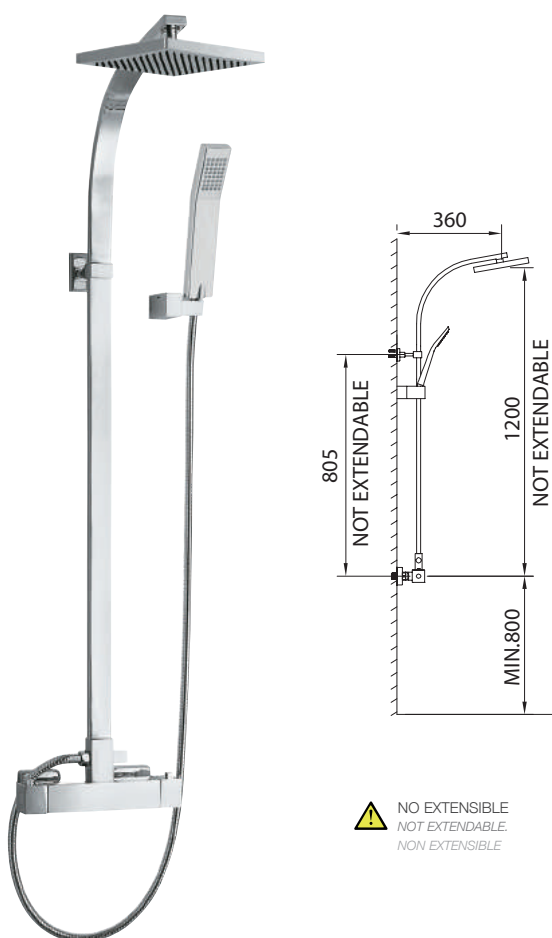

! NO EXTENSIBLE
 NOT EXTENDABLE.
 NON EXTENSIBLE

KUADRAT THERM BOX

CONJUNTO DE DUCHA TERMOSTÁTICO

Thermostatic shower system

Colonne thermostatique douche

Mezclador termostático de ducha con inversor automático. Thermostatic shower valve with automatic diverter.

Support douchette orientable, inverseur automatique, pomme de douche, douchette et flexible

Incluye
 Includes
 Inclus



Kube
 98672



Marina
 96786



1,75 m
 97670



Saona
 96413

Ref.	€	📦
98671	595,00	4*

Clever Box
 64,5 x 40 x 122 cm



98027



96253

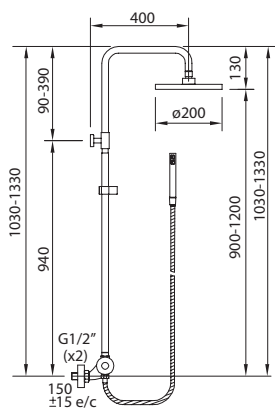

Inversor incorporado en la maneta de caudal
Diverter built in the flow handle
Inverseur intégré dans la poignée

EXTENSIBLE CIRCULAR THERM BOX

CONJUNTO DE DUCHA TERMOSTÁTICO EXTENSIBLE
Adjustable thermostatic shower system | Colonne
thermostatique douche extensible

Mezclador termostático de ducha con tubo extensible Circular (98517), soporte articulado deslizante.
Adjustable thermostatic shower valve with diverter built in.
Support douchette coulissant, inverseur céramique, pomme de douche, douchette et flexible

Incluye
Includes
Inclus



Ref.	€	Q	
60412	420,00	4*	Clever Box 36 x 35 x 92 cm

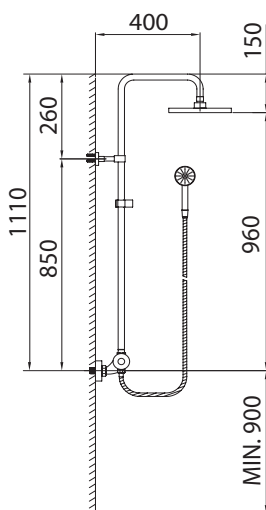

⚠ NO EXTENSIBLE
NOT EXTENDABLE
NON EXTENSIBLE

Inversor incorporado en la maneta de caudal
Diverter built in the flow handle
Inverseur intégré dans la poignée

CIRCULAR THERM BOX

CONJUNTO DE DUCHA TERMOSTÁTICO
Thermostatic shower system
Colonne thermostatique douche

Mezclador termostático de ducha soporte articulado deslizante.
Thermostatic shower valve with diverter built in.
Support douchette coulissant, inverseur céramique, pomme de douche, douchette et flexible

Incluye
Includes
Inclus



Ref.	€	Q	
60413	389,00	4*	Clever Box 36 x 35 x 92 cm



clever box

MONOMANDO. Visual y atractivo.
Single lever. Attractive and visual
Mitigeur. Pratique et attrayant

*Este producto se suministra en formato Clever Box
(Pack indivisible de 4 unidades)

*This product is provided in Clever Box packaging
(Indivisible packaging of 4 units)*

*Ce produit est conditionné en Clever Box (Pack indivisible
de 4 unités)*

Clever Box 97 x 58 x 49,5 cm

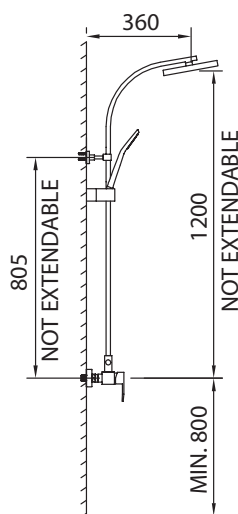

NO EXTENSIBLE
NOT EXTENDABLE.
NON EXTENSIBLE

KUADRAT MANUAL BOX

CONJUNTO DE DUCHA Shower system Colonne mitigeur douche

Mezclador de ducha con tubo e inversor automático.
Adjustable shower valve with automatic diverter.
Support douchette orientable, inverseur automatique,
pomme de douche, douchette et flexible

Incluye
Includes
Inclus



Kube
98672



Marina
96786



1,75 m
97670



Saona
96413

	Ref.	€	
	98850	499,00	4*

Clever Box
64,5 x 40 x 122 cm



99003



97371



96253

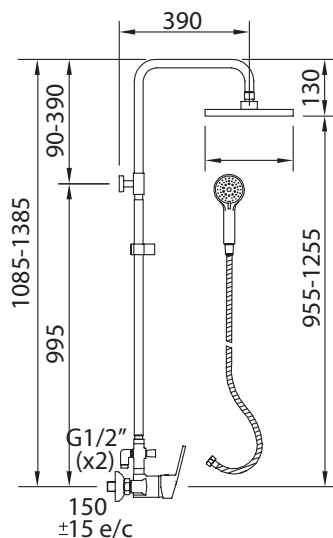

EXTENSIBLE CIRCULAR MANUAL BOX

CONJUNTO DE DUCHA EXTENSIBLE
Adjustable shower system
Colonne mitigeur douche extensible

Mezclador de ducha con tubo extensible Circular (98517), soporte articulado deslizable.
Adjustable shower valve with automatic diverter.
Support douchette coulissant, inverseur automatique, pomme de douche, douchette et flexible

Incluye
Includes
Inclus



	Ref.	€	
ec1	98527	320,00	4* Clever Box 36 x 35 x 92 cm

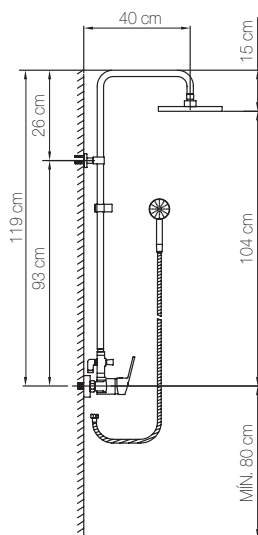
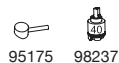

CIRCULAR MANUAL BOX

CONJUNTO DE DUCHA
Shower system
Colonne mitigeur douche

Mezclador de ducha soporte articulado deslizable.
Adjustable shower valve with automatic diverter.
Ensemble de douche, pomme de douche supérieure articulée, douchette et flexible.

Incluye
Includes
Inclus



	Ref.	€	
ec1	99142	289,00	4* Clever Box 36 x 35 x 92 cm

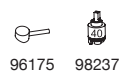

! NO EXTENSIBLE
NOT EXTENDABLE
NON EXTENSIBLE

iclever box

MONOMANDO. Visual y atractivo.
Single lever. Attractive and visual
Mitigeur. Pratique et attrayant

NEW



Clever Box 59 x 32 x 12 cm

START xtreme

Conjunto monomando ducha empotrada 2 vias Box
Concealed shower single lever mixer 2 ways
Mitigeur de douche encastré 2 voies complet box

Ref.	€	Box
ec2 60694	295,00	4*

* (Pack indivisible de 4 unidades)
* (Indivisible Packaging of 4 units)
* (Pack indivisible de 4 unités)

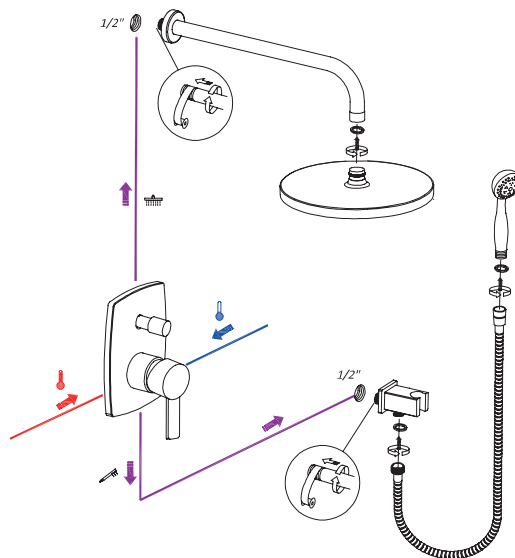

Incluye
Includes
Inclus

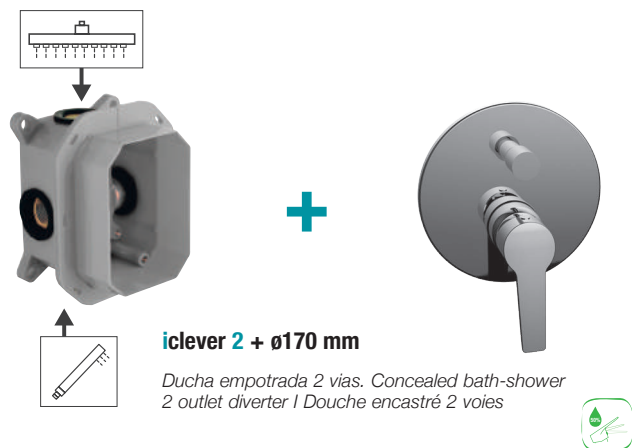

Slim INOX AIR ø250 mm 99690
1 Función | 1 Function | 1 Fonction



Luzia 330 mm 96153



1,75 m 97670



Bimini 98236



City AIR ø100 mm ABS 99615
3 Funciones | 3 Functions | 3 Fonctions



Instrucciones instalación
Instructions installation
Instructions d'installation

clever

G R I F E R Í A



Sobremesa

Perfectos para el mostrador

Floorstand, perfect for your shop

Présentoir de comptoir, parfait pour votre point de vente



Télefono de ducha SYVARI 3F Ø100mm 98884

Handset SYVARI
Douchette SYVARI

Expositor sobremesa SYVARI

Floorstand SYVARI
Présentoir de comptoir SYVARI

Ref.	€	📦
98885	17,50	16*

* (Pack indivisible de 16 unidades)
*(Indivisible Packaging of 16 units)
*(Pack indivisible de 16 unités)



Flexible SilverHose 1,75m 98880

SilverHose Flexible
Flexible SilverHose

Expositor sobremesa SilverHose

Floorstand SilverHose
Présentoir de comptoir SilverHose

Ref.	€	📦
98881	22,00	10*

* (Pack indivisible de 10 unidades)
*(Indivisible Packaging of 10 units)
*(Pack indivisible de 10 unités)



Expositor sobremesa 4 ACCESSORIES BATH BOX

Floorstand 4 Accessories Bath Box

Présentoir de comptoir 4 Accessoires Bath Box

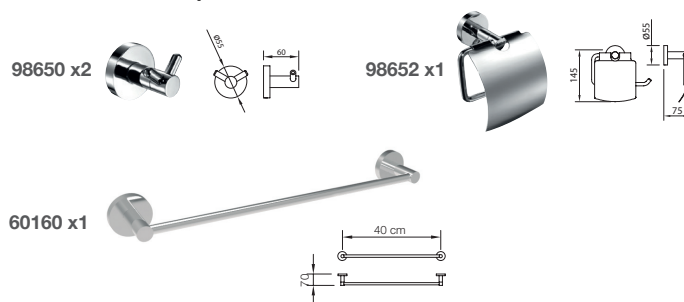

Ref.	€	📦
99450	95,00	8*

* (Pack indivisible de 8 unidades)
*(Indivisible Packaging of 8 units)
*(Pack indivisible de 8 unités)

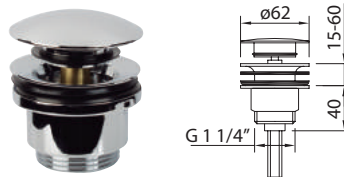

LEO BOX
Pop-up quick-clac metal 1-1/4"
Vidage quick-clac metal 1-1/4"

Ref.	€	📦
60418	14,00	24*

* (Pack indivisible de 24 unidades)
 *(Indivisible Packaging of 24 units)
 *(Pack indivisible de 24 unités)

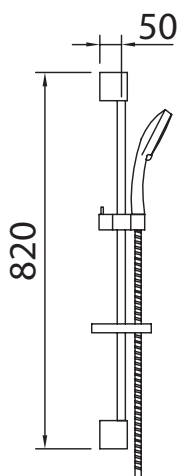

Conjunto de ducha SYVARI 3F
Shower Set SYVARI
Ensemble barre de douche SYVARI

Ref.	€	📦
98886	64,00	12*

Clever Box
 62 x 22 x 79 cm

* (Pack indivisible de 12 unidades)
 *(Indivisible Packaging of 12 units)
 *(Pack indivisible de 12 unités)

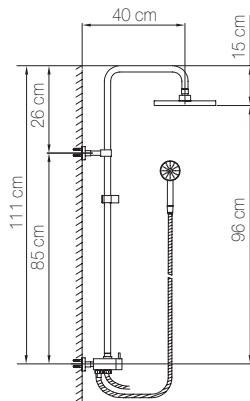

CIRCULAR KIT SHOWER BOX

CONJUNTO BARRA DUCHA | Shower bar set
Colonne de douche

Incluye
 Includes
 Inclus



Ref.	€	📦
99136	223,00	4*

Clever Box
 36 x 35 x 92 cm



NO EXTENSIBLE
NOT EXTENDABLE
NON EXTENSIBLE

* (Pack indivisible de 4 unidades)
 *(Indivisible Packaging of 4 units)
 *(Pack indivisible de 4 unités)



Accesorios de baño

Bath accessories / Accessoires de salle de bain



PLATINUM
250



elegance
252



xtreme
254



urban
256

Ventu **Accesorios de baño** Bathroom accessories | Accessoires de salle de bain

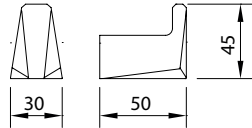

PERCHA VENTU Clothes hook | Patère

Latón cromado. Kit fijación incluido.
Brass chromed. Fixing set included.
Laiton chromé. Kit de fixation inclus.

Ref.	€	📦
99470	19,00	30

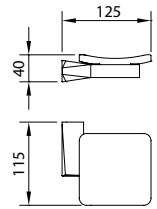
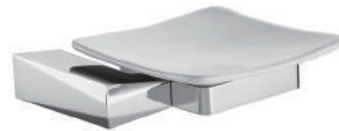

JABONERA VENTU Soap Dish | Porte-savon

Jabonera de pared de cristal glaseada. Kit fijación incluido.
Wall mounted frosted glass soap dish. Fixing set included.
Porte-savon mural en verre. Kit de fixation inclus.

Ref.	€	📦
99471	48,00	10

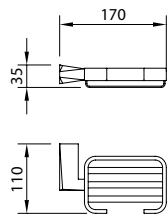

JABONERA VENTU Soap Dish | Porte-savon

Jabonera de pared. Kit fijación incluido.
Wall mounted soap dish. Fixing set included.
Porte-savon mural. Kit de fixation inclus.

Ref.	€	📦
99472	64,00	10

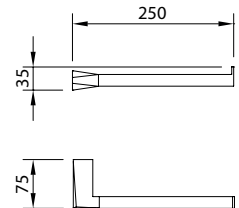

PORTAVASOS VENTU Brush holder | Porte-verre

Latón cromado. Kit fijación incluido.
Brass chromed. Fixing set included.
Laiton chromé. Kit de fixation inclus.

Ref.	€	📦
99473	46,00	10

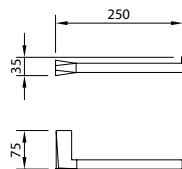

TOALLERO VENTU Towel rail | Porte-serviette

Latón cromado. Kit fijación incluido.
Brass chromed. Fixing set included.
Laiton chromé. Kit de fixation inclus.

Ref.	€	📦
99474	42,00	10

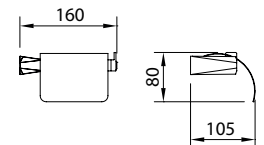

PORTARROLLO VENTU Toilet roll | Porte-rouleau

Latón cromado. Kit fijación incluido.
Brass chromed. Fixing set included.
Laiton chromé. Kit de fixation inclus.

Ref.	€	📦
99475	54,00	10



PORTARROLLO SIN TAPA VENTU
Tissue holder without cover | Porte-rouleau sans couvercle

Latón cromado. Kit fijación incluido.
Brass chromed. Fixing set included.
Laiton chromé. Kit de fixation inclus.

Ref.	€	📦
99476	39,00	10



TOALLERO VENTU
Towel rail | Porte-serviette

Latón cromado. Kit fijación incluido.
Brass chromed. Fixing set included.
Laiton chromé. Kit de fixation inclus.

	Ref.	€	📦
40cm	60156	76,00	12
63cm	99477	81,00	10



TOALLERO DOBLE VENTU
Double towel rail | Porte-serviette double-barre

Latón cromado. Kit fijación incluido.
Brass chromed. Fixing set included.
Laiton chromé. Kit de fixation inclus.

Ref.	€	📦
99478	101,00	10



PORTATOALLAS VENTU
Towel rack | Porte-serviettes

Latón cromado. Kit fijación incluido.
Brass chromed. Fixing set included.
Laiton chromé. Kit de fixation inclus.

Ref.	€	📦
99479	166,00	4

ESCOBILLERO PARED VENTU
Toilet brush holder | Porte balai wc mural

Cristal gaseado. Latón cromado. Kit fijación incluido.
Frosted glass. Brass chromed. Fixing set included.
Cristal glacé. Laiton chromé. Kit de fixation inclus.



Ref.	€	📦
60563	97,00	-

Productos relacionados
Related products
Produits connexes



VENTU 99428
Lavabo 85
Basin mixer 85
Mittigeur lavabo 85

PAG. 22



VENTU 99439
Baño ducha fijación suelo
Floor standing bath-shower mixer
Mittigeur bain-douche sur colonne avec prise d'eau au sol

PAG. 23

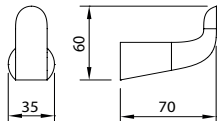

PERCHA
Clothes hook | Patère

Latón cromado. Kit fijación incluido.
Brass chromed. Fixing set included.
Laiton chromé. Kit de fixation inclus.

Ref.	€	📦
99451	20,00	30

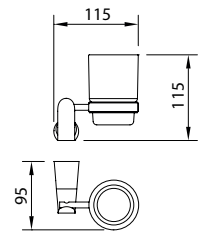

PORTAVASOS
Brush holder | Porte-verre

Latón cromado. Kit fijación incluido.
Brass chromed. Fixing set included.
Laiton chromé. Kit de fixation inclus.

Ref.	€	📦
99453	34,00	10

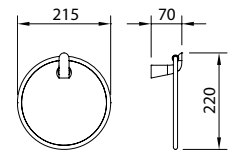

TOALLERO DE ANILLA
Towel ring | Porte-serviette anneau

Latón cromado. Kit fijación incluido.
Brass chromed. Fixing set included.
Laiton chromé. Kit de fixation inclus.

Ref.	€	📦
99454	37,00	10

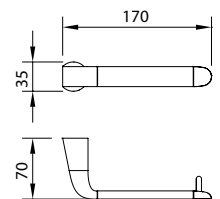

PORTARROLLO SIN TAPA
Tissue holder without cover | Porte-rouleau sans couvercle

Latón cromado. Kit fijación incluido.
Brass chromed. Fixing set included.
Laiton chromé. Kit de fixation inclus.

Ref.	€	📦
99455	34,00	10

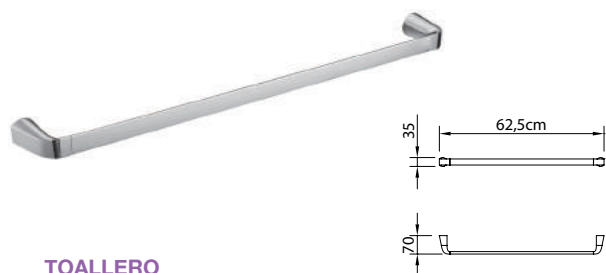

TOALLERO
Towel rail | Porte-serviette

Latón cromado. Kit fijación incluido.
Brass chromed. Fixing set included.
Laiton chromé. Kit de fixation inclus.

	Ref.	€	📦
40 cm	60157	50,00	12
62,5 cm	99456	65,00	10



TOALLERO DOBLE
Double towel rail | Porte-serviette double-barre

Latón cromado. Kit fijación incluido.
Brass chromed. Fixing set included.
Laiton chromé. Kit de fixation inclus.

	Ref.	€	📦
	99457	93,00	10

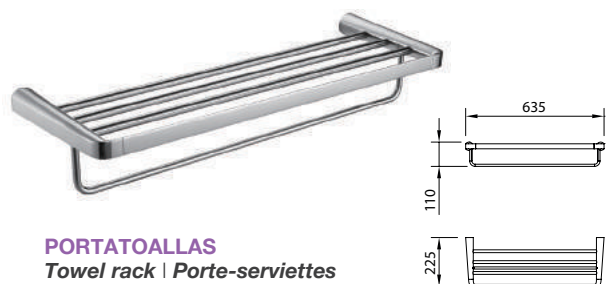

PORTATOALLAS
Towel rack | Porte-serviettes

Latón cromado. Kit fijación incluido.
Brass chromed. Fixing set included.
Laiton chromé. Kit de fixation inclus.

	Ref.	€	📦
	99458	166,00	4



ESCOBILLERO
Toilet brush holder | Porte balai wc mural

Cerámico. Latón cromado. Kit fijación incluido.
Ceramic. Brass chromed. Fixing set included
Céramique. Laiton chromé. Kit de fixation inclus.

	Ref.	€	📦
	60564	50,00	-

Productos relacionados
Related products
Produits connexes



PAG. 52

AGORA elegance _ 98680
Lavabo 95
Basin mixer 95
Mittigeur lavabo 95



PAG. 92

START elegance _ 60170
Lavabo 65
Basin mixer 65
Mittigeur lavabo 65



PAG. 297

VELA _ 97395_96255
Válvula desagüe metálico
Drain quick-clac metallic
Vidage métallique



PAG. 45

NINE elegance 60154
Ducha termostática
Thermostatic shower mixer
Mittigeur douche thermostatique

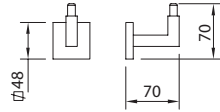

PERCHA Clothes hook | Patère

Latón cromado. Kit fijación incluido.
Brass chromed. Fixing set included.
Laiton chromé. Kit de fixation inclus.

Ref.	€	📦
98655	25,00	30

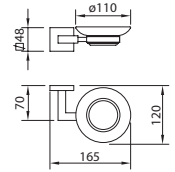

JABONERA Soap Dish | Porte-savon

Jabonera de pared de cristal gaseada. Kit fijación incluido.
Wall mounted frosted glass soap dish. Fixing set included.
Porte-savon mural de cristal glacé. Kit de fixation inclus.

Ref.	€	📦
98824	33,00	10

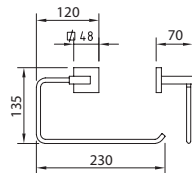
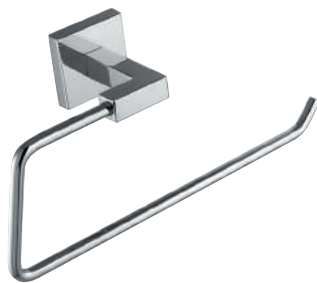

TOALLERO DE ANILLA Towel ring | Porte-serviette anneau

Latón cromado. Kit fijación incluido.
Brass chromed. Fixing set included.
Laiton chromé. Kit de fixation inclus.

Ref.	€	📦
98656	36,00	10

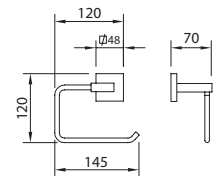

PORTARROLLO Toilet roll | Porte-rouleau

Latón cromado. Kit fijación incluido.
Brass chromed. Fixing set included.
Laiton chromé. Kit de fixation inclus.

Ref.	€	📦
98657	34,00	10

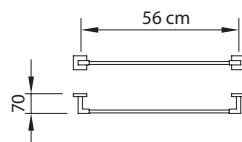

TOALLERO Towel rail | Porte-serviette

Latón cromado. Kit fijación incluido.
Brass chromed. Fixing set included.
Laiton chromé. Kit de fixation inclus.

	Ref.	€	📦
40 cm	60158	43,00	12
56 cm	98658	53,00	10

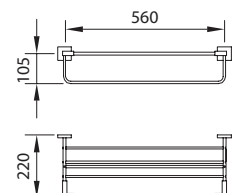

PORTATOALLAS Towel shelf | Porte-serviette

Latón cromado. Kit fijación incluido.
Brass chromed. Fixing set included.
Laiton chromé. Kit de fixation inclus.

Ref.	€	📦
98659	128,00	4



ESCOBILLERO
Toilet brush holder | Porte balai wc mural

Cristal glaseado. Latón cromado. Kit fijación incluido.
 Frosted glass. Brass chromed. Fixing set included.
 Cristal glacé. Laiton chromé. Kit de fixation inclus.

Ref.	€	
60565	43,00	-



Productos relacionados
 Related products
 Produits connexes



PAG. 34

MARINA EVO _ 99413
 Lavabo 110
 Basin mixer 110
 Mitigeur lavabo 110



PAG. 26

SAONA SLIM _ 60115
 Lavabo 115
 Basin mixer 115
 Mitigeur lavabo 115



PAG. 297

HYDRA _ 98675
 Válvula desagüe Universal
 Universal drain quick-clac
 Vidage Universel



PAG. 49

NINE Xtreme _ 60133
 Ducha termostática
 Thermostatic shower mixer
 Mitigeur douche thermostatique

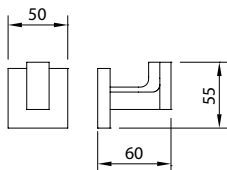

PERCHA
Clothes hook | Patère

Latón cromado. Kit fijación incluido.
Brass chromed. Fixing set included.
Laiton chromé. Kit de fixation inclus.

Ref.	€	📦
99459	23,00	30

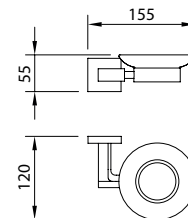

JABONERA
Soap Dish | Porte-savon

Jabonera de pared de cristal glaseada. Kit fijación incluido.
Wall mounted frosted glass soap dish. Fixing set included.
Porte-savon mural en verre. Kit de fixation inclus.

Ref.	€	📦
99460	34,00	10

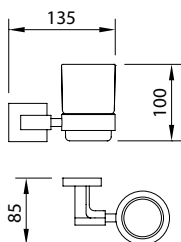

PORTAVASOS
Brush holder | Porte-verre

Latón cromado. Kit fijación incluido.
Brass chromed. Fixing set included.
Laiton chromé. Kit de fixation inclus.

Ref.	€	📦
99461	33,00	10

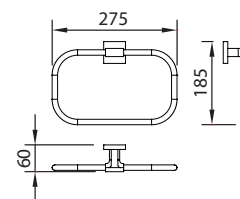

TOALLERO DE ANILLA
Towel ring | Porte-serviette anneau

Latón cromado. Kit fijación incluido.
Brass chromed. Fixing set included.
Laiton chromé. Kit de fixation inclus.

Ref.	€	📦
99462	47,00	10

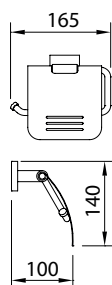

PORTARROLLO
Toilet roll | Porte-rouleau

Latón cromado. Kit fijación incluido.
Brass chromed. Fixing set included.
Laiton chromé. Kit de fixation inclus.

Ref.	€	📦
99463	43,00	10

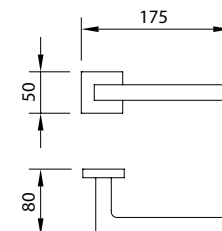

PORTARROLLO SIN TAPA
Tissue holder without cover | Porte-rouleau sans couvercle

Latón cromado. Kit fijación incluido.
Brass chromed. Fixing set included.
Laiton chromé. Kit de fixation inclus.

Ref.	€	📦
99464	32,00	10

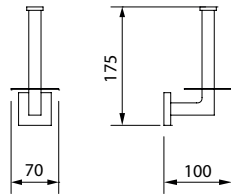

PORTARROLLO
Toilet roll | Porte-rouleau

Latón cromado. Kit fijación incluido.
Brass chromed. Fixing set included.
Laiton chromé. Kit de fixation inclus.

Ref.	€	
99465	35,00	10

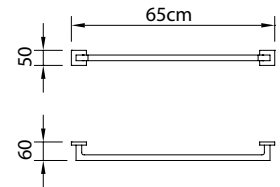

TOALLERO
Towel rail | Porte-serviette

Latón cromado. Kit fijación incluido.
Brass chromed. Fixing set included.
Laiton chromé. Kit de fixation inclus.

	Ref.	€	
40 cm	60159	50,00	12
65 cm	99466	55,00	10

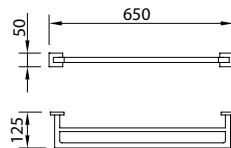

TOALLERO DOBLE
Double towel rail | Porte-serviette double-barre

Latón cromado. Kit fijación incluido.
Brass chromed. Fixing set included.
Laiton chromé. Kit de fixation inclus.

Ref.	€	
99467	86,00	10

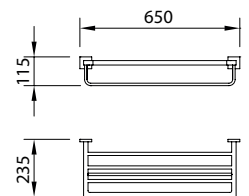

PORTATOALLAS
Towel shelf | Porte-serviette

Latón cromado. Kit fijación incluido.
Brass chromed. Fixing set included.
Laiton chromé. Kit de fixation inclus.

Ref.	€	
99468	128,00	4



ESCOBILLERO
Toilet brush holder | Porte balai wc mural

Cerámico. Latón cromado. Kit fijación incluido.
Ceramic. Brass chromed. Fixing set included.
Céramique. Laiton chromé. Kit de fixation inclus.

Ref.	€	
60566	68,00	-

Productos relacionados
Related products
Produits connexes



PAG. 62

ARTIC urban_98102
Lavabo 95
Basin mixer 95
Mitigeur lavabo 95



PAG. 141

NINE urban_60325
Ducha termostática
Thermostatic shower mixer
Mitigeur douche thermostatique



PAG. 297

LEO_98674
Válvula desagüe Universal
Universal drain quick-clac
Vidage Universel

urban 2 **Accesorios de baño**

Bathroom accessories | Accessoires de salle de bain

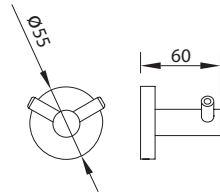

PERCHA *Clothes hook | Patère*

Latón cromado. Kit fijación incluido.
Brass chromed. Fixing set included.
Laiton chromé. Kit de fixation inclus.

Ref.	€	📦
98650	14,00	30

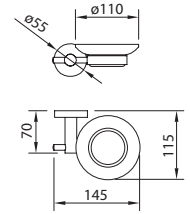

JABONERA *Soap Dish | Porte-savon*

Jabonera de pared de cristal gaseado. Kit fijación incluido.
Wall mounted frosted glass soap dish. Fixing set included.
Porte-savon mural en verre. Kit de fixation inclus.

Ref.	€	📦
98825	27,00	10

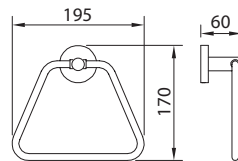

TOALLERO DE ANILLA *Towel ring | Porte-serviette anneau*

Latón cromado. Kit fijación incluido.
Brass chromed. Fixing set included.
Laiton chromé. Kit de fixation inclus.

Ref.	€	📦
98651	30,00	10

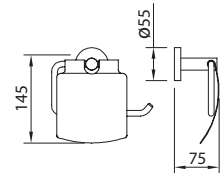

PORTARROLLO *Toilet roll | Porte-rouleau*

Latón cromado. Kit fijación incluido.
Brass chromed. Fixing set included.
Laiton chromé. Kit de fixation inclus.

Ref.	€	📦
98652	35,00	12

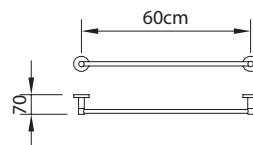

TOALLERO *Towel rail | Porte-serviette*

Latón cromado. Kit fijación incluido.
Brass chromed. Fixing set included.
Laiton chromé. Kit de fixation inclus.

	Ref.	€	📦
40cm	60160	35,00	12
60cm	98653	38,00	12

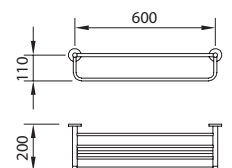

PORTATOALLAS *Towel shelf | Porte-serviette*

Latón cromado. Kit fijación incluido.
Brass chromed. Fixing set included.
Laiton chromé. Kit de fixation inclus.

Ref.	€	📦
98654	87,00	4

x3
Magnification

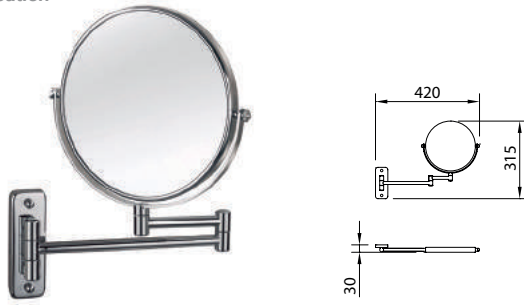

ESPEJO DE AUMENTO PARA LAVABO
Augmented mirror | Miroir grossissant

De doble cara, con visión normal y de 3 aumentos.
Latón cromado. Kit fijación incluido.
Double sided. One side with normal vision and one side with 3 x magnification. Brass chromed. Fixing set included.
Miroir double face avec vision normale et grossissement x 3.
Laiton chromé. Kit de fixation inclus.

Ref.	€	📦
99469	109,00	8

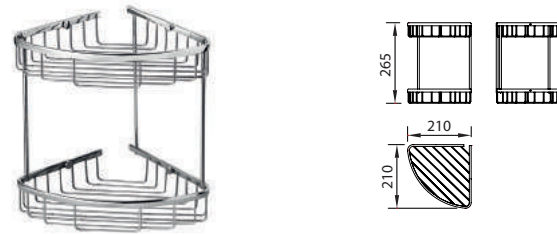

JABONERA DOBLE CROMO
Chromed soap double holder | Etagère d'angle chromée

Latón cromado. Kit fijación incluido.
Brass chromed. Fixing set included.
Laiton chromé. Kit de fixation inclus.

Ref.	€	📦
99480	102,00	8



JABONERA REJILLA CROMO
Chromed soap dish basket | Etagère droite chromée

Latón cromado. Kit fijación incluido.
Brass chromed. Fixing set included.
Laiton chromé. Kit de fixation inclus.

Ref.	€	📦
98826	48,00	10



JABONERA ESQUINA REJILLA CROMO
Chromed corner soap dish basket | Etagère d'angle chromée

Latón cromado. Kit fijación incluido.
Brass chromed. Fixing set included.
Laiton chromé. Kit de fixation inclus.

Ref.	€	📦
98827	43,00	10

Productos relacionados
Related products
Produits connexes



PAG. 74

WITH2 antigua _ 94474
Lavabo 65
Basin mixer 65
Mittigeur lavabo 65



PAG. 297

LEO _ 98674
Válvula desagüe Universal
Universal drain quick-clac
Vidage Universel



PAG. 140

NINE SLIM urban _ 60414
Ducha termostática
Thermostatic shower mixer
Mittigeur douche thermostatique



PAG. 246

Expositor sobremesa 4 ACCESORIOS BATH BOX _ 99450
Floorstand 4 Accessories Bath Box
Présentoir de comptoir 4 Accessoires Bath Box



PERCHA 4
Clothes hook | Barre 4 crochets

Acero inoxidable. Kit fijación incluido.
Stainless steel. Fixing set included.
Acier inoxydable. Kit de fixation inclus.

Ref.	€	📦	INOX
99481	23,00	30	INOX



PERCHA 5
Clothes hook | Barre 5 crochets

Acero inoxidable. Kit fijación incluido.
Stainless steel. Fixing set included.
Acier inoxydable. Kit de fixation inclus.

Ref.	€	📦	INOX
99482	28,00	30	INOX

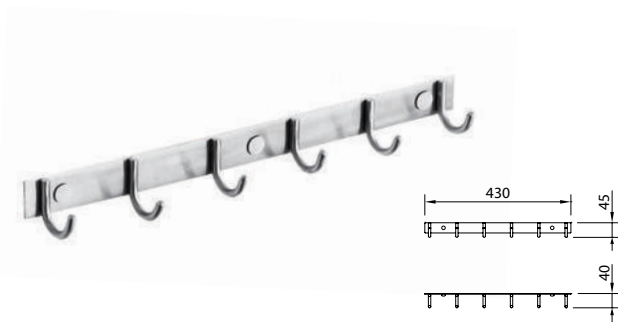

PERCHA 6
Clothes hook | Barre 6 crochets

Acero inoxidable. Kit fijación incluido.
Stainless steel. Fixing set included.
Acier inoxydable. Kit de fixation inclus.

Ref.	€	📦	INOX
99483	33,00	30	INOX

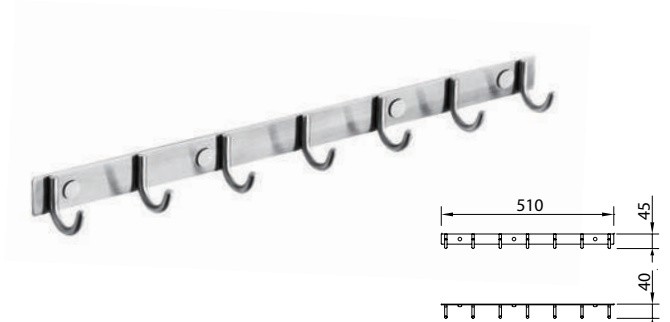

PERCHA 7
Clothes hook | Barre 7 crochets

Acero inoxidable. Kit fijación incluido.
Stainless steel. Fixing set included.
Acier inoxydable. Kit de fixation inclus.

Ref.	€	📦	INOX
99484	38,00	30	INOX

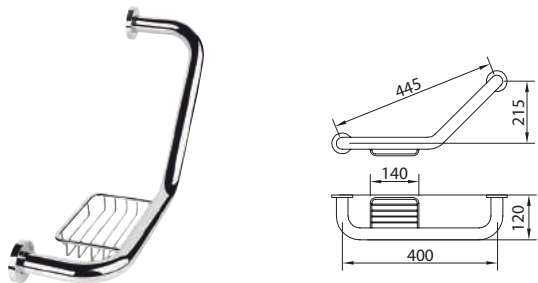

ASA DE SEGURIDAD CURVA CON JABONERA
Brass chrome security curve handle with soap dish
Barre de sécurité avec porte-savon
40cm

Latón cromado. Kit fijación incluido.
 Brass chromed. Fixing set included.
 Laiton chromé. Kit de fixation inclus.

Ref.	€	📦
98895	67,00	2

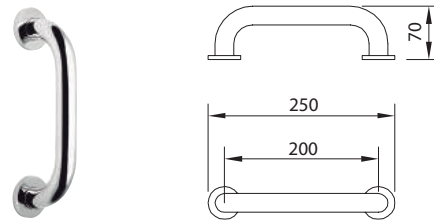

ASA DE SEGURIDAD
Brass chrome security curve handle | Barre de sécurité
20cm

Latón cromado. Kit fijación incluido.
 Brass chromed. Fixing set included.
 Laiton chromé. Kit de fixation inclus.

Ref.	€	📦
98896	45,00	6

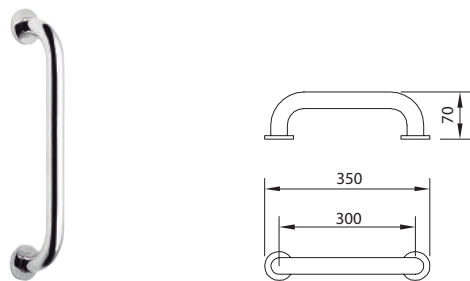

ASA DE SEGURIDAD
Brass chrome security curve handle |
Barre de sécurité

Latón cromado. Kit fijación incluido.
 Brass chromed. Fixing set included.
 Laiton chromé. Kit de fixation inclus.

Ref.	€	📦
98897	50,00	6



ESCOBILLERO
Toilet brush holder | Porte balai wc mural

Cristal glaseado. Latón cromado. Kit fijación incluido.
 Frosted glass. Brass chromed. Fixing set included.
 Cristal glacé. Laiton chromé. Kit de fixation inclus.

Ref.	€	📦
60567	37,00	-





COLECTIVIDADES

Clever para espacios colectivos

Clever for collective spaces
Clever pour les collectivités

NEW



Temporizados
Delay action
Temporisés
264

NEW



Electrónicos
Electronic
Électronique
266



Ducha higiénica
Shattaf
Douche hygiénique
270



Grifos individuales
Cold water taps
Robinets individuels
272



Maneta gerontológica
Medical lever
P.M.R.
274

Temporizados

Delay action
Temporisés

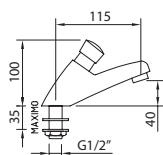

GRIFERIA TEMPORIZADA Delay action basin tap | Robinet temporisé

Grifo de repisa para lavabo, con aireador, 14 segundos, cartucho M26
Deck mounted basin tap, with aerator, 14 seconds, cartridge M26
Robinet simple, avec aérateur, 14 secondes cartouche M26

Ref.	€	📦
96127	55,00	24



cosedal 96164 90025 NEOPERL

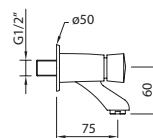

GRIFERIA TEMPORIZADA MURAL Wall mounted delay action basin tap | Robinet temporisé mural

Grifo mural para lavabo, con aireador, 14 segundos, cartucho M26
Wall mounted basin tap, with aerator, 14 seconds, cartridge M26
Robinet simple, avec aérateur, 14 secondes cartouche M26

Ref.	€	📦
96128	42,00	24



cosedal 96164 90025 NEOPERL

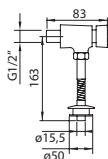

GRIFERIA TEMPORIZADA URINARIO MURAL Wall mounted urinal flush valve Robinet temporisé urinoir mural

Grifo mural de 1/2" para urinario, 7 segundos, cartucho M26.
Urinal 1/2", 7 seconds, cartridge M26.
Robinet temporisé urinoir 1/2", 7 secondes, cartouche M26.

Ref.	€	📦
92801	45,00	24



cosedal 96161

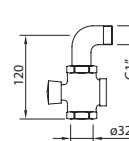

GRIFERIA TEMPORIZADA SANITARIO MURAL Wall mounted sanitary flush valve Robinet temporisé sanitaire mural

Fluxor exterior para urinario.
Urinal external fluxor.
Robinet temporisé urinoir mural.

Ref.	€	📦
96152	66,00	24



Nuevos temporizados con sistema auto-limpiable y mayor durabilidad

NEW

New delay action with self-cleaning system and greater durability

Nouveau robinet temporisé avec système d'auto-nettoyage et une plus grande durabilité



Cartucho auto-limpiable.

*Self-cleaning cartridge.
Cartouche autonettoyante.*



Aireador enrasado y antivandálico

*Aerated and anti-vandalism aerator.
Aérateur aéré et anti-vandalisme.*



Filtro antipartículas integrado en la entrada de agua.

*Particle filter integrated in the water inlet.
Filtre anti-particules intégré dans l'entrée d'eau.*

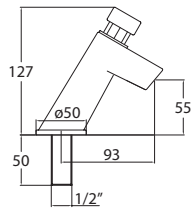

GRIFERIA TEMPORIZADA

Delay action basin tap | Robinet temporisé

Grifo de repisa para lavabo, con aireador, 14 segundos, cartucho M28
Deck mounted basin tap, with aerator, 14 seconds, cartridge M28
Robinet simple, avec aérateur, 14 secondes cartouche M28

Ref.	€	
60734	58,00	-



cosedal



60737



60149

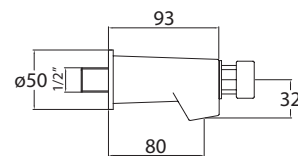

GRIFERIA TEMPORIZADA MURAL

Wall mounted delay action basin tap | Robinet temporisé mural

Grifo mural para lavabo, con aireador, 14 segundos, cartucho M28
Wall mounted basin tap, with aerator, 14 seconds, cartridge M28
Robinet simple, avec aérateur, 14 secondes cartouche M28

Ref.	€	
60735	45,00	-



cosedal



60737



60149

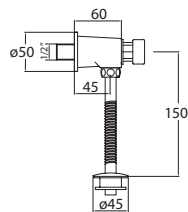

GRIFERIA TEMPORIZADA URINARIO MURAL

Wall mounted urinal flush valve Robinet temporisé urinoir mural

Grifo mural de 1/2" para urinario, 7 segundos, cartucho M28.
Urinal 1/2", 7 seconds, cartridge M28.
Robinet temporisé urinoir 1/2", 7 secondes, cartouche M28.

Ref.	€	
60736	48,00	-



cosedal



60738

Cartucho



Duración mecánica

Mechanic Duration / Durabilité mécanique

210.000

Ciclos de vida / Lifecycles / Cycles de vie

25 bars es la presión máxima que debe resistirse durante 60s.
Presión recomendable: **3 bars.**

*25 bars is the maximum pressure that must be resisted for 60s.
Recommended pressure: 3 bars.*

*25 bars est la pression maximale à laquelle il faut résister pendant
60 secondes. Pression recommandée: 3 bars.*

Según normativa EN-816

*Estos datos sólo son valores de referencia.
These data are only reference values. Ces données ne
sont que des valeurs de référence.

60734 / 60735 / 60736

Disponible a partir de Septiembre 2019

Available from September 2019 / Disponible à partir de Septembre 2019

Electrónicos

Electronic divises / Électronique

NEW

Nueva grifería electrónica

New electronic faucets
Nouveaux robinets électroniques



Disponible en Marzo de 2019
Available in March 2019 / Disponible en Mars 2019

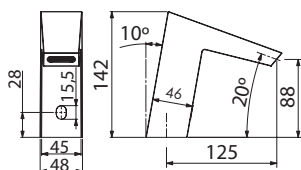

PLATINUM

LAVABO ELECTRÓNICO 90 - 1 AGUA
SENSOR TAP 90 - 1 water
LAVABO ÉLECTRONIQUE 90 - Robinet 1 eau

Grifo repisa para lavabo con aireador.
Caja (60741) y flexibles incluidos.
Basin Mixer with aerator. Box (60741) and flexible included.
Mitigeur lavabo avec aérateur. Boîte (60741) et flexible inclus.

Ref.	€	📦
60739	330,00	-

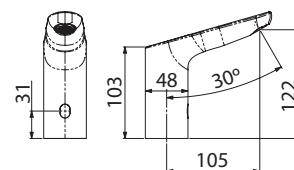

elegance

LAVABO ELECTRÓNICO 120 - 1 AGUA
SENSOR TAP 120 - 1 water
LAVABO ÉLECTRONIQUE 120 - Robinet 1 eau

Grifo repisa para lavabo con aireador.
Caja (60741) y flexibles incluidos.
Basin Mixer with aerator. Box (60741) and flexible included.
Mitigeur lavabo avec aérateur. Boîte (60741) et flexible inclus.

Ref.	€	📦
60740	290,00	-



12 cm
Distancia de detección
Détection distance / Distance de détection



Sensor antivandálico.
Bloqueo del suministro de agua a los 55 segundos.
Anti-vandalism sensor. Blocking the water supply at 55 seconds.
Capteur anti-vandalisme. Blocage de l'approvisionnement en eau à 55 secondes.

Aireador antivandálico.
Se requiere herramienta especial para su desmontaje.
Anti-vandal aerator. Special tool is required for dismantling.
Aérateur anti-vandalisme. Un outil spécial est nécessaire pour le démontage.

0,5 a 8 bar
7,3 a 116 psi
Presión de trabajo

Working pressure / Pression de travail

-20 a 70

Temp. de almacenamiento
Storage temperature
Température de stockage

15 a 50

Temp. de funcionamiento
Operating temperature
Température de fonctionnement

Mejora importante de la higiene y el confort

Important improvement of hygiene and comfort
Amélioration significative de l'hygiène et du confort

COLECTIVIDADES

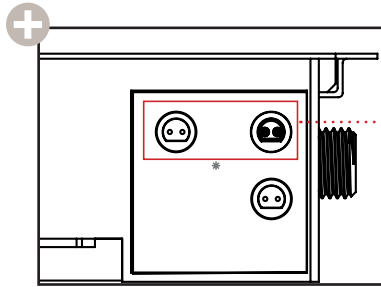

Conexiones del sensor del grifo
Sensor tap connection / Connexion
du robinet du capteur

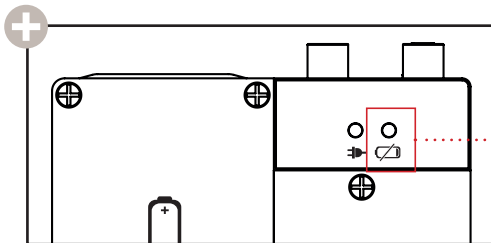

Indicador LED
Led indicators / Indicateurs led

Cuando se está agotando la batería se enciende un led intermitente de COLOR ROJO.

When the battery is running low, an intermittent RED COLOR led lights up.

Lorsque la batterie est faible, une led intermittente de COULEUR ROUGE s'allume.

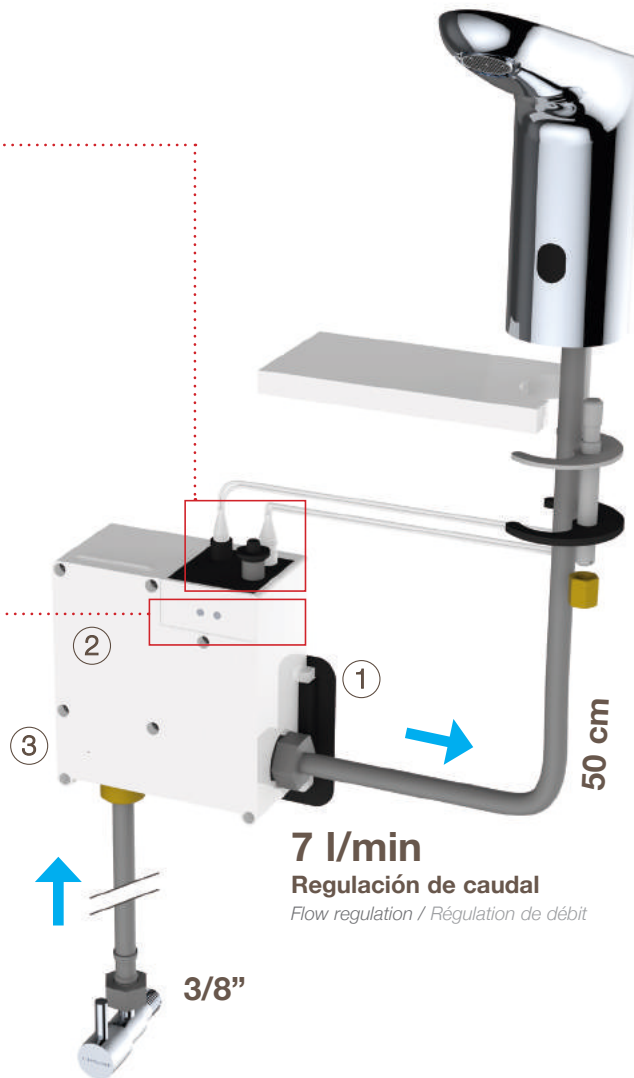

7 l/min
Regulación de caudal
Flow regulation / Régulation de débit

Instalación y mantenimiento

Installation and maintenance / Installation et maintenance

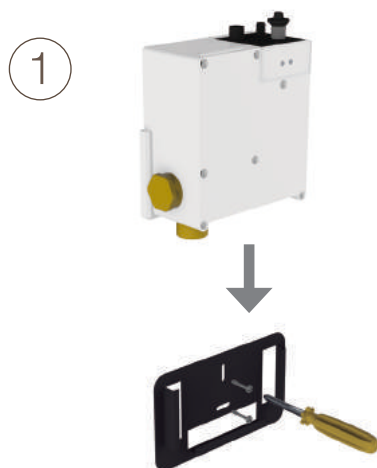

Sujeción caja pared
Wall box fixing / Fixation de la boîte murale

✓ **Platina sujeción caja pared incluida**
Enclosure wall box included / Boîtier mural inclus

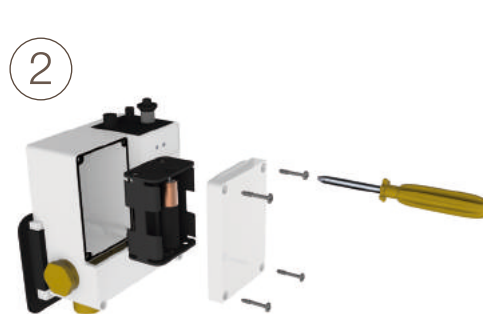

Cambio de pilas
Change the batteries / Changement de piles

✓ **6xAA (no incluidas)**
6xAA (not included) / 6xAA (non inclus)

✓ **Se recomienda utilizar pilas alcalinas.**
It is recommended to use alkaline batteries.
Il est recommandé d'utiliser des piles alcalines.

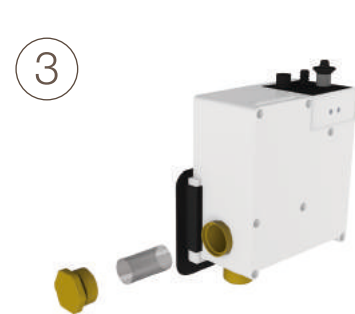

Limpieza de filtro
Filter cleaning / Nettoyage du filtre

✓ **Es necesario cortar la llave de paso para realizar la limpieza del filtro.**
It is necessary to cut off the stopcock to clean the filter. / Il est nécessaire de fermer le robinet d'arrêt pour nettoyer le filtre.

Recambios *Spare parts / Pièces de rechange*

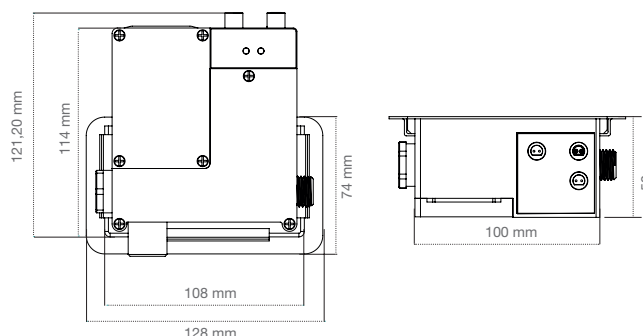

CAJA ESTÁNDAR STANDARD BOX BOÎTE STANDARD

Caja estándar con platina sujeción pared incluida.
Standard box with enclosure wall included.
Boîtier standard avec platine de fixation murale incluse.

Ref.	€	📦
60741	105,00	-



CAJA ESTÁNDAR

Standard box / Boîte standard

La caja estándar es una solución fácil de instalar con la integración de varios componentes de automatización en una caja compacta.

La instalación es práctica, rápida y estética.

*The standard box is an easy solution to install with the integration of several automation components in a compact box.
The installation is practical, fast and esthetic.*

La boîte standard est un boîtier compact intégrant plusieurs composants automatisés. Installation facile et rapide, pour un résultat très esthétique.

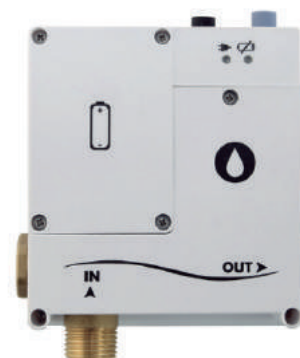

Características <i>Features / Caractéristiques</i>	6 V
Pila <i>Battery / Pile</i>	6xAA
Dimensiones <i>Dimensions / Dimensions</i>	110 x 100 x 53 mm

Protección <i>Protection / Protection</i>	IP67
Material de la caja <i>Box material / Matériel de la boîte</i>	ABS blanco <i>White / Blanc</i>

Opción de uso con fuente de alimentación

Option of use with power supply

Option d'utilisation avec alimentation



COLECTIVIDADES

Recambios Spare parts / Pièces de rechange

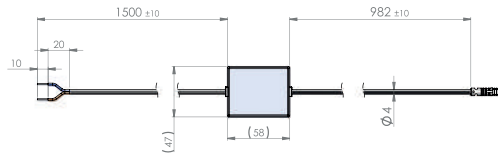

EN 15091 CJ/T194 CE

Cumplimiento estándar

Standard compliance
Conformité aux normes

**ALIMENTACIÓN CORRIENTE
POWER SUPPLY
CÂBLE D'ALIMENTATION**

250 cm

Ref.	€	
60742	69,00	-

Conexión corriente

Current connection
Connexion au courant électrique

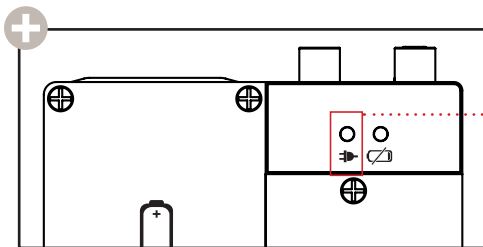
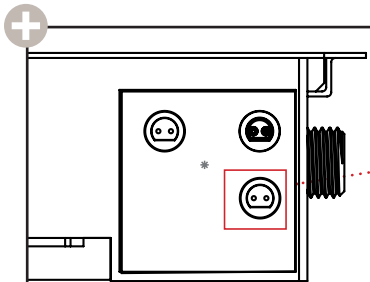
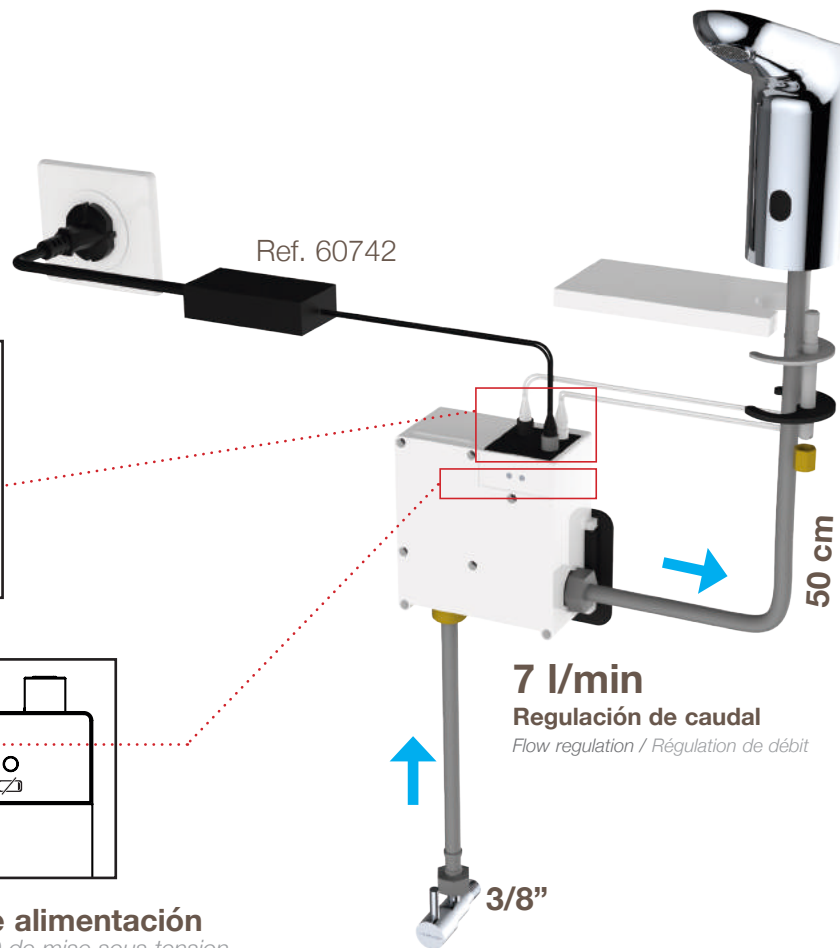

Indicador LED fuente de alimentación

Power supply led / Indicateur LED de mise sous tension.

Si se conecta a la corriente el led VERDE queda siempre encendido.
Aunque utilicemos la opción de corriente, se necesita tener las pilas colocadas. En caso de corte eléctrico sigue funcionando con pilas.

If it is connected to the power, the GREEN LED is always on.
Even if we use the current option, you need to have the batteries in its place. In case of power failure, it continues working with the batteries.

Si le boîtier est connecté au courant électrique, le voyant LED de couleur verte reste allumé en permanence.
Il est recommandé de laisser les piles installées même si votre appareil est branché sur le courant électrique, afin qu'en cas de coupure de courant, votre robinetterie continue à fonctionner.

Presión de trabajo Working pressure / Pression de travail	0,5 a 8 bar 7,3 a 116 psi
Temp. de almacenamiento Storage temperature Température de stockage	-20 a 70
Temp. de funcionamiento Operating temperature Température de fonctionnement	15 a 50

Ducha higiénica Shattaf Douche hygiénique

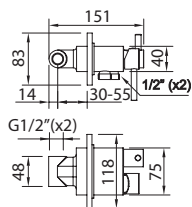
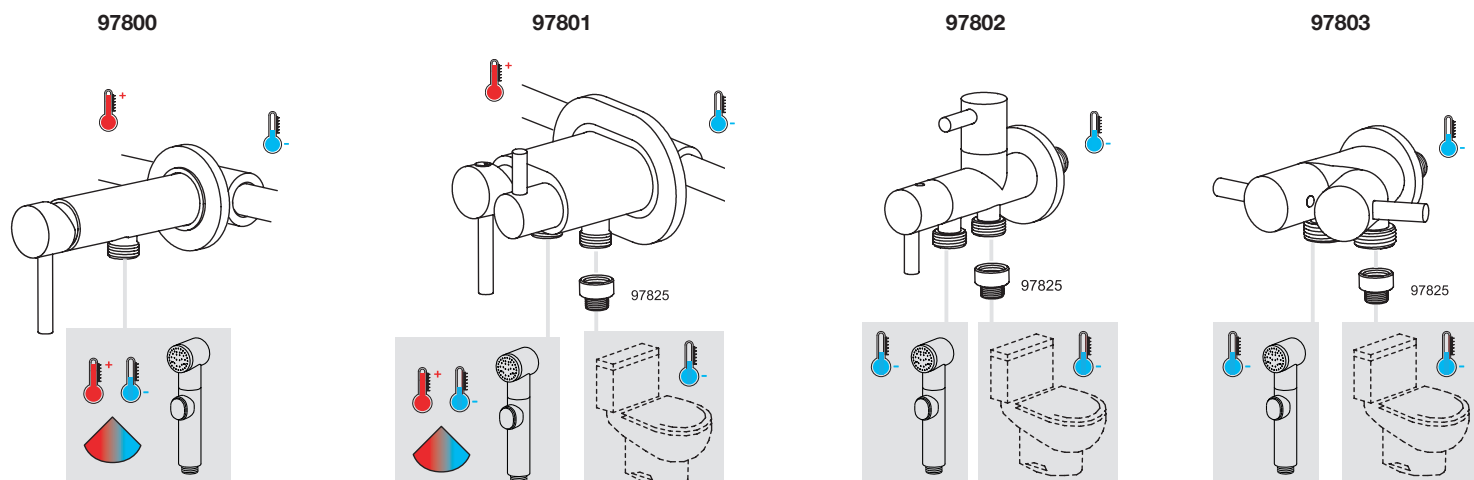

SHATTAF TOUAREG

Mezclador empotrado para ducha higiénica con salida cisterna.
Wall mounted single mixer shattaf with water tank outlet.
Mitigeur mural pour douchette hygiénique et sortie réservoir de chasse d'eau

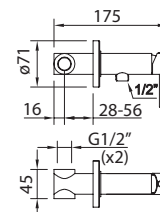

SHATTAF ATLAS

Mezclador empotrado para ducha higiénica.
Wall mounted single mixer shattaf.
Mitigeur mural pour douchette hygiénique



Ref.	€	Q	Incluye Includes Inklus
97801	114,00	6	96136 1,20m Inox 97822 97823 97824 1/2" F-3/8" M 97825 98988

Ref.	€	Q	Incluye Includes Inklus
97800	86,00	6	96136 1,20m Inox 97822 97824 98988

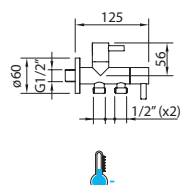

SHATTAF CAMEL

Válvula para ducha higiénica con salida cisterna.
Shattaf bidet spray with water tank outlet.
Robinet pour douchette hygiénique et sortie réservoir de chasse d'eau



Ref.	€	Q	Incluye Includes Inklus
97802	64,00	6	96136 1,20m Inox 97823 1/2" F-3/8" M 97825 98988

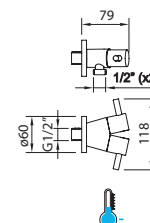

SHATTAF OASIS

Válvula para ducha higiénica con salida cisterna.
Shattaf bidet spray with water tank outlet.
Robinet pour douchette hygiénique et sortie réservoir de chasse d'eau



Ref.	€	Q	Incluye Includes Inklus
97803	59,00	6	96136 1,20m Inox 97823 1/2" F-3/8" M 97825 98988

COLECTIVIDADES



SHATTAF SAHARA

Válvula para ducha higiénica con soporte integrado.
Shattaf with support included.
Robinet pour douchette hygiénique avec support intégré

Ref.	€	📦
98442	52,00	10

Incluye Includes Inclus  
 96136 1,20m Inox



SHATTAF KIRA

Ducha higiénica latón.
Brass hygienic handshower
Douchette hygiénique laiton

Ref.	€	📦
98799	36,00	50

Incluye Includes Inclus  
 98988 1,20m Inox 97816



SHATTAF NINA

Ducha higiénica latón.
Brass hygienic handshower
Douchette hygiénique laiton

Ref.	€	📦
98798	34,00	50

Incluye Includes Inclus  
 98988 1,20m Inox 97816



HIGIÉNICA

Hygienic handshower / Douchette hygiénique

Ducha higiénica, ABS.
Hygienic handshower , ABS.
Douchette hygiénique ,ABS.

Ref.	€	📦
96136	25,00	20

Incluye Includes Inclus 
 1,20m Inox 97816

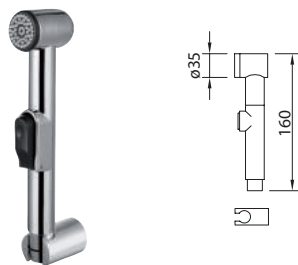

SAHEL HIGIÉNICA

Hygienic handshower / Douchette hygiénique

Ducha higiénica, ABS.
Hygienic handshower , ABS.
Douchette hygiénique ,ABS.

Ref.	€	📦
97809	17,00	20

Incluye Includes Inclus  
 98988 1,20m Inox 97816



HIGIÉNICA

Hygienic handshower / Douchette hygiénique

Ducha higiénica, ABS.
Hygienic handshower , ABS.
Douchette hygiénique ,ABS.

Ref.	€	📦
97740	28,00	50

Incluye Includes Inclus  
 98988 1,50m plastificado

Grifos individuales

Cold water taps
Lave-main

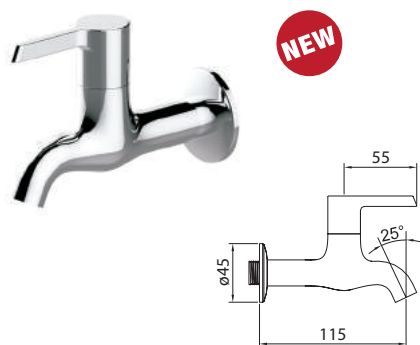

DESIGN

GRIFERÍA SIMPLE MURAL Wall mounted single tap Robinet simple mural

Grifo de pared
Wall mounted single tap.
Robinet

Ref.	€	📦
60696	23,00	-



DESIGN

GRIFERÍA DE FREGADERO Y LAVADERO DE PARED Wall mounted sink and washing-machine tap Lave-main

Grifo de pared salida fregadero / lavadero / lavadora.
Wall mounted single tap.
Robinet, aérateur

Ref.	€	📦
60697	35,00	-



DESIGN

GRIFERÍA DE FREGADERO Y LAVADERO Sink and washing-machine tap Lave-main

Grifo de pared . Salida 1/2" + accesorio manguera.
Wall mounted single tap. 1/2" outlet + hose fitting.
Robinet mural. Sortie 1/2" + raccord pour tuyau

Ref.	€	📦
60698	26,00	-



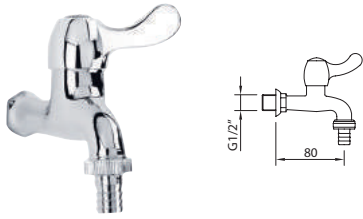

GRIFERÍA DE FREGADERO Y LAVADERO
Sink and washing-machine tap
Lave-main

Grifo de pared. Accesorio manguera.
Wall mounted single tap. Hose fitting.
Robinet, aérateur. Raccord pour tuyau.

Ref.	€	📦
96133	17,00	96



96234



START elegance

GRIFO SIMPLE DE PARED
Single washbain wall tap
Lave-main

Grifo mural con aireador.
Wall single basin tap, with aerator.
Robinet, aérateur

Ref.	€	📦
ACS 99393	27,00	12



96202 96208

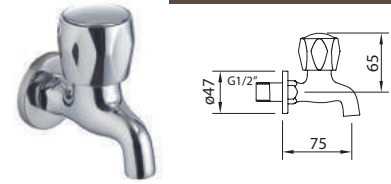

WITH2 guayama

GRIFERÍA SIMPLE MURAL
Wall mounted single tap
Robinet simple mural

Grifo mural con aireador, índice de agua fría.
Wall mounted single basin faucet, with aerator, cold water index.
Robinet, aérateur

Ref.	€	📦
ACS 98451	28,00	72



96232 96208

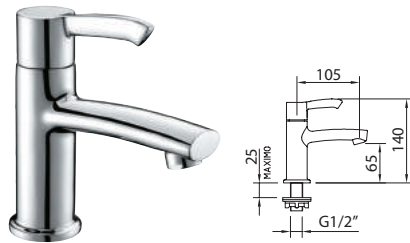

GRIFO SIMPLE PARA LAVABO
Single washbain tap | Lave-main

Grifo de repisa con aireador.
Deck mounted single basin tap, with aerator.
Robinet, aérateur

Ref.	€	📦
98448	60,00	10

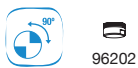

96202



GRIFO SIMPLE PARA LAVABO
Single washbain tap | Lave-main

Grifo de repisa con aireador.
Deck mounted single basin tap, with aerator.
Robinet, aérateur

Ref.	€	📦
96134	32,00	24



96234 90025



START elegance

GRIFO SIMPLE PARA LAVABO
Single washbain tap | Lave-main

Grifo de repisa con aireador.
Deck mounted single basin tap, with aerator.
Robinet, aérateur

Ref.	€	📦
ACS 99392	34,00	12



96202 96208



S12 urban

GRIFO SIMPLE PARA LAVABO
Single washbain tap | Lave-main

Grifo de repisa con aireador.
Deck mounted single basin tap, with aerator.
Robinet, aérateur

Ref.	€	📦
98449	27,00	24



96202 96208



PANAM urban

GRIFO SIMPLE PARA LAVABO
Single washbain tap | Lave-main

Grifo de repisa con aireador.
Deck mounted single basin tap, with aerator.
Robinet, aérateur

Ref.	€	📦
98458	27,00	48



96202 96208

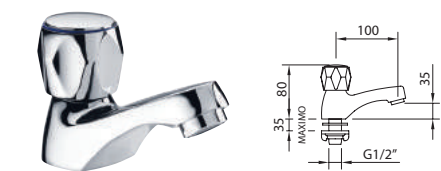

WITH2 guayama

GRIFERÍA SIMPLE REPISA 35
Single tap 35 | Robinet simple 35

Grifo de repisa, con aireador, índice de agua fría.
Deck mounted single basin faucet, with aerator, cold water indice.
Robinet, aérateur

Ref.	€	📦
ACS 96097	27,00	24



96232 96208 90025

Maneta gerontológica Medical lever operated P.M.R.

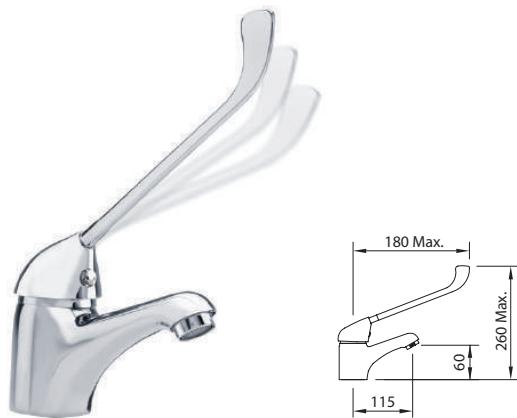

PANAM **urban**

LAVABO CON MANETA GERONTOLÓGICA
Basin mixer with medical lever
Mitigeur lavabo avec manette médicale

Mezclador con aireador, con palanca gerontológica y flexibles M-10 3/8" x 370 mm.
 Mixer with medical lever operated with aerator, flexible hoses M-10 3/8" x 370 mm.
 Mitigeur lavabo, manette médicale, aérateur, raccords flexibles M-10 3/8" x 370 mm

	Ref.	€	📦
	94694	61,00	12

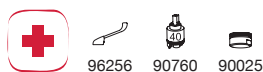

PANAM **urban**

FREGADERO MURAL CON MANETA GERONTOLÓGICA
Wall mounted sink mixer with medical lever
Mitigeur évier mural, avec manette médicale

Mezclador mural con aireador, con palanca gerontológica y caño giratorio inferior.
 Wall mounted mixer with medical lever operated with aerator, flower swivel spout
 Mitigeur évier mural, manette médicale, bec orientable façonné, aérateur

	Ref.	€	📦
	97975	95,00	8

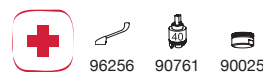

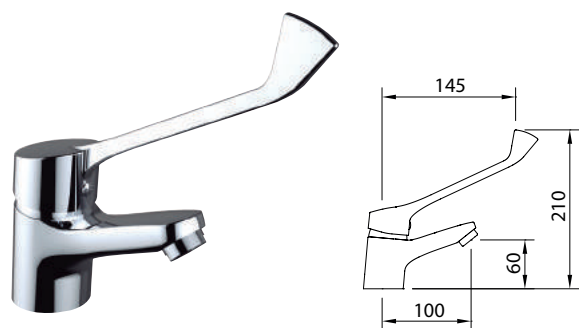

S12 urban

LAVABO CON MANETA GERONTOLÓGICA

Basin mixer with medical lever

Mitigeur lavabo avec manette médicale

Mezclador con aireador, con palanca gerontológica y flexibles M-10 3/8" x 370 mm.

Mixer with medical lever operated with aerator, flexible hoses M-10 3/8" x 370 mm.

Mitigeur lavabo, manette médicale, aérateur, raccords flexibles M-10 3/8" x 370 mm

	Ref.	€	📦
	99214	61,00	8

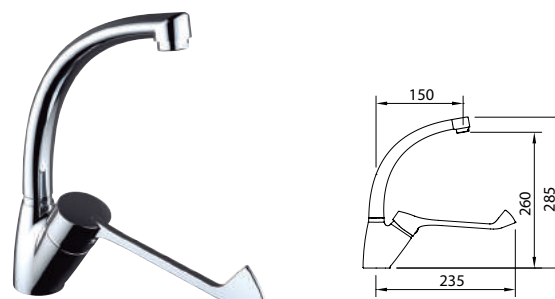

S12 urban

FREGADERO CON MANETA GERONTOLÓGICA

Wall mounted sink mixer with medical lever

Mitigeur évier mural, avec manette médicale

Fregadero con maneta gerontológica con mezclador con aireador y flexibles M-10 3/8" x 370 mm con palanca gerontológica.

Sink mixer with medical lever with mixer, with medical lever operated with aerator, flexible hoses M-10 3/8" x 370 mm.

Mitigeur évier, manette médicale, bec orientable façonné, aérateur, raccords flexibles M-10 3/8" x 370 mm

	Ref.	€	📦
	99215	85,00	8

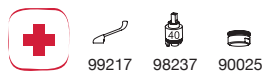

S12 urban

FREGADERO MURAL CON MANETA GERONTOLÓGICA

Wall mounted sink mixer with medical lever

Mitigeur évier mural avec manette médicale

Mezclador mural con aireador, con palanca gerontológica y caño giratorio inferior.

Wall mounted mixer with medical lever operated with aerator, flower swivel spout

Mitigeur évier mural, manette médicale, bec orientable façonné, aérateur

	Ref.	€	📦
	99216	99,00	12





TERMOSTÁTICOS

Clever en tu sala de baño

Clever in your bathroom
Clever dans votre salle de bain



Termostáticos
Thermostatics
Termostatiques
278

Termostáticos

Thermostatics
Thermostatiques

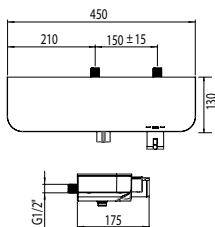

NINE elegance

DUCHA TERMOSTÁTICA
Thermostatic shower mixer
Mitigeur douche thermostatique

Incluye teléfono ducha, flexo y soporte
Includes handset, hose and holder
Inclus douchette, flexible et support
(99611, 98880, 60311)

Sin kit ducha
Without shower kit
Sans kit de douche

Ref.	€	📦
60154	383,00	4
60761	352,00	4

Más información More information Plus d'informations Pág. 45

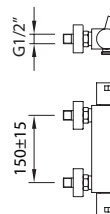

BIMINI

DUCHA TERMOSTÁTICA
Thermostatic Shower mixer | Douche thermostatique

Incluye teléfono ducha, flexo y soporte
Includes handset, hose and holder
Inclus douchette, flexible et support
(96412, 97114, 97112)

Sin kit ducha
Without shower kit
Sans kit de douche

Ref.	€	📦
96490	345,00	6
98153	314,00	6

Más información More information Plus d'informations Pág. 31

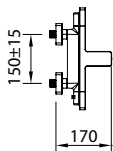

NINE Xtreme

BAÑO-DUCHA TERMOSTÁTICO
Thermostatic bath-shower mixer | Mitigeur bain-douche thermostatique

Incluye teléfono ducha, flexo y soporte
Includes handset, hose and holder
Inclus douchette, flexible et support
(98880-99609-60311)

Sin kit ducha
Without shower kit
Sans kit de douche

Ref.	€	📦
60131	342,00	6
60132	311,00	6

Inversor incorporado en la maneta de caudal
Integral diverter in the flow handle
Inverseur intégré dans la poignée

Más información More information Plus d'informations Pág. 49

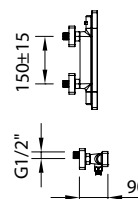

NINE Xtreme

DUCHA TERMOSTÁTICA
Thermostatic shower mixer | Mitigeur douche thermostatique

Incluye teléfono ducha, flexo y soporte
Includes handset, hose and holder
Inclus douchette, flexible et support
(98880-99609-60311)

Sin kit ducha
Without shower kit
Sans kit de douche

Ref.	€	📦
60133	290,00	6
60134	259,00	6

Más información More information Plus d'informations Pág. 49

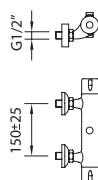

NINE Urban

GRIFERÍA PARA DUCHA TUBO EXTENSIBLE
Shower mixer for adjustable shower bar
Mitigeur douche thermostatique double sortie

Sin kit ducha
Without shower set
Sans kit de douche

Ref.	€	📦
98763	174,00	6

Inversor incorporado en la maneta de caudal
Integral diverter in the flow handle
Inverseur intégré dans la poignée

Más información More information Plus d'informations Pág. 143

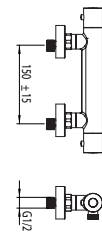

NINE URBAN SLIM

DUCHA TERMOSTÁTICA
Thermostatic shower mixer
Mitigeur douche thermostatique

Incluye teléfono ducha, flexo y soporte
Includes handset, hose and holder
Inclus douchette, flexible et support
(98342, 97670, 98343)

Sin kit ducha
Without shower set
Sans kit de douche

Ref.	€	📦
60414	158,00	6
60415	143,00	6

Más información More information Plus d'informations Pág. 140

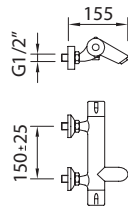

NINE urban

BAÑO-DUCHA TERMOSTÁTICO

Thermostatic bath-shower mixer | Mitigeur bain-douche thermostatique

Incluye teléfono ducha, flexo y soporte
Includes handset, hose and holder
Inclus douchette, flexible et support
(96108, 97670, 98208)

Sin kit ducha
Without shower kit
Sans kit de douche

Ref.	€	
98823	218,00	6
98929	203,00	6

Inversor incorporado en la maneta de caudal
Integral diverter in the flow handle
Inverseur intégré dans la poignée

Más información More information Plus d'informations Pág. 141

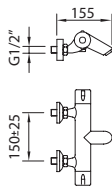

NINE urban

BAÑO-DUCHA TERMOSTÁTICO

Thermostatic bath-shower mixer
Mitigeur bain-douche thermostatique

Incluye teléfono ducha, flexo y soporte
Includes handset, hose and holder
Inclus douchette, flexible et support
(96108, 97670, 90011)

Sin kit ducha
Without shower set
Sans kit de douche

Ref.	€	
98822	203,00	6
98928	188,00	6

Inversor incorporado en la maneta de caudal
Integral diverter in the flow handle
Inverseur intégré dans la poignée

Más información More information Plus d'informations Pág. 141

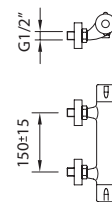
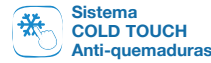

NINE urban

DUCHA TERMOSTÁTICA

Thermostatic shower mixer | Mitigeur douche thermostatique

Incluye teléfono ducha, flexo y soporte
Includes handset, hose and holder
Inclus douchette, flexible et support
(96108, 97670, 98208)

Sin kit ducha
Without shower kit
Sans kit de douche

Ref.	€	
98478	184,00	6
98149	169,00	6

Más información More information Plus d'informations Pág. 141

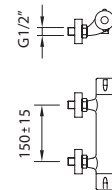

NINE urban

DUCHA TERMOSTÁTICA

Thermostatic shower mixer | Mitigeur douche thermostatique

Incluye teléfono ducha, flexo y soporte
Includes handset, hose and holder
Inclus douchette, flexible et support
(96108, 97670, 90011)

Sin kit ducha
Without shower set
Sans kit de douche

Ref.	€	
60325	169,00	-
60326	154,00	-

Más información More information Plus d'informations Pág. 141



Termostáticos extensibles
Adjustable thermostatics
Thermostatiques extensibles
284

Sistemas de ducha y baño- ducha

Shower and bath-shower systems Colonnes douche et bain-douche



Termostáticos no extensibles
Non-adjustable thermostatics
Thermostatiques non extensibles
286



Monomandos extensibles
Adjustable single lever
Mitigeurs extensibles
288



Bimandos extensibles
Adjustable two handles
Mélangeurs extensibles
290



Monomandos no extensibles
Non-adjustable single lever
Mitigeurs non extensibles
290

Sistemas de ducha y baño ducha

Shower and bath-shower systems

Colonne douche et bain-douche

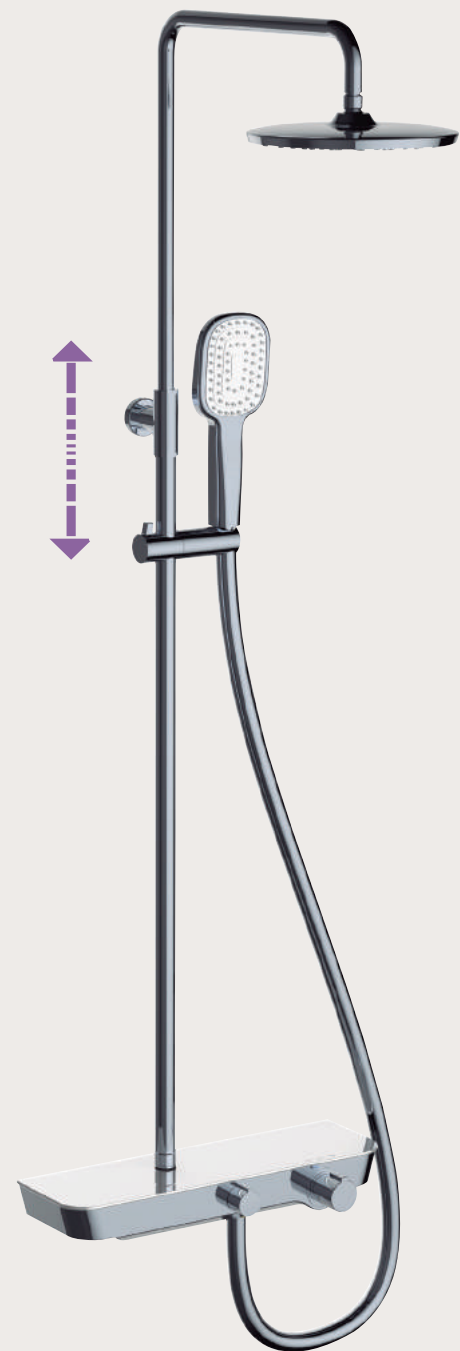

NINE elegance

Termostáticos extensibles
Adjustable thermostatics
Thermostatiques extensibles



NINE Xtreme



NINE urban 

Sistemas de ducha y baño-ducha

Shower and bath-shower systems
Colonne douche et bain-douche

TERMOSTÁTICOS EXTENSIBLES

ADJUSTABLE THERMOSTATICS / THERMOSTATIQUES EXTENSIBLES

BIMINI

CONJUNTO DE BAÑO-DUCHA TERMOSTÁTICO EXTENSIBLE
Extensible Thermostatic bath-shower system
Colonne thermostatique bain-douche extensible

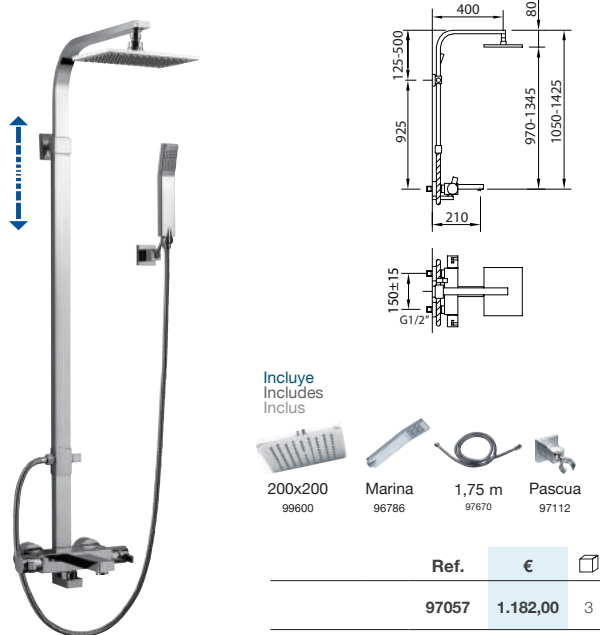

Más información Pág. 33
More information / Plus d'informations

Inversor incorporado en la maneta de caudal
Diverter built in the flow handle
Inverseur intégré dans la poignée

BIMINI

CONJUNTO DE DUCHA TERMOSTÁTICO EXTENSIBLE
Extensible Thermostatic shower system
Colonne thermostatique douche extensible

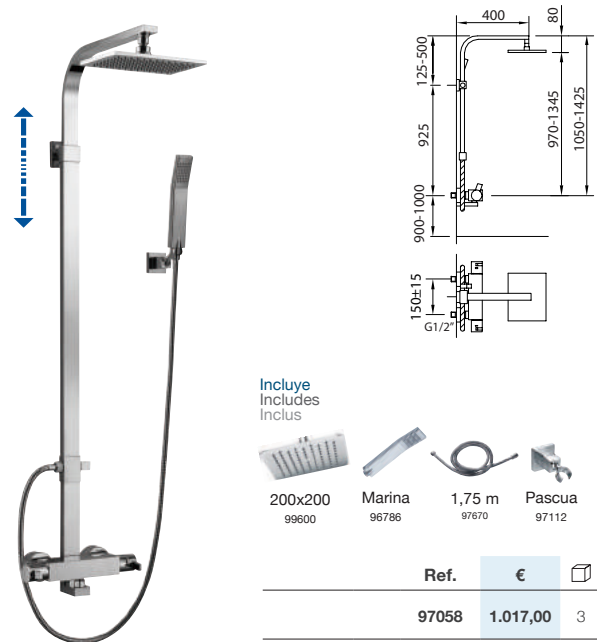

Más información Pág. 33
More information / Plus d'informations

NINE elegance

CONJUNTO DE DUCHA EXTENSIBLE TERMOSTÁTICO
Thermostatic Extensible shower system
Colonne mélangeur douche extensible thermostatique

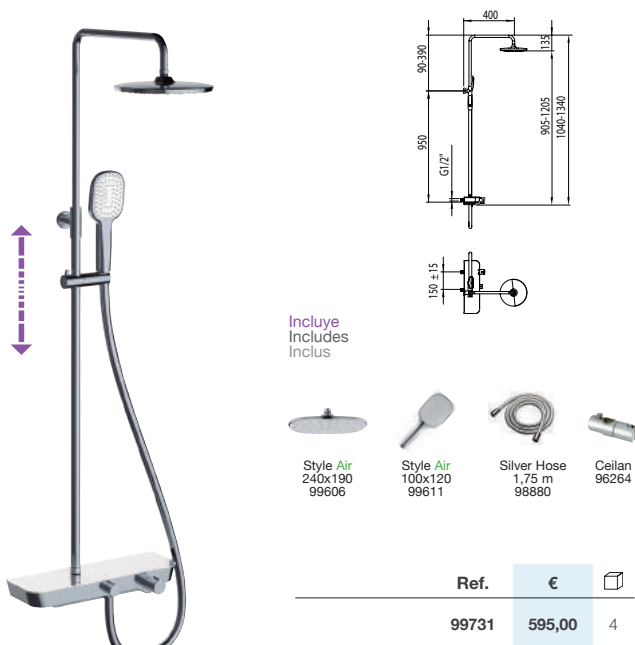

Más información Pág. 45
More information / Plus d'informations

Inversor incorporado en la maneta de caudal
Diverter built in the flow handle
Inverseur intégré dans la poignée

NINE xtreme

CONJUNTO DE DUCHA EXTENSIBLE TERMOSTÁTICO
Thermostatic Extensible shower system
Colonne mélangeur douche extensible thermostatique

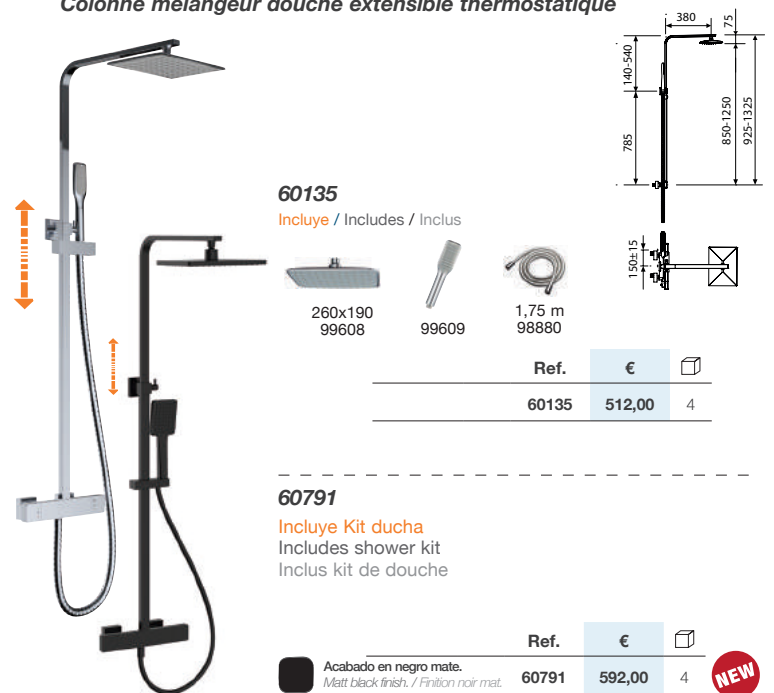

Más información Pág. 48
More information / Plus d'informations

Inversor incorporado en la maneta de caudal
Diverter built in the flow handle
Inverseur intégré dans la poignée

NINE urban

CONJUNTO DE BAÑO-DUCHA TERMOSTÁTICO
Thermostatic bath-shower system
Colonne thermostatique bain-douche extensible



Incluye
Includes
Inclus

- Circular 98518
- Caiman 90796
- 1,75 m 97670
- Ceilan 96264
- Support 98497
- Antao 96120

Ref.	€	
98640	466,00	4

Más información Pág. 145
More information / Plus d'informations

NINE urban

CONJUNTO DE DUCHA TERMOSTÁTICO
Thermostatic shower system
Colonne thermostatique douche extensible



Incluye
Includes
Inclus

- Circular 98518
- Tanganyka 5F 97994
- 1,75 m 97670
- Ceilan 96264
- Support 98497

Inversor incorporado en la maneta de caudal
Diverter built in the flow handle
Inverseur intégré dans la poignée

Ref.	€	
60327	431,00	-

Más información Pág. 143
More information / Plus d'informations

WITH2 antigua

CONJUNTO DE DUCHA TERMOSTÁTICO EXTENSIBLE
Extensible Thermostatic shower system
Colonne thermostatique douche extensible



Incluye
Includes
Inclus

- New Tampa 96437
- Antigona 90758
- 1,75 m 97670
- Antigona 96159
- Support 98497
- Antao 96120

Ref.	€	
96746	576,00	3

Más información Pág. 76
More information / Plus d'informations

CIRCULAR THERM BOX

CONJUNTO DE DUCHA TERMOSTÁTICO EXTENSIBLE
Adjustable thermostatic shower system
Colonne thermostatique douche extensible



Incluye
Includes
Inclus

- Circular 98518
- Tanganyka 5F 97994
- 1,75 m 97670
- Ceilan ø25 96264
- Support 98497

Inversor incorporado en la maneta de caudal
Diverter built in the flow handle
Inverseur intégré dans la poignée

* (Pack indivisible de 4 unidades)
(Indivisible packaging of 4 units)
(Pack indivisible de 4 unités)

Ref.	€	
60412	420,00	4

Más información Pág. 241
More information / Plus d'informations

Sistemas de ducha y baño-ducha

Shower and bath-shower systems
Colonne douche et bain-douche

TERMOSTÁTICOS NO EXTENSIBLES

NON-ADJUSTABLE THERMOSTATICS / THERMOSTATIQUES NON EXTENSIBLES

CAIMAN elegance

CONJUNTO DE DUCHA TERMOSTÁTICO 4 JETS

Thermostatic shower system 4 jets

Colonne thermostatique douche hydromassage

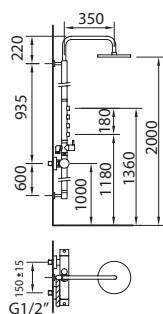

Incluye
Includes
Inclus



Ø200
99637



Caiman
90796



1,80 m
97114

Ref.	€	Q
96436	1.113,00	4

Más información Pág. 67
More information / Plus d'informations

WITH2 morea

CONJUNTO DE DUCHA TERMOSTÁTICO 4 JETS

Thermostatic shower system 4 jets

Colonne thermostatique douche hydromassage

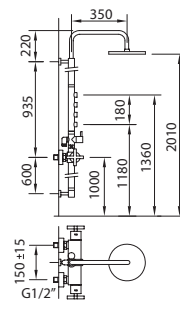

Incluye
Includes
Inclus



Ø200
97109



Caiman
90796



1,80 m
97114

Ref.	€	Q
97018	1.113,00	4

Más información Pág. 80
More information / Plus d'informations

KUADRAT THERM BOX

CONJUNTO DE DUCHA TERMOSTÁTICO

Thermostatic shower system

Colonne thermostatique douche

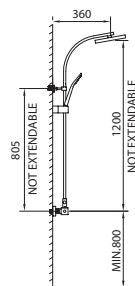

Incluye
Includes
Inclus



Kube
98672



Marina
96786



1,75 m
97670



Saona
96413

Ref.	€	Q
98671	595,00	4*

*(Pack indivisible de 4 unidades)
(Indivisible packaging of 4 units)
(Pack indivisible de 4 unités)

Más información Pág. 240
More information / Plus d'informations

CIRCULAR THERM BOX

CONJUNTO DE DUCHA TERMOSTÁTICO

Thermostatic shower system

Colonne thermostatique douche

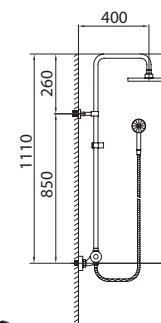

Incluye
Includes
Inclus



Circular
98518



Syvari 3F
98884



1,75 m
97670



ø20
98997



Support
98998

Inversor incorporado en la maneta de caudal
Diverter built in the flow handle
Inverseur intégré dans la poignée

Ref.	€	Q
60413	389,00	4*

*(Pack indivisible de 4 unidades)
(Indivisible packaging of 4 units)(Pack indivisible de 4 unités)

Más información Pág. 241
More information / Plus d'informations

NINE urban

CONJUNTO DE DUCHA TERMOSTÁTICO

*Thermostatic shower system
Colonne thermostatique douche*

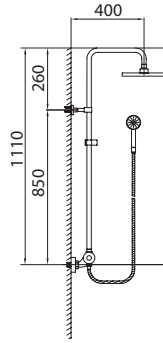

Incluye
Includes
Inclus



Circular
98518



ø20
98997



Syvari 3F
98884



1.75 m
97670



Support
98998

Inversor incorporado en la
maneta de caudal
*Diverter built in the flow handle
Inverseur intégré dans la poignée*

Ref.	€	
60328	400,00	1

Más información Pág. 144
More information / Plus d'informations

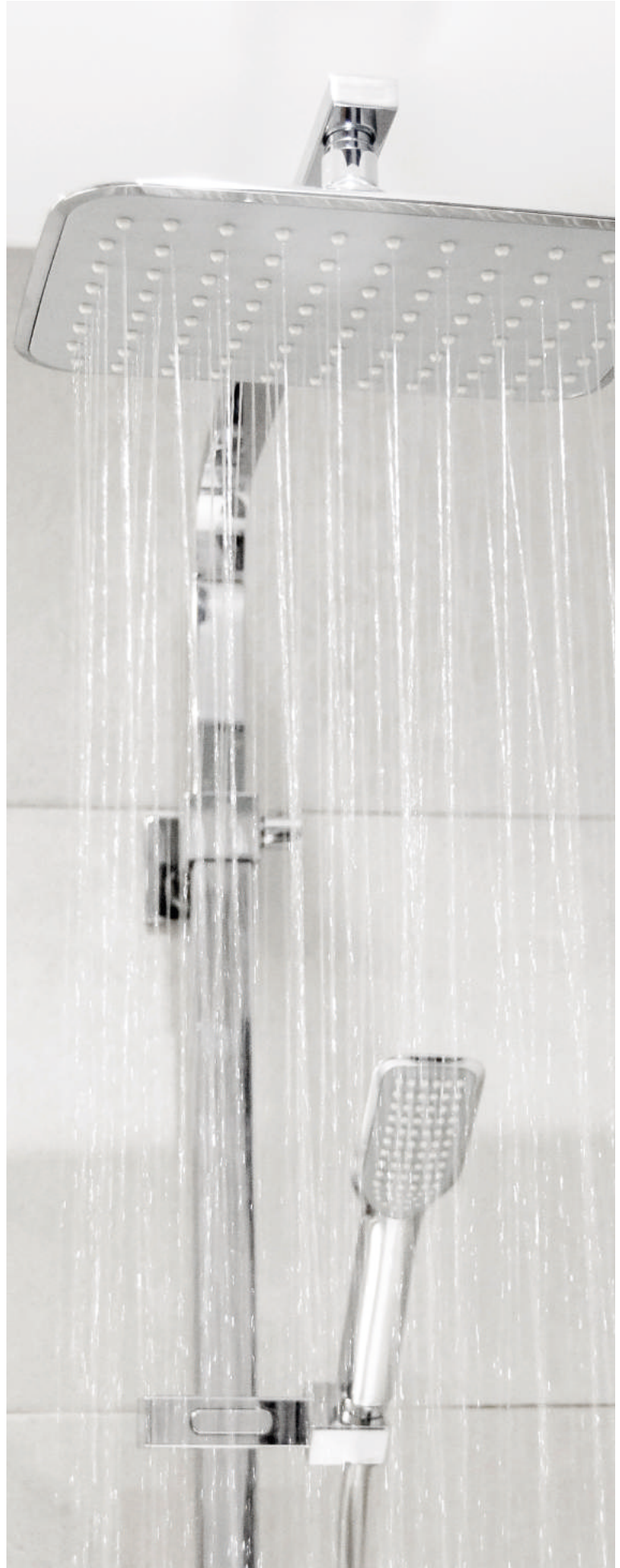

Sistemas de ducha y baño-ducha

Shower and bath-shower systems
Colonne douche et bain-douche

MONOMANDOS EXTENSIBLES ADJUSTABLE SINGLE LEVERS / MITIGEURS EXTENSIBLES

BIMINI

CONJUNTO BAÑO-DUCHA EXTENSIBLE
Extensible bath-shower system
Colonne mitigeur bain-douche extensible

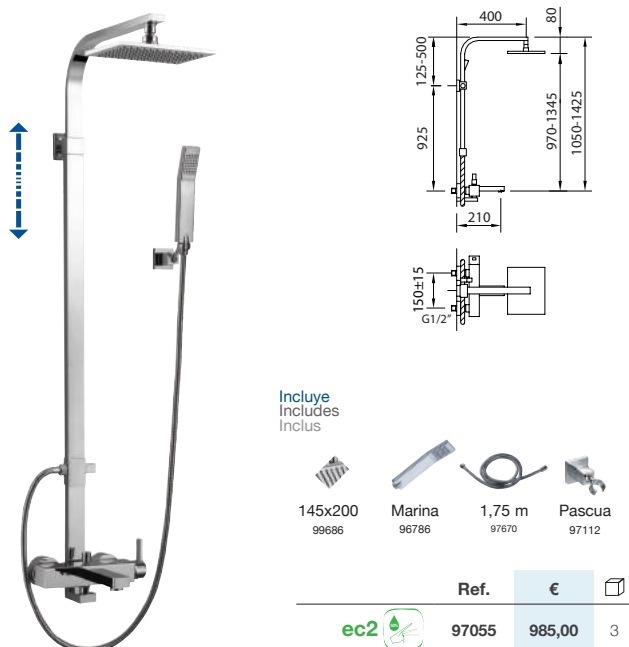

Más información Pág. 32
More information / Plus d'informations

BIMINI

CONJUNTO DE DUCHA EXTENSIBLE |
Extensible shower system |
Colonne mitigeur douche extensible

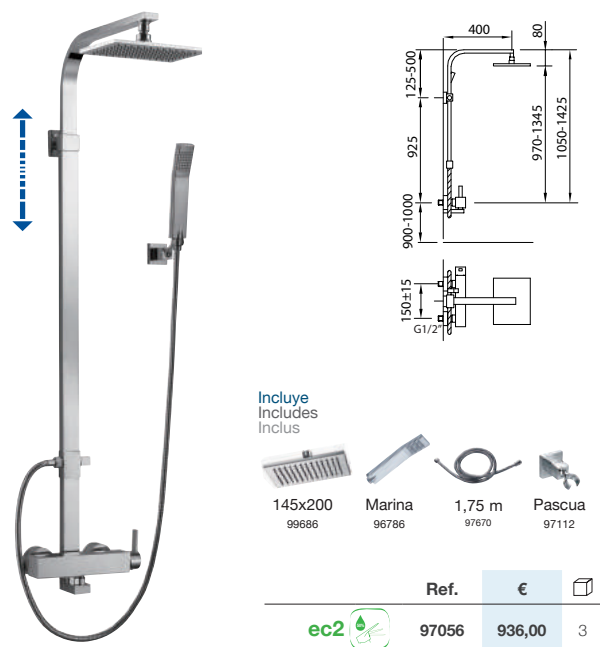

Más información Pág. 32
More information / Plus d'informations

PAULA

CONJUNTO DE DUCHA EXTENSIBLE
Shower system
Colonne mitigeur douche extensible

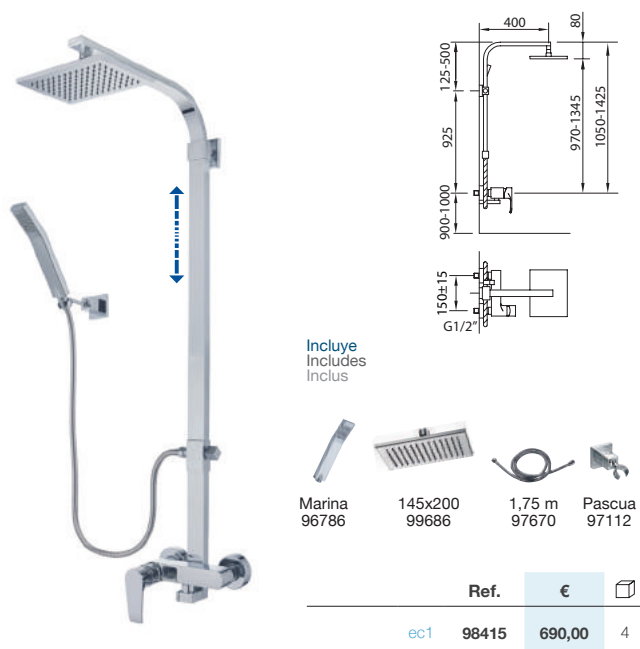

Más información Pág. 40
More information / Plus d'informations

START elegance

CONJUNTO DUCHA EXTENSIBLE
Extensible shower system
Colonne mitigeur bain-douche extensible

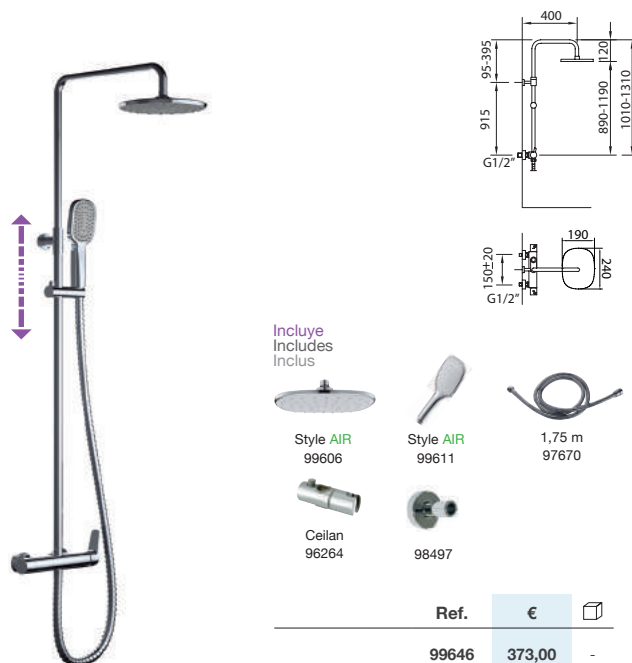

Más información Pág. 95
More information / Plus d'informations

Inversor incorporado en la maneta de caudal
Diverter built in the flow handle
Inverseur intégré dans la poignée

START Xtreme

CONJUNTO DUCHA EXTENSIBLE

Extensible shower system

Colonne mitigeur bain-douche extensible

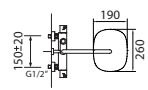
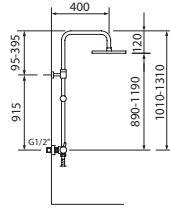

Incluye
Includes
Inclus



Trend
99608



Trend
99609



1,75 m
97670



Ceilan
96264



98497

Ref.	€	
ec3	99727	373,00

Inversor incorporado en la maneta de caudal
Diverter built in the flow handle
Inverseur intégré dans la poignée

Más información Pág. 98
More information / Plus d'informations

NINE elegance

CONJUNTO DE DUCHA EXTENSIBLE

Extensible shower system

Colonne mélangeur douche extensible

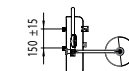
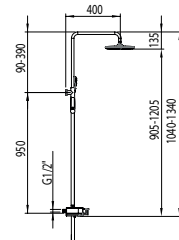

Incluye
Includes
Inclus



Style Air
240x190
99606



Style Air
100x120
99611



Silver Hose
1,75 m
98880



Ceilan
96264

Ref.	€	
99732	518,00	4

Inversor incorporado en la maneta de caudal
Diverter built in the flow handle
Inverseur intégré dans la poignée

Más información Pág. 44
More information / Plus d'informations

CIRCULAR MANUAL BOX

CONJUNTO DE DUCHA EXTENSIBLE

Adjustable shower system

Colonne mitigeur douche extensible

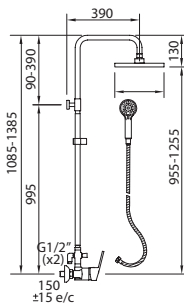

Incluye
Includes
Inclus



Circular
98518



Tanganyika 5F
97994



1,75 m
97670



Ceilan ø25
96264



Support
98497



Antao
96120

Ref.	€	
ec1	98527	320,00

Inversor incorporado en la maneta de caudal
Diverter built in the flow handle
Inverseur intégré dans la poignée

Más información Pág. 243
More information / Plus d'informations

S12 urban

CONJUNTO DE DUCHA

Shower system

Colonne mitigeur douche

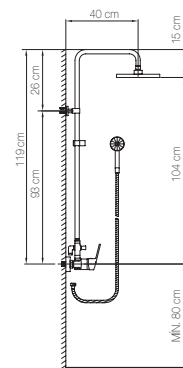

Incluye
Includes
Inclus



Circular
98518



Syvari 3F
98884



1,75 m
97670



ø20
98997



Support
98998



Antao
96120

⚠ NO EXTENSIBLE
NOT EXTENSIBLE
NON EXTENSIBLE

96175	98237	
-------	-------	--

Ref.	€	
ec1	99308	309,00

Más información Pág. 135
More information / Plus d'informations

Sistemas de ducha y baño-ducha

Shower and bath-shower systems
Colonnes douche et bain-douche

BIMANDOS EXTENSIBLES

ADJUSTABLE TWO HANDLES / MELANGEURS EXTENSIBLES

WITH2 antigona
CONJUNTO DE DUCHA EXTENSIBLE
Extensible shower system
Colonne mélangeur douche extensible



Incluye
Includes
Inclus

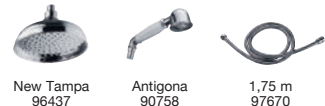
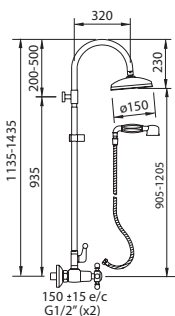

Ref.	€	Q
96154	455,00	3

Más información Pág. 77
More information / Plus d'informations

WITH2 antigona
CONJUNTO DE BAÑO-DUCHA EXTENSIBLE
Extensible bath-shower system
Colonne mélangeur bain-douche extensible



Incluye
Includes
Inclus

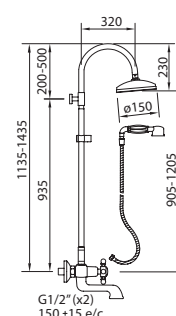

Ref.	€	Q
96747	500,00	3

Inversor incorporado en la maneta de caudal
Diverter built in the flow handle
Inverseur intégré dans la poignée

Más información Pág. 77
More information / Plus d'informations

MONOMANDOS NO EXTENSIBLES

NON-ADJUSTABLE SINGLE LEVERS / MITIGEURS NON EXTENSIBLES

KUADRAT MANUAL BOX
CONJUNTO DE DUCHA
Shower system
Colonne mitigeur douche



Incluye
Includes
Inclus

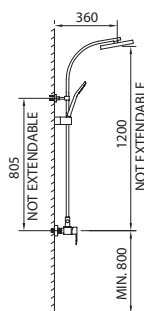

Ref.	€	Q
ec1 98850	499,00	4*

* (Pack indivisible de 4 unidades)
(Indivisible packaging of 4 units)
(Pack indivisible de 4 unités)

Más información Pág. 242
More information / Plus d'informations

CIRCULAR MANUAL BOX
CONJUNTO DE DUCHA
Shower system
Colonne mitigeur douche



Incluye
Includes
Inclus

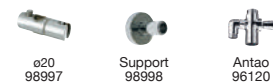
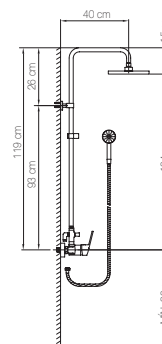

Ref.	€	Q
ec1 99142	289,00	4*

* (Pack indivisible de 4 unidades)
(Indivisible packaging of 4 units)
(Pack indivisible de 4 unités)

Más información Pág. 243
More information / Plus d'informations



99727

START **xtreme**

Conjunto de ducha extensible
Shower system
Colonne mitigeur douche extensible

PANAM EVO urban
CONJUNTO DE DUCHA
Shower system
Colonne mitigeur douche



Incluye
Includes
Inclus



Circular
98518



e20
98997



Syvari 3F
98884





1,75 m
97670

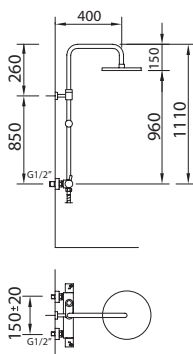

Support
98998

Inversor incorporado en la maneta de caudal
Diverter built in the flow handle
Inverseur intégré dans la poignée



Ref.	€	
ec3  60517	320,00	-

Más información Pág. 116
More information / Plus d'informations



Cisternas empotradas
 Concealed cisterns
 Réservoirs encastrés
 294



Mecanismos descarga
 Flush valves
 Mécanismes chasse d'eau
 295



Sifones
 Bottle trap
 Siphons
 296



Válvulas escuadra
 Angle valves
 Robinets d'équerre
 296



Desagües
 Pop-up wastes
 Vidages
 297

Complementos y recambios

Accesories and spare parts
Accessoires et pièces de rechange



Manetas
Handles
Manettes
298



Cartuchos
Cartridges
Cartouches
300



Inversores
Diverters
Inverseurs
301



Aireadores
Aerators
Aérateurs
302



Accesorios de cocina
Kitchen accessories
Accessoires de cuisine
304



Recambios
Spare parts
Pièces de rechange
305

Cisternas empotradas Concealed cisterns Réservoirs encastrés

ANADYR

Cisterna empotrada para WC al suelo.
Placa doble pulsador incluida
Concealed cistern for wall-hung WC installation.
Dual push plate included.
Réservoir encastré pour wc suspendu ou au sol.
Plaque double poussoir.



Ref.	€	
98324	160,00	1

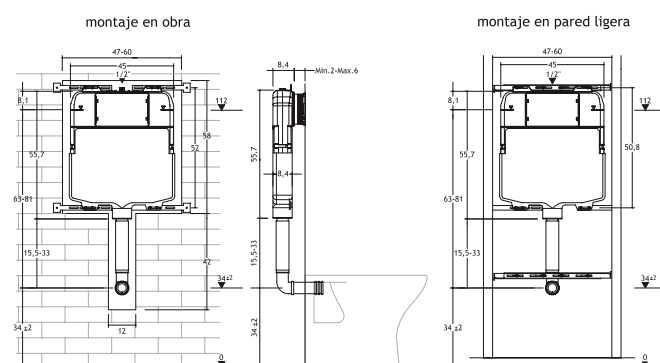
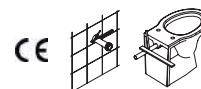

KOLYMA

Cisterna empotrada con bastidor para WC suspendido al suelo.
Placa doble pulsador incluida
Concealed cistern with frame for floor-standing WC. Dual push plate included.
Réservoir encastré avec bâti pour wc au sol.
Plaque double poussoir.



Ref.	€	
98325	342,00	1

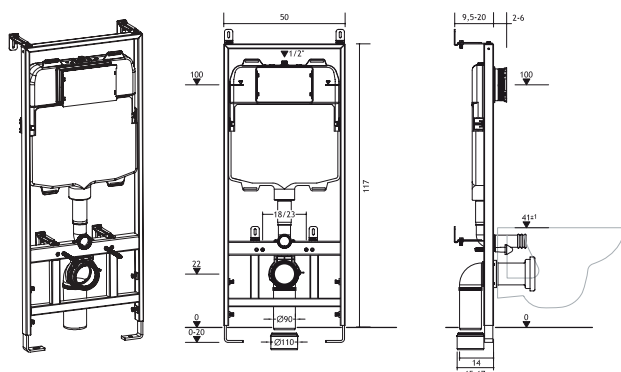
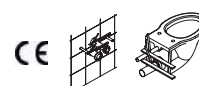

BERING

Placa doble pulsador cromo.
Chromed plated dual push.
Plaque commande double chromée.

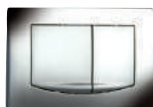

Ref.	€	
98326	40,00	32

Mecanismos descargas

Flush valves
Mécanismes chasse d'eau

OBI

Válvula alimentación inferior. Silencioso, rápido y compacto.
Bottom fill valve. Silent, quick and compact.
Arrivée d'eau inférieure. Silencieux, rapide et compact.

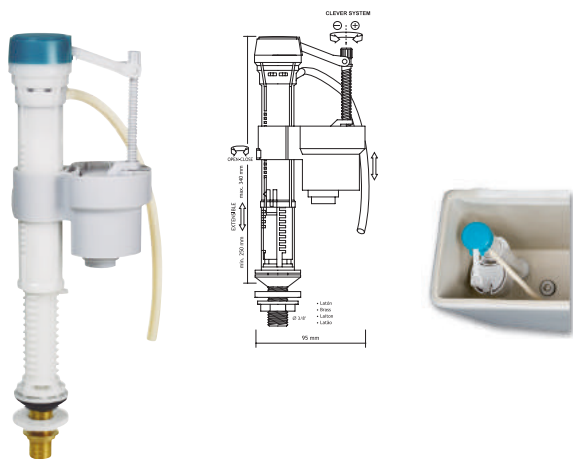

Ref.	€	📦
98320	20,00	4



LENA

Válvula alimentación lateral. Silencioso, rápido y compacto.
Side fill valve. Silent, quick and compact.
Arrivée d'eau latérale. Silencieux, rapide et compact.

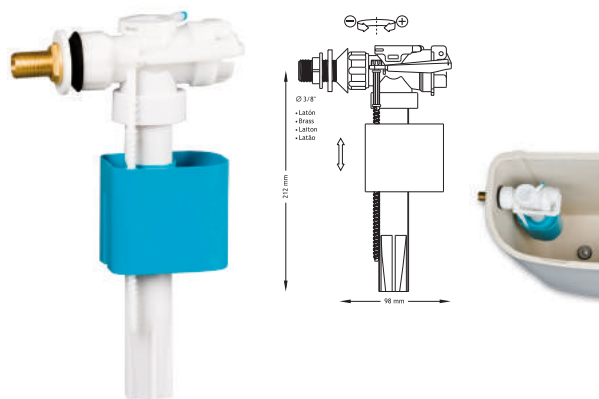

Ref.	€	📦
98321	20,00	4



VOLGA

Descarga eco-control interrumpible. Fácil montaje.
Volumen total interrumpible (opcional).
Water saver press & stop flushing valve. Easy assembly.
Interruptable flush (optional).
Possibilité d'interruption du vidage du réservoir

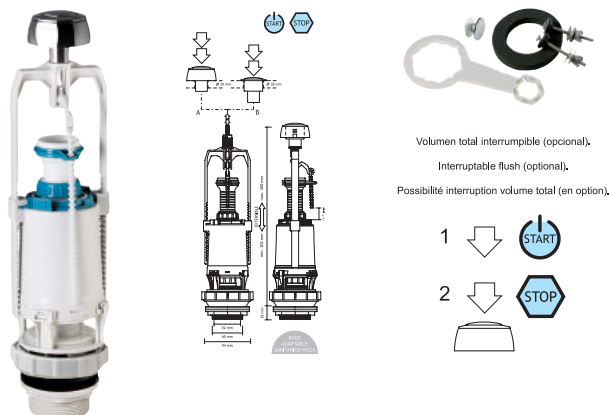

Ref.	€	📦
98322	33,00	4



AMUR

Descarga eco-control con cable.
Water saver cable flushing valve.
Décharge éco-contrôle à câble.

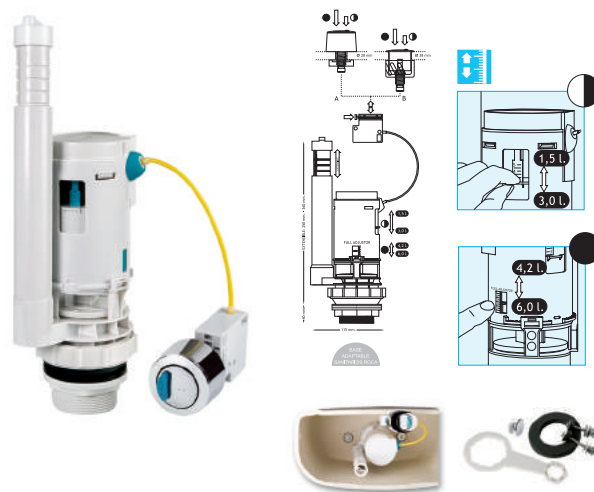

Ref.	€	📦
98323	41,00	4



Sifones

Siphons / Siphons

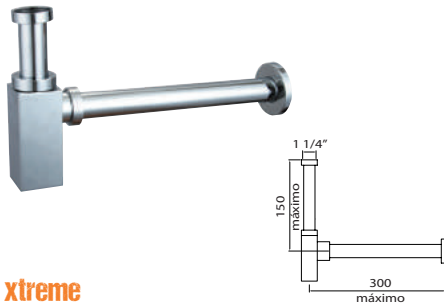

xtreme

SIFÓN BOTELLA LATÓN Brass bottle trap | Siphon laiton

Sifón botella de 1 1/4" de lujo para lavabos de encimera, longitud de tubo lateral hasta 300 mm, longitud del tubo vertical 150 mm, tubo de 32 mm Ø. Luxury square bottle trap 1 1/4" for basin, lateral tube 300 mm long, vertical tube length, 150 mm. Tube 32 mm Ø.
Siphon 1 1/4" de luxe pour vasques à encastrer, longueur de tube latéral 300 mm, longueur de tube vertical 150 mm, tube de 32 mm Ø.

Ref.	€	📦
96173	52,00	10

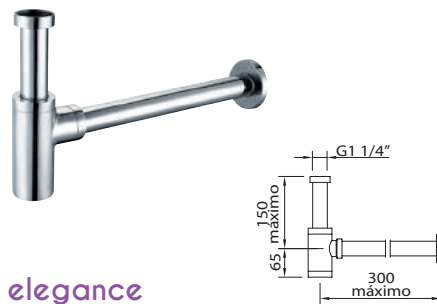

elegance

SIFÓN BOTELLA LATÓN Brass bottle trap | Siphon laiton

Sifón botella de 1 1/4" de lujo para lavabos de encimera, longitud de tubo lateral hasta 300 mm, longitud del tubo vertical 150 mm, tubo de 32 mm Ø. Luxury square bottle trap 1 1/4" for basin, lateral tube 300 mm long, vertical tube length, 150 mm. Tube 32 mm Ø.
Siphon 1 1/4" de luxe pour vasques à encastrer, longueur de tube latéral 300 mm, longueur de tube vertical 150 mm, tube de 32 mm Ø.

Ref.	€	📦
96174	43,00	10

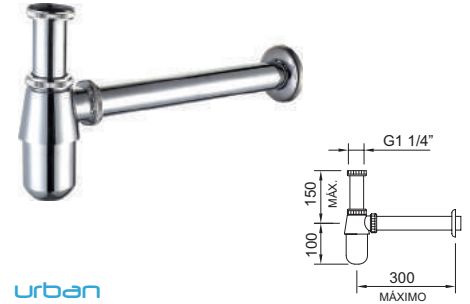

urban

SIFÓN BOTELLA LATÓN Brass bottle trap | Siphon laiton

Sifón horizontal de botella de 1 1/4" para lavabos de encimera, longitud de tubo horizontal 300 mm, longitud de tubo vertical 150 mm, tubo de 32 mm Ø. Bottle bottle trap 1 1/4" for basin, lateral tube 300 mm long, vertical tube length, 150 mm. Tube 32 mm Ø.
Siphon bouteille de 1 1/4" pour vasques à encastrer, longueur de tube horizontal 300 mm, longueur de tube vertical 150 mm. Tube 32 mm Ø.

Ref.	€	📦
90755	23,00	10

Válvulas escuadra

Angle valves / Robinets d'equerre



LATÓN
Brass/Laiton
CW617

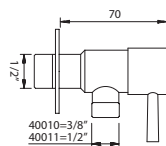

DESIGN

VÁLVULA ESCUADRA Angle valve | Robinet d'equerre

Latón cromado. Cierre discos cerámicos.
Brass chrome. Ceramic disc.
Laiton chromé.
Tête céramique 1/4 de tour

	Ref.	€	📦
1/2" x 3/8"	40010	13,00	100
1/2" x 1/2"	40011	13,00	100



LATÓN
Brass/Laiton
CW617

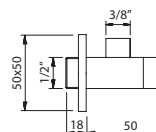

BIMINI

VÁLVULA ESCUADRA Angle valve | Robinet d'equerre

1/2" x 3/8"

Latón cromado. Cierre discos cerámicos.
Brass chrome. Ceramic disc.
Laiton chromé.
Tête céramique 1/4 de tour

Ref.	€	📦
97106	17,00	60

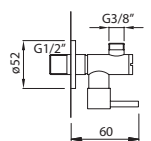

MINAMI

VÁLVULA ESCUADRA CON FILTRO Angle valve with filter Robinet d'equerre avec filtre

1/2" x 3/8"

Latón cromado. Cierre discos cerámicos.
Brass chrome. Ceramic disc.
Laiton chromé.
Tête céramique 1/4 de tour

Ref.	€	📦
97107	17,00	90



Desagües Pop-up / Vidages

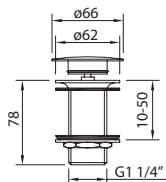

VELA

VÁLVULA DESAGÜE SISTEMA QUICK-CLAC Basin click waste | Vidage quick-clac

Sin rebosadero. Metálico.
Without overflow. Metallic
Pour vasque à poser sans trop plein. Métallique

Con rebosadero. Metálico.
With overflow. Metallic
Pour lavabo et bidet avec trop-plein. Métallique

Ref.	€	📦
97395	18,00	50
96255	18,00	50

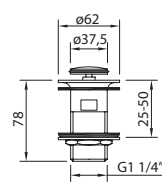

ORION

VÁLVULA DESAGÜE SISTEMA QUICK-CLAC Basin click waste | Vidage quick-clac

Con rebosadero. Metálico.
With overflow. Metallic
Pour vasque à poser avec trop plein. Métallique

Ref.	€	📦
96254	18,00	50

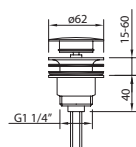

Metálico
Metallic · Métallique



LEO BLANCO MATE

VÁLVULA DESAGÜE SISTEMA QUICK-CLAC Basin click waste | Vidage quick-clac

Válvula desagüe Universal. Metálico.
Universal drain quick-clac. Metallic
Vidage Universel. Métallique

Acabado en blanco.
White finish.
Finition blanc.

Ref.	€	📦
60701	16,00	-

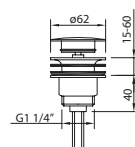

Metálico
Metallic · Métallique



LEO NEGRO MATE

VÁLVULA DESAGÜE SISTEMA QUICK-CLAC Basin click waste | Vidage quick-clac

Válvula desagüe Universal. Metálico.
Universal drain quick-clac. Metallic
Vidage Universel. Métallique

Acabado en negro.
Black finish.
Finition noir.

Ref.	€	📦
60702	16,00	-

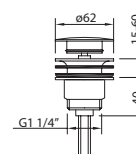

Sintético
Synthetic · Synthétique

LEO

VÁLVULA DESAGÜE SISTEMA QUICK-CLAC Basin click waste | Vidage quick-clac

Válvula desagüe Universal. Sintético. 1 1/4"
Universal drain quick-clac. Synthetic 1 1/4"
Vidage Universel. Synthétique. 1 1/4"

Ref.	€	📦
60558	12,00	50

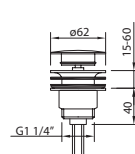

Metálico
Metallic · Métallique

LEO

VÁLVULA DESAGÜE SISTEMA QUICK-CLAC Basin click waste | Vidage quick-clac

Válvula desagüe Universal. Metálico.
Universal drain quick-clac. Metallic
Vidage Universel. Métallique

Ref.	€	📦
98674	15,00	1
60418	14,00	24

Box (Pack 24)

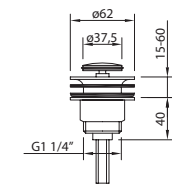

LYNX

VÁLVULA DESAGÜE SISTEMA QUICK-CLAC Basin click waste | Vidage quick-clac

Válvula desagüe Universal. Metálico.
Universal drain quick-clac. Metallic
Vidage Universel. Métallique

Ref.	€	📦
98673	14,00	50

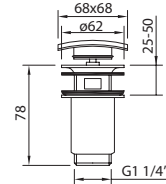

HYDRA

VÁLVULA DESAGÜE SISTEMA QUICK-CLAC Basin click waste | Vidage quick-clac laiton

Válvula desagüe Universal. Metálico.
Universal drain quick-clac. Metallic
Vidage Universel. Métallique

Ref.	€	📦
98675	18,00	50

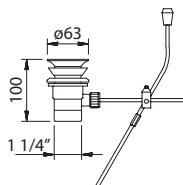

METÁLICO - Desagüe automático
Metallic - Pop-up waste
Métallique - Vidage laiton

Desagüe automático de 1 1/4" con tirador para lavabo y bidé.

Pop-up 1 1/4" for basin and bidet.

Vidage automatique 1 1/4" pour lavabo/bidet.

Ref.	€	📦
NF 99127	15,00	50

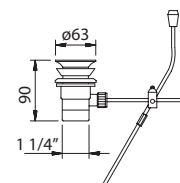

SINTÉTICO - Desagüe automático
Synthetic - Pop-up waste
Synthétique - Vidage laiton

Desagüe automático de 1 1/4" con tirador para lavabo y bidé.

Pop-up 1 1/4" for basin and bidet.

Vidage automatique 1 1/4" pour lavabo/bidet.

Ref.	€	📦
92901	5,50	50
NF 99130	8,50	50

Manetas

Handles/ Manettes

Clever Platinum

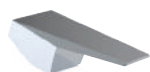

Ref.	Serie	€	Standard	Invertida Inverted
99426	VENTU	21,00	○	
99427	VENTU	21,00		○
95163	AUDE	21,00	○	
95164	AUDE	21,00		○
95168	SELENE	21,00	○	
95169	SELENE	21,00		○
95165	BIMINI Ø35	21,00		○
95167	BIMINI bimando	21,00	○	
95178	BIMINI Ø40	21,00	○	
99424	MARINA EVO	21,00	○	
99425	MARINA EVO	21,00		○
95244	SAONA SLIM Ø26	21,00	○	
95245	SAONA SLIM Ø35	21,00	○	
95246	SAONA SLIM Ø26	21,00		○
98215	PAULA	21,00	○	
98216	PAULA	21,00		○

Clever Styles



Ref.	Serie	€	Standard	Invertida Inverted	C3	C3 Invertida Inverted
95183	AGORA ELEGANCE	13,00	○			
95184	AGORA ELEGANCE	13,00		○		
95242	AGORA XTREME	13,00	○			
95243	AGORA XTREME	13,00				○
60708	AGORA XTREME	13,00	○			
60709	AGORA XTREME	13,00	○			
95185	ARTIC XTREME	13,00	○			
95186	ARTIC XTREME	13,00				○
95187	ARTIC XTREME	13,00			○	
98240	ARTIC URBAN	13,00	○			
98241	ARTIC URBAN	13,00		○		
95133	CAIMAN ELEGANCE Ø40	21,00	○			
95132	CAIMAN ELEGANCE Ø35	21,00	○			
98212	CAIMAN XTREME	13,00	○			
98213	CAIMAN XTREME	13,00		○		
98242	CAIMAN XTREME baño-ducha	13,00	○			
96223	CAIMAN URBAN	13,00	○			
94600	WITH2 ANTIGONA	12,00				
95126	WITH2 MOREA	21,00				

Chef/Inox/Osmosis



Ref.	Serie	€	Standard	Invertida Inverted	C3 Invertida Inverted
95158	CHEF	21,00		○	
60733	CHEF ø35 3 vías	21,00		○	
98758	CHEF CARBON	21,00		○	
99446	CHEF 35	21,00		○	
99447	CHEF 35	21,00			○
99659	CHEF 35 MATE	21,00			○
95247	CHEF 25	21,00			○
99852	INOX FINISH	21,00		○	
95248	OSMOSIS ROUND 35	21,00			○
95250	OSMOSIS ROUND	13,00	○		

Ref.	Serie	€	Standard	Invertida Inverted	C3 Invertida Inverted
95249	OSMOSIS SQUARE 35	21,00			○
95251	OSMOSIS SQUARE	13,00	○		
98631	OSMOSIS (Para 97806-99684)	13,00	○		
98632	OSMOSIS (Para 96419-98760)	13,00	○		
60315	CHEF 6 BLANCA	21,00			○
60316	CHEF 25 SLIM MATE	21,00			○
60317	CHEF 25 SLIM BLANCA	21,00			○
60318	CHEF 25 SLIM NEGRA	21,00			○

Clever Styles Pro



Ref.	Serie	€	Standard	Invertida Inverted	C3	C3 Invertida Inverted
98209	BAHAMA XTREME	13,00	○			
98210	BAHAMA XTREME	13,00		○		
95190	BAHAMA XTREME	13,00			○	
95191	BAHAMA XTREME	13,00				○
98206	HABANA XTREME	13,00	○			
95192	HABANA XTREME	13,00			○	
95234	START ELEGANCE	13,00	○			
95235	START ELEGANCE	13,00		○		
95236	START ELEGANCE	13,00			○	
95237	START ELEGANCE	13,00				○
60714	START ELEGANCE	13,00	○			
60715	START ELEGANCE	13,00	○			
95226	START XTREME	13,00	○			
95227	START XTREME	13,00		○		
95228	START XTREME	13,00			○	
95229	START XTREME	13,00				○
95181	START URBAN	13,00	○			
95182	START URBAN	13,00		○		
95193	START URBAN	13,00			○	
95194	START URBAN	13,00				○
95012	PANAM URBAN	9,50	○			
95110	PANAM URBAN	9,50		○		
95230	S12 ELEGANCE	9,50	○			
95231	S12 ELEGANCE	9,50		○		
95232	S12 ELEGANCE	9,50			○	
95233	S12 ELEGANCE	9,50				○
95222	S12 XTREME	9,50	○			
95223	S12 XTREME	9,50		○		
95224	S12 XTREME	9,50			○	
95225	S12 XTREME	9,50				○
95174	S12 URBAN 40	9,50	○			
95175	S12 URBAN 40	9,50		○		
95195	S12 URBAN 40	9,50			○	
95196	S12 URBAN 40	9,50				○
99224	S12 URBAN 35	9,50	○			
99225	S12 URBAN 35	9,50			○	

Ref.	Serie	€
96232	WITH2 GUAYAMA Fría/Cold/Froid	7,50
96233	WITH2 GUAYAMA Caliente/Hot/Chaud	7,50

97822	SHATAFF Monomando/ Single lever	9,50
97823	SHATAFF Bimando/ Two handle	9,50
96234	INDIVIDUAL - Single	3,75
96256	MEDICA - Medical	15,00
99217	S12 URBAN Medica	15,00

Standard



Invertida
Inverted



C3
Standard



C3
Invertida
Inverted



Cartuchos Cartridges/ Cartouches



INVERSOR | *Diverter* | *Poignée*

Inversor automático baño-ducha.
Bath-shower automatic diverter.
Inverseur automatique bain-douche.

	Ref.	€
 Hide diverter	97817	19,00
Selene	98008	19,00
Ventu	99664	19,00
Bimini	97474	19,00
Saona Slim	60129	19,00
Agora Xtreme	60114	19,00
Nine	98239	19,00

	Ref.	€
Antao	96217	16,00
Caiman Urban	96213	16,00
Bahama urban	90770	11,00
Panam Urb.-S12 urban-Panam X. 	98490	11,00
Bimini empotrado	98491	16,00
Guayama - Madeira	95052	9,50
Para barra Bimini	60310	19,00

CARTUCHOS | *Cartridges* | *Cartouche*

							
Standard salida libre 	ø35	96199		97371	99667	99665	98868
	ø40	90760		97369	99668	99669	98866
Standard salida conductida 	ø25	97824					
	ø35	96205		97372			98869
		90763*					
	ø35 NF	99226	99227		99228	99656	
ø40	90761		97370	99670	99671	98867	
Tórica superior salida libre 	ø35	98238	98267		98872	99672	99673
Tórica superior Xtreme 	ø26	60130					
	ø35 NF	99540	99541		99542	99543	99674
		99817					
	ø40 NF	98870	98781		98902	98903	98871
ø40	98237	98630					

* Joystick

	Ref.	€
ec1	90760	10,00
ec1	90761	10,00
	90763	21,00
ec1	96199	10,00
ec1	96205	10,00
ec2	97369	14,00
ec2	97370	14,00
ec2	97371	14,00
ec2	97372	14,00
ec1	97824	17,00
ec1	98237	10,00
ec1	98238	10,00
ec2	98267	14,00
ec2	98630	14,00
C2	98781	16,00
ec3	98866	14,00
ec3	98867	14,00
ec3	98868	14,00
ec3	98869	14,00
C1	98870	13,00
C3	98871	17,00

	Ref.	€
ec3	98872	18,00
C3	98902	17,00
C3	98903	17,00
C1	99226	13,00
C2	99227	16,00
C3	99228	17,00
C1	99540	13,00
C2	99541	16,00
C3	99542	17,00
C3	99543	17,00
ec3	99656	17,00
ec3	99665	19,00
ec3	99667	17,00
ec3	99668	17,00
ec3	99669	17,00
ec3	99670	17,00
ec3	99671	17,00
ec3	99672	17,00
ec3	99673	17,00
C3	99674	17,00
ec1	60130	17,00
ec1	99817	13,00

Instrucciones de montaje de un cartucho, ver página 345

Cartridge assembly instructions. See page 345

Instructions de montage d'une cartouche, voir page 345



CARTUCHO INVERSOR
Diverter cartridge | Cartouche inverseur

OFF. Para, for, pour: Nine Xtreme 60135

NO OFF. Para, for, pour: Start 99646-99747

3 VÍAS. ø35 Para, for, pour: 60731

Ref.	€
60139	17,00
60313	17,00
60732	17,00



CARTUCHO INVERSOR ø27
Diverter cartridge | Cartouche inverseur

OFF. Para, for, pour: Nine Urban

NO OFF. Para, for, pour: 99732-60154

Ref.	€
98776	19,00
60312	17,00

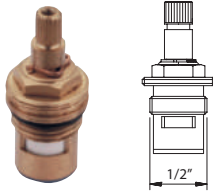

MONTURA CERÁMICA
Ceramic Headwork
Tête céramique

	Ref.	€
Old Antigona	94458	8,50
Guayama - Antigona	96208	8,50
Guayama 92075 y 97974	94459	8,50
Caiman 98760	97697	8,50
Caiman 97806-99684	97698	8,50
Bimini 97054	97699	8,50



CARTUCHO
Cartridge | Cartouche

Cartucho termostático.
Thermostatic cartridge.
Cartouche pour thermostatique.

Para 60131,60133

Para 98750



cosedal

Ref.	€
98027	52,00
99652	57,00
99736	57,00



NINE
CARTUCHO CON VOLANTE
Cartridge with handle | Cartouche

Cartucho termostático con volante ABS cilíndrico.
Thermostatic cartridge with ABS cylindrical handle.
Cartouche céramique pour thermostatique, poignée ABS cylindrique.

Ref.	€
97829	75,00



cosedal



97827



97828

NINE
VOLANTE
Handle | Poignée

ABS

Volante ON/OFF.
ON/OFF handle./Poignée ON/OFF.

Volante termostático.
Thermostatic handle./ Poignée thermostatique.



Ref.	€
97827	5,50
97828	5,50



CARTUCHO
Cartridge | Cartouche

Cartucho temporizado
Delay action cartridge
Cartouche temporisée

	Ref.	€
M26 7 segundos - seconds	96161	20,00
M26 14 segundos - seconds	96164	20,00

	Ref.	€
M28 14 segundos - seconds	60737	21,00
M28 7 segundos - seconds	60738	21,00



cosedal

NEW

NEW



60416



60417

NINE SLIM urban
VOLANTE
Handle | Poignée

ABS

Volante ON/OFF.
ON/OFF handle./Poignée ON/OFF.

Volante termostático.
Thermostatic handle./ Poignée thermostatique.



Ref.	€
60416	5,50
60417	6,50

Aireadores Aerators/ Aérateurs

AIREADOR con mezcla aire/agua variable

Permite que el usuario escoja el grado de mezcla aire/agua que necesita sin limitador de caudal.

AERATOR, MIXING AIR AND WATER. Allows the user to choose the necessary mixing level air/water without using a flow limiter.

AÉRATEUR, AVEC MÉLANGE AIR/EAU VARIABLE. Permet à l'utilisateur de choisir la proportion de mélange air/eau dont il a besoin sans limiteur de débit.

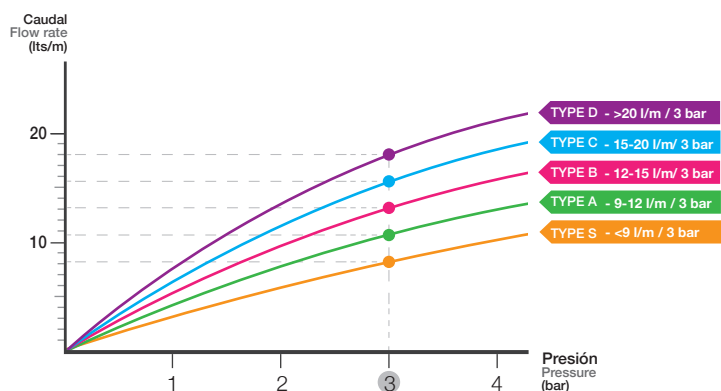

NEW Nuevo formato blister*
New blister format
Nouveau format de blister

NEOPERL
TYPE A

Ref.	€	
60686*	5,50	Macho/Male
60687*	5,50	Hembra/Female

		TYPE S <9 l/m - 3 bar	TYPE A 9-12 l/m - 3 bar	TYPE B 12-15 l/m - 3 bar	TYPE C 15-20 l/m - 3 bar	TYPE D >20 l/m - 3 bar
Male 	M20	96202	97689			
	M24	99230	60686*	90025	99231	96200
	M24 filtro silicona			98926		
	M28				99233	90027
Female 	M20			98601		
	M22	99853 Inox	60687*	90026		
	M22 filtro silicona			98927		
Rectangular 	28x7		99661			
	32x8		98492			
	40x10		99660		98493	
Slim-orientable 	M24			98774		98775
Empotrado 	M18	60149				
	M16	60710				
CoinSlot 	M24		60155			
Osmosis 	M22			60153		
	M24			99737		

Ref.	€	Ref.	€	Ref.	€	Ref.	€	Ref.	€	Ref.	€	Ref.	€
96202	5,00	99661	23,00	90025	6,00	90026	6,00	99231	6,00	96200	6,00	99853	7,00
99230	6,00	98492	28,00	98926	7,00	98927	7,00	99233	6,00	90027	6,00	60149	11,00
97689	5,00	99660	28,00	98601	5,00	98774	6,00	98493	32,00	98775	9,50	60155	16,00
												60153	16,00
												99737	16,00
												60710	11,00



AIREADOR con límite de caudal máximo

Permite limitar el caudal máximo, independientemente de la posición de la maneta, consiguiendo así un mayor ahorro de agua. (No recomendable para grifería de bañera).





AERATOR, WITH MAXIMUM FLOW LIMIT.

To limit the maximum flow rate regardless the handle position, saving more water. (it is not recommended for bath mixers)

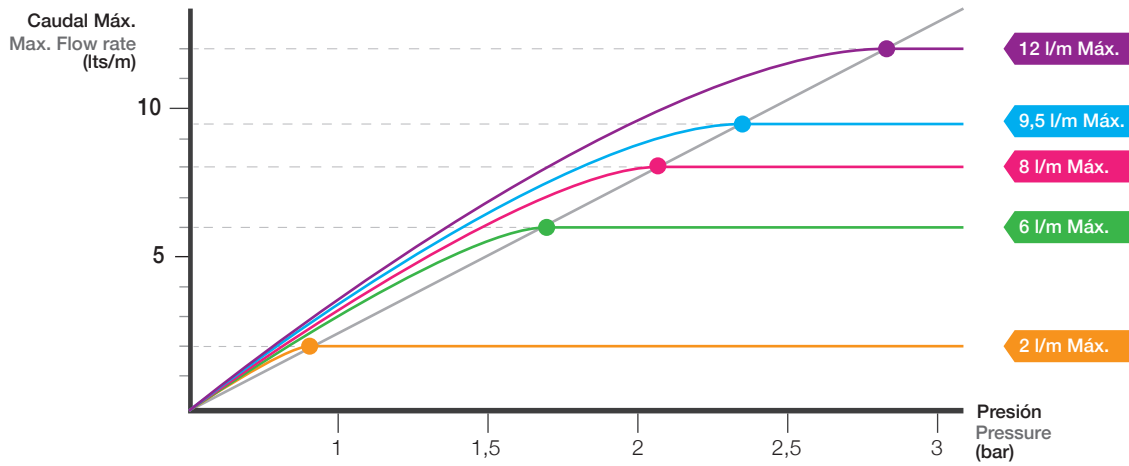
AÉRATEUR, AVEC LIMITE DE DÉBIT MAXIMUM

Permet de limiter le débit maximum indépendamment de la position de la manette, obtenant ainsi une économie d'eau supplémentaire (non recommandé pour la robinetterie de baignoire).



		2 l/m Máx.	6 l/m Máx.	8 l/m Máx.	9,5 l/m Máx.	12 l/m Máx.
Male 	M24	98788	98787	98793		
Female 	M22	98794	98789	98795		
Slim-orientable 	M24		98791	98792		
Ducha Baño 	1/2"		98796		98786	98797

Ref.	€	Ref.	€
98788	6,50	98793	4,75
98794	4,75	98795	4,75
98787	5,00	98792	6,50
98789	6,50	98786	2,50
98791	6,50	98797	2,50
98796	2,50		



RÓTULA BIDÉ
Ball-joint aerator | Rotule bidet

Rótula bidé. M24 - M22
Knee- cap. M24 - M22.
Rotule bidet. M24 -M22.

Ref.	€
96201	7,00

Accesorios cocina

Kitchen accessoires
Accessoires de cuisine

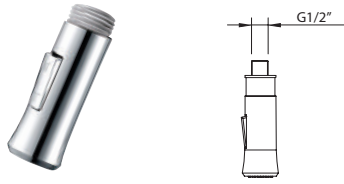

DUCHA DE PISTOLA
Dishwashing pull-out | Douchette

98759: para, for, pour: 98757 - 98764 - 99440
99441 - 99443 - 99444 - 60142 - 60729
99658: para, for, pour: 99445 (Mate)

ABS



Ref.	€	📦
98759	31,00	50
99658	31,00	50



DUCHA DE PISTOLA
Dishwashing pull-out | Douchette

60314: Para, for, pour: 99733-99735
99657: Para, for, pour: 99442

ABS



Ref.	€	📦
60314	31,00	-
99657	31,00	50

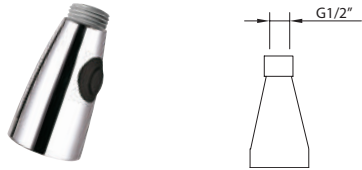

DUCHA DE PISTOLA
Dishwashing pull-out | Douchette

Para, for, pour: 96755 - 97804

ABS



Ref.	€	📦
97364	31,00	50



DUCHA DE PISTOLA
Dishwashing pull-out | Douchette

Para, for, pour: 98689

ABS



Ref.	€	📦
99174	31,00	-

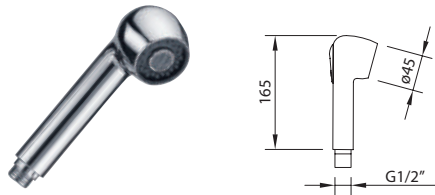

DUCHA
Pull-out handshower for sink mixer | Douchette

Para fregadero 97069 - 98552 - 98180
Pull-out handshower for sink mixer
97069 - 98552 - 98180
Pour évier 97069 - 98552 - 98180

ABS



Ref.	€	📦
90794	18,00	50

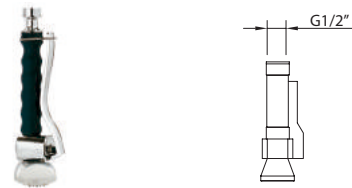

DUCHA DE PISTOLA
Dishwashing pull-out | Douchette

Para, for, pour: 96175 - 96176

Metálico / Metallic / Métallique



Ref.	€	📦
96273	93,00	50



Recambios Spare parts Pièces de rechange

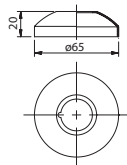

FLORONES Flange | Rosace

Metálico cromado (2 piezas)
Chromed metal (2 pieces)
Métal chromé (2 pièces)

Ref.	€	📦
95043	4,00	10

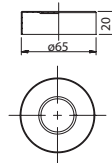

FLORONES Flange | Rosace

Florón lomo plano (2 piezas). Cromado
Flange (2 pieces). Chromed
Rosace (2 pièces). Chromé

Ref.	€	📦
96238	6,00	10

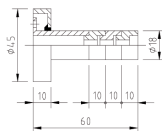

SOPORTE PARED Wall support | Support mural

Soporte pared para conjuntos de ducha.
Wall support for shower set.
Support mural.

Ref.	€	📦
ø 25 98497	16,00	10
ø20 98998	13,00	10

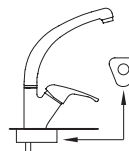

REFUERZO FREGADEROS Reinforcement sink | Renfort robinet évier

Universal
ø35

ABS



Ref.	€	📦
97688	2,25	90

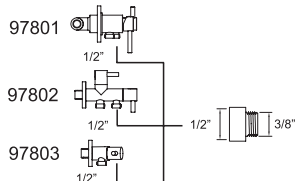

SHATTAF REDUCTOR Reducer connection | Réducteur de connexion

Latón cromado
Brass chromed
Laiton chromé

1/2"H x 3/8"M

1/2"F x 3/8"M

Ref.	€	📦
97825	3,75	20

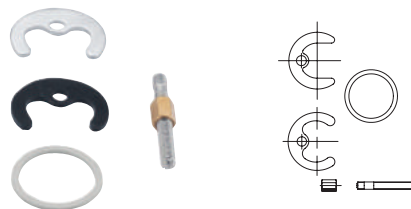

CONJUNTO DE FIJACIÓN Fixing set | Set de fixation

Conjunto de fijación para lavabo, bidé y fregadero.
Fixing set rim mounted faucets (basin, bidet, sink).
Set de fixation (lavabo, bidet, évier).

96267: Largo - Long / 110mm
95040: Universal

Ref.	€	📦
96267	6,50	20
95040	2,75	20

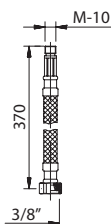

FLEXIBLE DE ALIMENTACIÓN Flexible connections | Raccords flexibles

99862/98666: M-10 x 370 mm x 3/8"
DN6
EPDM.



98667: M-10 x 370 mm x 3/8"
DN6
PEX

98986: M-10 x 420 mm x 3/8"
DN6
EPDM

96243: M-10 x 370 mm x 3/8"
DN8
EPDM

Ref.	€	📦
98666	2,75	250
99862	2,75	250
98667	2,75	250
98986	2,75	250
96243	2,75	250



Recambios Spare parts Pièces de rechange



INDICES Indice | Index

ABS

	Ref.	€	📦
Antigona F	95044	2,25	10
Antigona C	95045	2,25	10
Antigona H	95046	2,25	10
	Ref.	€	📦
Universal	97363	1,25	10



ADAPTADOR Adapter | Adaptateur

Adaptador para tubo PE 1/4" - 7/16"-24 H (para 97104, 97806, 98760, 60150, 60151, 99684).
Adapter for PE 1/4" - 7/16"-24 F pipe (for 97104, 97806, 98760, 60150, 60151, 99684).
Adaptateur tubo PE 1/4" - 7/16"-24 H (pour 97104, 97806, 98760, 60150, 60151, 99684).



	Ref.	€	📦
	97399	7,00	10

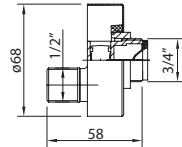

3/4"x1/2" (2 unidades, 2 units, 2 unités)
Conjunto Excéntrica con válvula
On/Off + filtro + florón
Eccentric nut On/Off valve +
filter + flange
Vanne excentrique On/Off +
filtre + rosace

	Ref.	€	📦
	98647	39,00	2

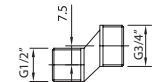

3/4"x1/2" (2 unidades, 2 units, 2 unités)
Excéntricas
Eccentric nut- Excentré

95042: Universal
96299: Con disminución ruido
With noise reduction / Avec silencieux



	Ref.	€	📦
	95042	7,50	25
	96299	9,50	10

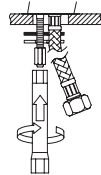

HERRAMIENTA DESMONTAJE
CONJUNTO FIJACIÓN
Dismantling tool for fixation set
Outil de démontage ensemble de fixation

Hexagonal 11

	Ref.	€	📦
	98751	3,75	1



HERRAMIENTA DESMONTAJE AIREADOR
Dismantling tool for aerator
Outil de démontage aérateur

Universal M-28-M24-M22

	Ref.	€	📦
	98752	3,75	1



ANTIGONA

INVERSOR
Diverter | Inverseur

Inversor manual baño-ducha.
Diverter for bath-shower.
Inverseur manual.

	Ref.	€	📦
	95051	13,00	20

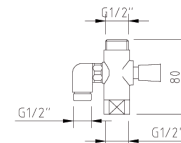

ANTAO

INVERSOR
Diverter | Inverseur

Distribuidor Antao para tubo de conjunto de ducha.
Diverter for shower set with tube.
Inverseur Antao.

	Ref.	€	📦
	96120	40,00	20

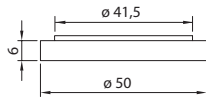

BASE PLÁSTICA S12 / START
Plastic base | Base en plastique

ABS
Ø50

Ref.	€	
60559	1,90	-

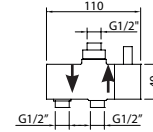

KIT BOX

INVERSOR
Diverter | Inverseur

Distribuidor para 99136/99623
Diverter for 99136/99623
Inverseur pour 99136/99623



Ref.	€	
99172	40,00	-

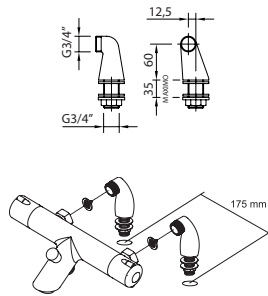

EXTENSIONES
Extensions | Extensions

Extensiones 3/4" x 3/4" (2 unidades). No Mikura, no Marina.
Extensions 3/4" x 3/4" (2 units). Not Mikura, not Marina.
Colonnettes excentrées 3/4" x 3/4" (2 unités)

Ref.	€	
96292	43,00	10

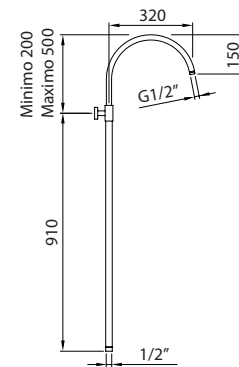

CROSS Ø25

EXTENSIBLES
Adjustable | Extensible

Tubo extensible recto para conjuntos ducha.
Latón cromado
Adjustable tube for shower set. Brass chromed
Barre extensible. Laiton chromé

Ref.	€	
96118	191,00	4

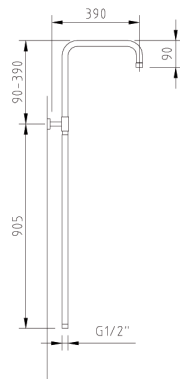

CIRCULAR Ø25

EXTENSIBLES
Adjustable | Extensible

Tubo extensible recto para conjuntos ducha.
Latón cromado
Adjustable tube for shower set. Brass chromed
Barre extensible. Laiton chromé

Ref.	€	
98517	191,00	4

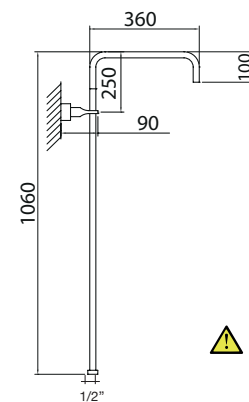

BASIC BOX

Tubo recto para conjuntos ducha.
Acero inox cromado
Tube for shower set. Stainless steel chromed
Barre. Inox chromé

⚠ NO EXTENSIBLE
NOT EXTENDABLE.
NON EXTENSIBLE

Ref.	€	
98996	124,00	20



EXPOSITORES

Expositores Clever, perfectos para tu tienda

Floorstand, perfect for your shop
Présentoir Clever, parfait pour votre comptoir



Expositores sobremesa
Display stand over-table
Présentoirs
310



Clever Maxi
312

Expositores sobremesa Display stand over-table Présentoirs

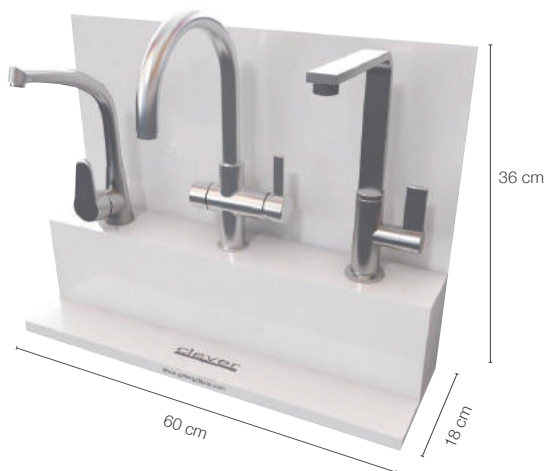

CLEVER KITCHEN

EXPOSITOR SOBREMESA DE COCINA Kitchen faucet display stand over-table Présentoir cuisine

Grifería no incluida
Faucets not included
Robinetterie non comprise

Ref.	€	
95821	186,00	1

Posibles configuraciones

Possible configurations / Configurations possibles



Ref.	€		
Expositor Display / Présentoir	95821	186,00	1
Vinilo Vinyl / Vinye	95666	54,00	1

Expositor 1



Ref.	€		
Expositor Display / Présentoir	95821	186,00	1
Vinilo Vinyl / Vinye	95829	54,00	1

Expositor 2

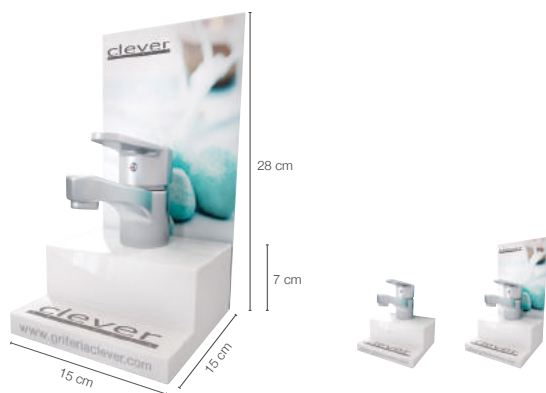

CLEVER ONE

EXPOSITOR SOBREMESA CON CARTELA IMANTADA Faucet display stand over-table with billboard magnetised Présentoir robinetterie avec panneau aimanté

Grifería no incluida
Faucets not included
Robinetterie non comprise

Posible configuración, con o sin cartela

Possible configurations, with or without billboard
Configurations possibles avec/sans panneau

Ref.	€	
95717	33,00	1

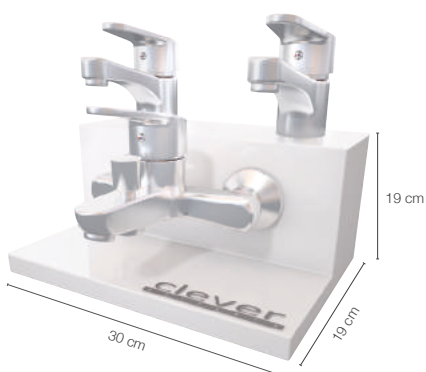

CLEVER MINI

EXPOSITOR SOBREMESA Faucet display stand over-table Présentoir robinetterie

Grifería no incluida
Faucets not included
Robinetterie non comprise

Incluye vinilo imantado APP Clever.
Magnetized vinyl APP Clever included.
Vinye aimante APP Clever compris.



(9x9cm)

Ref.	€	
95540	97,00	1

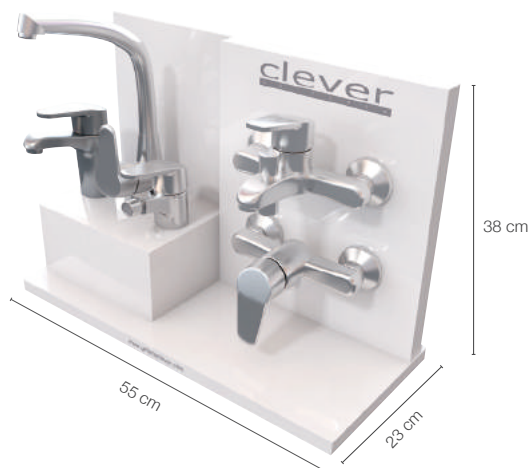

CLEVER FIVE
EXPOSITOR SOBREMESA
Faucet display stand over-table
Présentoir robinetterie

Grifería no incluida
 Faucets not included
 Robinetterie non comprise

Ref.	€	
95753	181,00	1

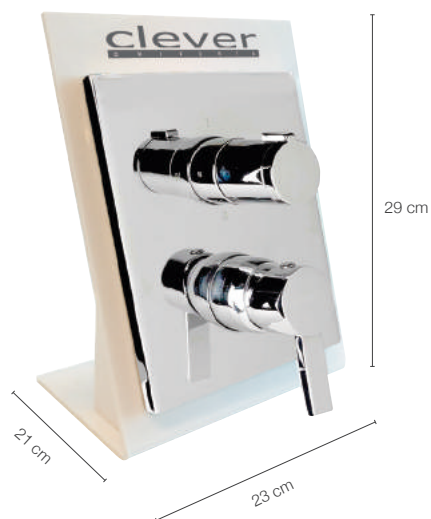

iCLEVER
EXPOSITOR iCLEVER SOBREMESA
iclever display stand over-table
Présentoir iclever

Grifería no incluida
 Faucets not included
 Robinetterie non comprise

Ref.	€	
95754	67,00	1



CLEVER SHATTAF
EXPOSITOR DUCHA HIGIÉNICA SOBREMESA
Shattaf display stand over-table
Présentoir douche hygiénique

Grifería no incluida
 Faucets not included
 Robinetterie non comprise

Ref.	€	
95755	78,00	1

Expositor Clever Maxi

Clever maxi display
Présentoir Clever maxi

CLEVER MAXI. Personalízalo a tu manera.

Clever maxi. Customize it as you want / Clever maxi. Personnalisez-les à votre goût



95667
Expositor modular metálico
Metal faucet display stand
Présentoir métallique



95749
Soporte repisa
para fregadero extraíble
Pull-out sink mixersupport
Support pour évier avec
douchette extractible



95668
Soporte repisa
para lavabo, bidé o fregadero
Support for basin, bidet or sink
Support pour lavabo, bidet ou évier



95756
Soporte doble repisa
para lavabo, bidé o fregadero
Double support for basin, bidet or sink
Double support pour lavabo, bidet ou évier



95669
Soporte baño-ducha o ducha
Support for bath-shower or shower
Support pour bain-douche ou douche



95663
Pieza blanca
White piece
Pièce blanche



95670
Soporte de madera
para duchas teléfono
Wood Holder for handshower
Support en bois pour douchettes



95824
Soporte repisa
para duchas teléfono
Support for handshower
Support pour douchettes



95832
Soporte doble
para Nine Elegance
y Nine Xtreme
 Double support for Nine Elegance and
 Nine Xtreme
 Double support pour Nine Elegance
 et Nine Xtreme



95828
Soporte doble de madera
 Double wood Holder
 Double support en bois



95839
Soporte con un gancho
 Support with one hook
 Support avec un crochet



95840
Soporte con dos ganchos
 Support with two hooks
 Support avec deux crochets



95837
Bandeja simple
 Simple tray
 Plateau simple

30 x 30 x 27 cm



95838
Bandeja doble
 Double tray
 Double plateau

30 x 60 x 27 cm

Ref.	€	📦
95667	538,00	1
95749	38,00	1
95668	33,00	1
95756	41,00	1
95669	33,00	1
95663	22,00	1
95670	43,00	1

Ref.	€	📦
95824	54,00	1
95832	93,00	1
95828	93,00	1
95839	41,00	1
95840	43,00	1
95837	52,00	1
95838	93,00	1

Expositor Clever Maxi

Clever maxi display
Présentoir Clever maxi

Decora tu Clever Maxi con la cartela trasera o vinilos imantados
Decorate your Clever maxi / Décorer votre Clever maxi



95671
Imagen trasera
(uso recomendado cuando el expositor NO va contra la pared)
Rear image
(recommended use when the display is not placed against the wall)
Image de fond
(utilisation recommandée lorsque le présentoir n'est pas contre le mur)



95664
Vinilo imantado
Imagen ducha
Magnetized vinyl. Shower Image
Vinyle aimanté. Image de douche



95665
Vinilo imantado. Imagen baño
Magnetized vinyl. Mixer Image
Vinyle aimanté. Image de bain



95666
Vinilo imantado. Imagen cocina
Magnetized vinyl. Sink Image
Vinyle aimanté. Image de Cuisine



95829
Vinilo imantado. Imagen azulejos cocina
Magnetized vinyl. Tiles image
Vinyle aimanté. Image de tuiles



95806
Vinilo imantado Hidroclever
Magnetized vinyl. Hidroclever image
Vinyle aimanté. Image de hidroclever

Ref.	€	
95671	72,00	1
95664	57,00	1
95665	54,00	1
95666	54,00	1
95829	54,00	1
95806	54,00	1

Fáciles de montar

Easy to assemble / Facile à assembler



Expositor Clever Maxi

Clever maxi display
Présentoir Clever maxi

CLEVER MAXI. Posibles configuraciones.

Clever maxi. Possible configurations / Clever maxi. Configurations possibles

Expositor 1



Expositor 2



Expositor 3



Expositor 4



Expositor 5



Expositor 6



Expositor 7



Expositor 8



Expositor 9



Expositor 10



Expositor 11



Expositor 12



	Incluye																		
	95667	95668	95669	95670	95663	95749	95756	95632	95828	95824	95839	95840	95637	95638	95664	95665	95666	95829	95806
Expositor 1	1	8																	
Expositor 2	1	4	4																
Expositor 3	1		2	2	4														
Expositor 4	1	1	3	1	2		1												
Expositor 5	1	2	2		4											1		1	
Expositor 6	1	1	1		4	2											1	1	
Expositor 7	1				4			1	1										
Expositor 8	1				4			1	1										1
Expositor 9	1		1				2			1	1	2	1						
Expositor 10	1	1	1							1	1	1		1					
Expositor 11	1		2	2	4														
Expositor 12	1	2	2	4															



Mikura
320



Saona
321



Marina
322



Artic **urban**
323



Caiman **elegance**
323



Caiman **urban**
323



With2 **morea**
324

Off Clever

Hasta finalizar existencias

While stocks last / Jusqu'à épuisement du stock



Bahama **urban**
325



Panam **elegance**
326



Panam **xtreme**
328



Nine **urban**
330



Temporizados
Delay action
Temporisés
330



Chef
331

Off Clever

Mikura

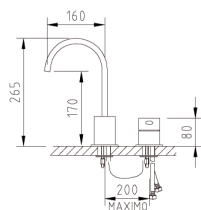

LAVABO REPISA 170

Two hole deck Basin 170 | Mitigeur lavabo 2 trous 170

Mezclador con rompeaguas, caño giratorio.
Two hole deck basin with water breaker, swivel spout.
Mitigeur lavabo, brise-jet, bec orientable

Ref.	€	
97411	194,00	4



95154 97372 97381

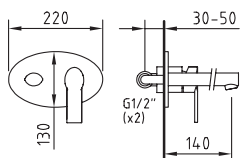

LAVABO MURAL EMPOTRAR

Concealed wall mounted basin | Lavabo à encastrer

Mezclador empotrable mural, caño con aireador, longitud 140 mm.
Concealed wall mounted basin, spout 140 mm long, with aerator.
Mitigeur lavabo encastré, aérateur, bec 140 mm.

Ref.	€	
97410	190,00	8



95154 97371 90025

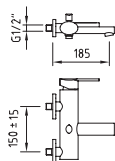

BAÑO-DUCHA

Bath-shower mixer | Mitigeur bain-douche

Mezclador baño-ducha, con aireador, inversor automático.
Bath-shower mixer, with aerator, automatic diverter.
Mitigeur bain-douche, aérateur, inverseur automatique

Incluye teléfono ducha, flexo y soporte
Includes handset, hose and holder
Inclus douchette, flexible et support
(97143, 97670, 96458)

Sin kit ducha
Without shower kit
Sans kit de douche

Ref.	€	
97403	245,00	4
97862	215,00	4



95154 97371 90027 97379

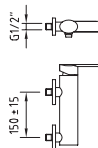

DUCHA

Shower mixer | Mitigeur douche

Mezclador para ducha.
Shower mixer.
Mitigeur douche

Incluye teléfono ducha, flexo y soporte
Includes handset, hose and holder
Inclus douchette, flexible et support
(97143, 97670, 96458)

Sin kit ducha
Without shower kit
Sans kit de douche

Ref.	€	
97404	202,00	6
97863	172,00	4



95154 97371

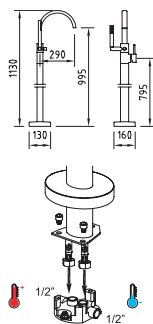

BAÑO-DUCHA FIJACIÓN SUELO | Floor standing bath-shower mixer

Mitigeur bain-douche sur colonne avec prise d'eau au sol

Baño-ducha fijación suelo con rompeaguas, inversor automático.
Floor standing bath-shower mixer, water breaker with spout, automatic diverter.
Mitigeur bain-douche sur colonne avec prise d'eau au sol, brise-jet, inverseur automatique

Incluye
Includes
Inclus



Mikura
97143

96117

Ref.	€	
97956	690,00	4



95155 97372

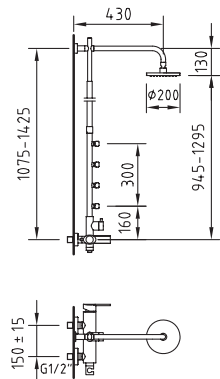

CONJUNTO DE DUCHA EXTENSIBLE 4 JETS
Extensible shower system 4 jets | Colonne mitigeur douche extensible hydromassage

Mezclador de ducha con tubo extensible, 4 jets hidromasaje y soporte integrado Mikura.
 Adjustable shower system with integral diverter and body jets.
 4 jets, support douchette fixe, inverseur automatique, pomme de douche, douchette et flexible

Incluye
 Includes
 Inclus



Ref.	€	
ec2  97417	1.030,00	2



CONJUNTO DE DUCHA TERMOSTÁTICO EXTENSIBLE 4 JETS
Extensible thermostatic shower system 4 jets | Colonne thermostatique douche extensible hydromassage

Mezclador de ducha **termostático** con tubo extensible, 4 jets de hidromasaje y soporte articulado.
 Adjustable thermostatic shower system with integral diverter and body jets.
 4 jets, support douchette orientable, inverseurs céramiques, pomme de douche, douchette et flexible.

Incluye
 Includes
 Inclus



Ref.	€	
97419	1.100,00	2

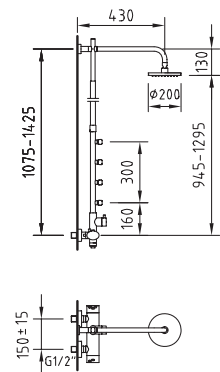

Saona

FREGADERO | Sink mixer | Mitigeur évier

Mezclador con aireador, caño giratorio, flexibles M-10 3/8" x 370 mm.
 Mixer with aerator, swivel spout, flexible hoses M-10 3/8" x 370 mm.
 Mitigeur évier bec orientable, raccords flexibles M-10 3/8" x 370 mm.

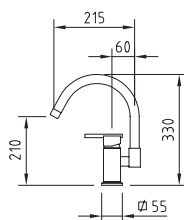

Ref.	€	
ACS  96028	154,00	6



Marina

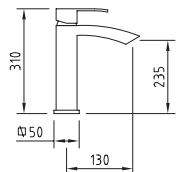

LAVABO 235 | Tall basin mixer 235 | Mitigeur lavabo 235

Mezclador alto, aireador, flexibles M-10 3/8" x 370 mm.
Tall mixer, aerator, flexible hoses M-10 3/8" x 370 mm.
Mitigeur Lavabo bec haut, aérateur, raccords flexibles M-10 3/8" x 370 mm

	Ref.	€	
	96776	243,00	6

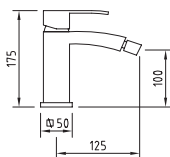

BIDÉ | Bidet mixer | Mitigeur bidet

Mezclador con aireador a rótula y flexibles M-10 3/8" x 370 mm.
Mixer, swivel aerator, flexible hoses M-10 3/8" x 370 mm.
Mitigeur bidet, aérateur rotule, raccords flexibles M-10 3/8" x 370 mm

	Ref.	€	
	96777	182,00	8

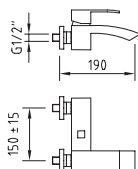

BAÑO-DUCHA | Bath-shower mixer | Mitigeur bain-douche

Mezclador baño-ducha, con aireador, inversor automático.
Bath-shower mixer, with aerator, automatic diverter.
Mitigeur bain-douche, aérateur, inverseur automatique

Incluye teléfono ducha, flexo y soporte
Includes handset, hose and holder
Inclus douchette, flexible et support
(96786, 97670, 96413)

	Ref.	€	
	96778	283,00	6

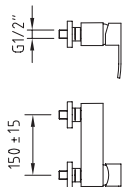

DUCHA | Shower mixer | Mitigeur douche

Mezclador para ducha.
Shower mixer.
Mitigeur douche

Incluye teléfono ducha, flexo y soporte
Includes handset, hose and holder
Inclus douchette, flexible et support
(96786, 97670, 96413)

	Ref.	€	
	96779	209,00	8

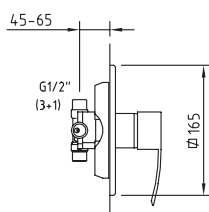

GRIFERÍA PARA DUCHA - 1 Vía Wall mounted shower mixer - 1 outlet diverter Douche à encastrer - 1 voie

Mezclador empotrable de 1/2" para ducha.
Concealed shower kit 1/2".
Douche à encastrer 1/2".

	Ref.	€	
	98444	185,00	8



Artic urban

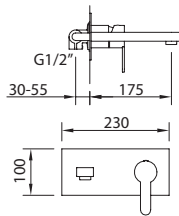

LAVABO EMPOTRAR

Concealed basin / Mitigeur lavabo à encastrer

Mezclador empotrable, caño mural con aireador, longitud 175mm.
Concealed basin, areator, wall spout length 175mm.
Mitigeur lavabo encastré, aérateur, bec 175 mm.



	Ref.	€	
ec1	98470	149,00	12

Caiman elegance

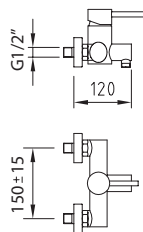

DUCHA

Shower mixer | Mitigeur Douche

Mezclador para ducha.
Shower mixer.
Mitigeur douche

Incluye teléfono ducha, flexo y soporte
Includes handset, hose and holder
Inclus douchette, flexible et support
(90796, 97114, 97113)

Sin kit ducha
Without shower kit
Sans kit de douche

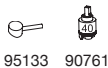

	Ref.	€	
ec1	97064	149,00	6

	Ref.	€	
ACS ec1	97870	128,00	6

Caiman urban

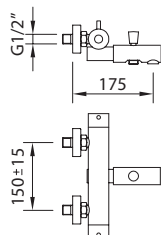
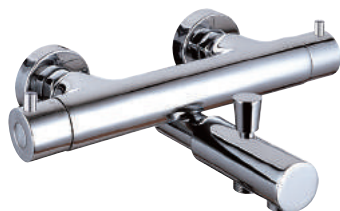

BAÑO-DUCHA TERMOSTÁTICO

Thermostatic bath-shower mixer Mitigeur bain-douche thermostatique

Mezclador termostático, aireador, inversor automático para baño-ducha.
Thermostatic bath-shower mixer, aerator, automatic diverter.
Mitigeur bain-douche thermostatique, aérateur, inverseur automatique

Incluye teléfono ducha, flexo y soporte
Includes handset, hose and holder
Inclus douchette, flexible et support
(90796, 97670, 96458)

Sin kit ducha
Without shower kit
Sans kit de douche



	Ref.	€	
	96749	299,00	4

	Ref.	€	
ACS	98160	278,00	4

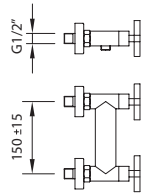

DUCHA / Shower mixer | Mitigeur Douche

Mezclador para ducha.
Shower mixer.
Mitigeur douche

Incluye teléfono ducha, flexo y soporte
Includes handset, hose and holder
Inclus douche, flexible et support
(90796, 97114, 97113)

Sin kit ducha
Without shower kit
Sans kit de douche

Ref.	€	📦
97004	155,00	6
97884	134,00	6

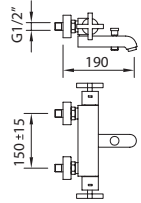
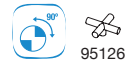

BAÑO-DUCHA TERMOSTÁTICO | Thermostatic bath-shower mixer | Mitigeur bain-douche thermostatique

Mezclador baño- ducha, aerador, inversor automático
Bath-shower mixer, aerator, automatic diverter.
Mitigeur bain-douche thermostatique, aérateur, inverseur automatique

Incluye teléfono ducha, flexo y soporte
Includes handset, hose and holder
Inclus douche, flexible et support
(90796, 97114, 97113)

Sin kit ducha
Without shower kit
Sans kit de douche

Ref.	€	📦
97012	369,00	8
98158	348,00	8

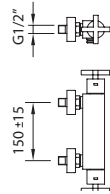

DUCHA TERMOSTÁTICA | Thermostatic shower mixer | Mitigeur douche thermostatique

Mezclador para ducha.
Shower mixer.
Mitigeur douche thermostatique
Mélangeur bain-douche, aérateur, inverseur

Incluye teléfono ducha, flexo y soporte
Includes handset, hose and holder
Inclus douche, flexible et support
(90796, 97114, 97113)

Sin kit ducha
Without shower kit
Sans kit de douche

Ref.	€	📦
97013	316,00	8
98159	295,00	8



Bahama urban

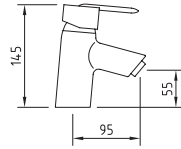

LAVABO 55 | Basin mixer 55 | Mitigeur lavabo 55

Mezclador con aireador y flexibles M-10 3/8" x 370 mm.
 Mixer, aerator, flexible hoses M-10 3/8" x 370 mm.
 Mitigeur Lavabo, aérateur, raccords flexibles M-10 3/8" x 370 mm



		Ref.	€	☐
	ec1	93528	73,00	12
	ec1	96537	81,00	12
	ec1	97915	89,00	12

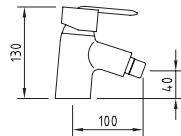

BIDÉ | Bidet mixer | Mitigeur bidet

Mezclador con aireador a rótula y flexibles M-10 3/8" x 370 mm.
 Mixer, swivel aerator, flexible hoses M-10 3/8" x 370 mm.
 Mitigeur bidet, aérateur rotule, raccords flexibles M-10 3/8" x 370 mm



		Ref.	€	☐
	ec1	93529	73,00	12
	ec1	96538	81,00	12
	ec1	97916	89,00	12

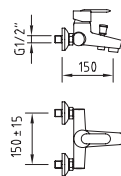
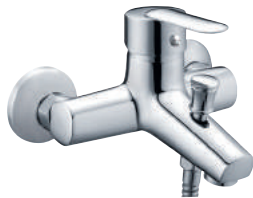

BAÑO-DUCHA | Bath-shower mixer | Mitigeur bain-douche

Mezclador baño-ducha, aireador, inversor automático
 Bath-shower mixer, aerator, automatic diverter.
 Mitigeur bain-douche, aérateur, inverseur automatique



Incluye teléfono ducha, flexo y soporte
 Includes handset, hose and holder
 Inclus douche, flexible et support
 (96108, 97670, 90011)

Sin kit ducha
 Without shower kit
 Sans kit de douche

		Ref.	€	☐
	ec1	93530	135,00	8
	ec1	97917	115,00	8

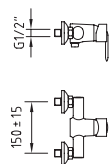

DUCHA | Shower mixer | Mitigeur Douche

Mezclador para ducha.
 Shower mixer.
 Mitigeur douche



Incluye teléfono ducha, flexo y soporte
 Includes handset, hose and holder
 Inclus douche, flexible et support
 (96108, 97670, 90011)

Sin kit ducha
 Without shower kit
 Sans kit de douche

		Ref.	€	☐
	ec1	93531	102,00	8
	ec1	97918	82,00	8

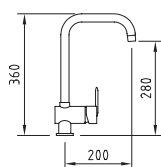

FREGADERO | Sink mixer | Mitigeur Évier

Mezclador con aireador, caño conformado giratorio y flexibles M-10 3/8" x 420 mm.
 Mixer, aerator, swivel tube spout flexible hoses M-10 3/8" x 420 mm.
 Mitigeur évier bec orientable, aérateur, raccords flexibles M-10 3/8" x 420 mm

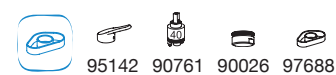

		Ref.	€	☐
	ec1	96090	143,00	8

Panam elegance

LAVABO 45 | Basin mixer 45 | Mitigeur lavabo 45

Mezclador alto con aireador y flexibles M-10 3/8" x 370 mm.
Mixer with aerator, flexible hoses M-10 3/8" x 370 mm.
Mitigeur lavabo, aérateur, raccords flexibles M-10 3/8" x 370 mm

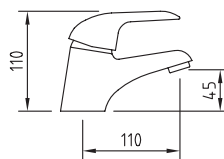

			Ref.	€	
		ec1	96340	51,00	12
		ec1	96543	59,00	12
		ec1	97939	67,00	12

BIDÉ | Bidet mixer | Mitigeur bidet

Mezclador con aireador a rótula y flexibles M-10 3/8" x 370 mm.
Mixer, swivel aerator, flexible hoses M-10 3/8" x 370 mm.
Mitigeur bidet, aérateur rotule, raccords flexibles M-10 3/8" x 370 mm

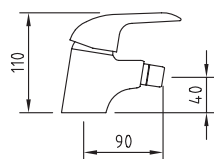

			Ref.	€	
		ec1	96341	51,00	12
		ec1	96544	59,00	12
		ec1	97940	67,00	12

BAÑO-DUCHA | Bath-shower mixer | Mitigeur bain-douche

Mezclador baño-ducha, aireador, inversor automático
Bath-shower mixer, aerator, automatic diverter.
Mitigeur bain-douche, aérateur, inverseur

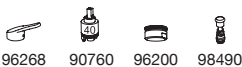
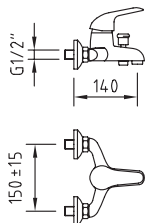

Incluye teléfono ducha, flexo y soporte
Includes handset, hose and holder
Inclus douchette, flexible et support
(98342, 97670, 90011)

Sin kit ducha
Without shower kit
Sans kit de douche

			Ref.	€	
		ec1	96342	82,00	8
		ec1	99799	72,00	8

DUCHA | Shower mixer | Mitigeur Douche

Mezclador para ducha.
Shower mixer.
Mitigeur douche

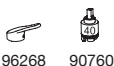
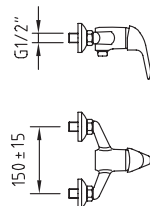

Incluye teléfono ducha, flexo y soporte
Includes handset, hose and holder
Inclus douchette, flexible et support
(98342, 97670, 90011)

Sin kit ducha
Without shower kit
Sans kit de douche

			Ref.	€	
		ec1	96343	67,00	8
		ec1	99800	57,00	8

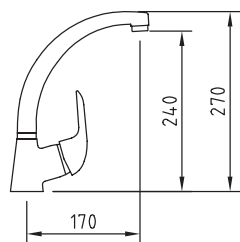

FREGADERO
Sink mixer | Mitigeur évier

Mezclador con aireador, caño conformado giratorio, flexibles M-10 3/8" x 370 mm.
Mixer with aerator, swivel tube spout, flexible hoses M-10 3/8" x 370 mm.
Mitigeur évier bec orientable, aérateur, raccords flexibles M-10 3/8" x 370 mm

Ref.	€	
ACS ec1 96344	72,00	12

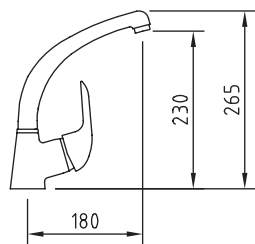

FREGADERO
Sink mixer | Mitigeur évier

Mezclador con aireador, caño fundido giratorio, flexibles M-10 3/8" x 370 mm.
Mixer with aerator, swivel cast spout, flexible hoses M-10 3/8" x 370 mm.
Mitigeur évier bec orientable, aérateur, raccords flexibles M-10 3/8" x 370 mm

Ref.	€	
ACS ec1 96345	78,00	12

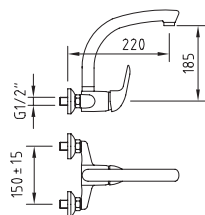

FREGADERO MURAL
Wall mounted single lever sink mixer | Mitigeur évier mural

Mezclador mural con aireador, caño conformado giratorio superior.
Wall mounted mixer with aerator, upper swivel tube spout.
Mitigeur évier mural, bec orientable façonné, aérateur

Ref.	€	
ACS ec1 96346	88,00	12



Panam xtreme

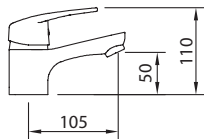

LAVABO 50 | Basin mixer 50 | Mitigeur lavabo 50

Mezclador alto con aireador y flexibles M-10 3/8" x 370 mm.
Mixer with aerator, flexible hoses M-10 3/8" x 370 mm.
Mitigeur lavabo, aérateur, raccords flexibles M-10 3/8" x 370 mm

				Ref.	€	
SYNTHETIC	ACS	ec1	[Symbol]	98141	51,00	12
				98137	59,00	12
				98138	67,00	12



95172 98237 90025

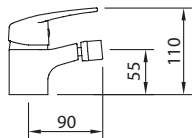

BIDÉ | Bidet mixer | Mitigeur bidet

Mezclador con aireador a rótula y flexibles M-10 3/8" x 370 mm.
Mixer, swivel aerator, flexible hoses M-10 3/8" x 370 mm.
Mitigeur bidet, aérateur rotule, raccords flexibles M-10 3/8" x 370 mm

				Ref.	€	
SYNTHETIC	ACS	ec1	[Symbol]	98142	51,00	12
				98139	59,00	12
				98140	67,00	12



95172 98237 99232

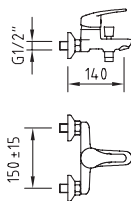

BAÑO-DUCHA | Bath-shower mixer | Mitigeur bain-douche

Mezclador baño-ducha, aireador, inversor automático
Bath-shower mixer, aerator, automatic diverter.
Mitigeur bain-douche, aérateur, inverseur

Incluye teléfono ducha, flexo y soporte
Includes handset, hose and holder
Inclus douchette, flexible et support
(98342, 97670, 98343)

Sin kit ducha
Without shower kit
Sans kit de douche

				Ref.	€	
ACS	ec1	[Symbol]	[Symbol]	98143	82,00	8
				99801	72,00	8



95172 98237 96200 98490

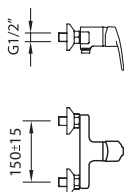

DUCHA | Shower mixer | Mitigeur Douche

Mezclador para ducha.
Shower mixer.
Mitigeur douche

Incluye teléfono ducha, flexo y soporte
Includes handset, hose and holder
Inclus douchette, flexible et support
(98342, 97670, 98343)

Sin kit ducha
Without shower kit
Sans kit de douche

				Ref.	€	
ACS	ec1	[Symbol]	[Symbol]	98144	67,00	8
				99802	57,00	8



95172 98237

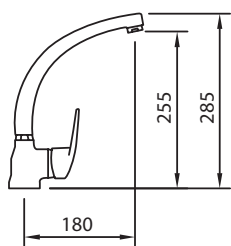

FREGADERO
Sink mixer | Mitigeur évier

Mezclador con aireador, caño conformado giratorio, flexibles M-10 3/8" x 370 mm.
Mixer with aerator, swivel tube spout, flexible hoses M-10 3/8" x 370 mm.
Mitigeur évier bec orientable, aérateur, raccords flexibles M-10 3/8" x 370 mm

	Ref.	€	
	ec1	98767	72,00 12

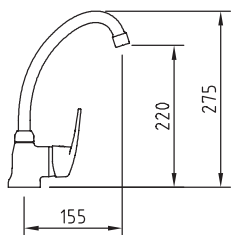

FREGADERO
Sink mixer | Mitigeur évier

Mezclador con aireador, caño conformado giratorio, flexibles M-10 3/8" x 370 mm.
Mixer with aerator, swivel tube spout, flexible hoses M-10 3/8" x 370 mm.
Mitigeur évier bec orientable, aérateur, raccords flexibles M-10 3/8" x 370 mm

	Ref.	€	
		ec1	98145 69,00 12

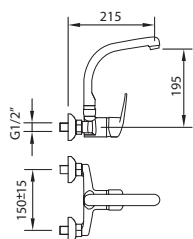

FREGADERO MURAL
Wall mounted single lever sink mixer | Mitigeur évier mural

Mezclador con aireador, caño conformado giratorio.
Mixer with aerator, swivel tube spout.
Mitigeur évier mural, bec orientable façonné, aérateur

	Ref.	€	
	ec1	98766	88,00 12

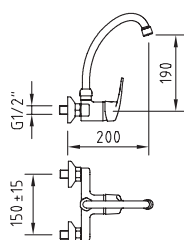

FREGADERO MURAL
Wall mounted single lever sink mixer | Mitigeur évier mural

Mezclador con aireador, caño conformado giratorio.
Mixer with aerator, swivel tube spout.
Mitigeur évier mural, bec orientable façonné, aérateur

	Ref.	€	
		ec1	98146 84,00 12



Nine urban

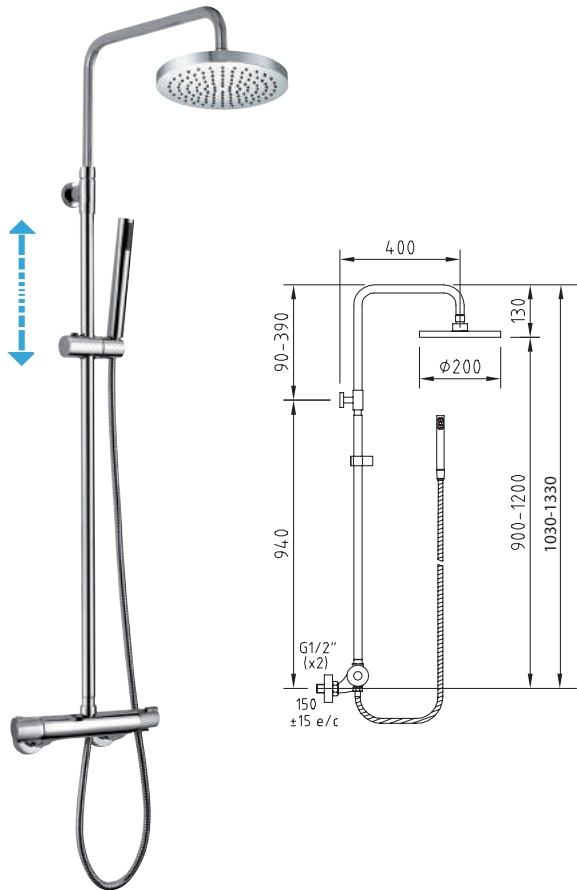

CONJUNTO DE DUCHA TERMOSTÁTICO Thermostatic shower system Colonne thermostatique douche extensible

Mezclador termostático de ducha con tubo extensible (98517), soporte articulado deslizando.
Adjustable thermostatic shower system (98517) with diverter built.
Support douchette coulissant, inverseur céramique, pomme de douche, douchette et flexible

Incluye
Includes
Inclus



Ref.	€	Q
98761	390,00	4



Inversor incorporado en la maneta de caudal
Diverter built in the flow handle
Inverseur intégré dans la poignée

Temporizados | Delay action taps | Temporisés

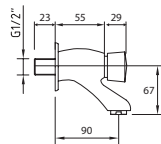

GRIFERIA TEMPORIZADA MURAL | Wall mounted delay action basin tap | Robinet temporisé mural

Grifo mural para lavabo, con aireador, 14 segundos, cartucho M28
Wall mounted basin tap, with aerator, 14 seconds, cartridge M28
Robinet simple, avec aérateur, 14 secondes cartouche M28



Ref.	€	Q
98924	30,00	40

FREGADERO COLUMNA LAVAVAJILLAS | Sink mixer with swivel spout and dishwashing shower | Mitigeur évier industriel

Fregadero columna lavavajillas, caño lateral recto con palanca, muelle resistente, ducha de pistola y flexo 47cm. Flexibles M-10 3/8" x 370 mm.
 Sink column, straight lateral spout, diverter, strong spring, dishwashing shower, hose 47cm. Flexible hoses M-10 3/8" x 370 mm.
 Évier à bec orientable, ressort de guidage renforcé, douchette avec gachette prélavage. Livré avec raccords flexibles M-10 3/8" x 370 mm

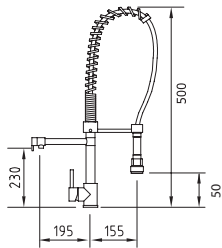

	Ref.	€	
500 mm	ec1 96771	410,00	4



95158 90761 96273 97688 90026

FREGADERO COLUMNA LAVAVAJILLAS 500 | Sink mixer with swivel spout and dishwashing shower | Mitigeur évier douchette

Fregadero columna lavavajillas, muelle resistente y ducha extraíble de pistola con 2 posiciones. Flexibles M-10 3/8" x 370 mm.
 Wash-dishes sink column, strong spring and pull-out dishwashing shower. Flexible hoses M-10 3/8" x 370 mm.
 Évier à bec orientable, ressort de guidage renforcé, douchette avec poussoir prélavage. Livré avec raccords flexibles M-10 3/8" x 370 mm

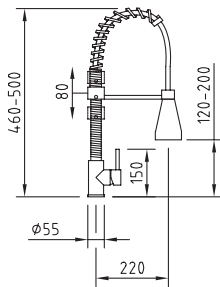

	Ref.	€	
500 mm	ec1 96755	255,00	4



95145 96205 97364 97688

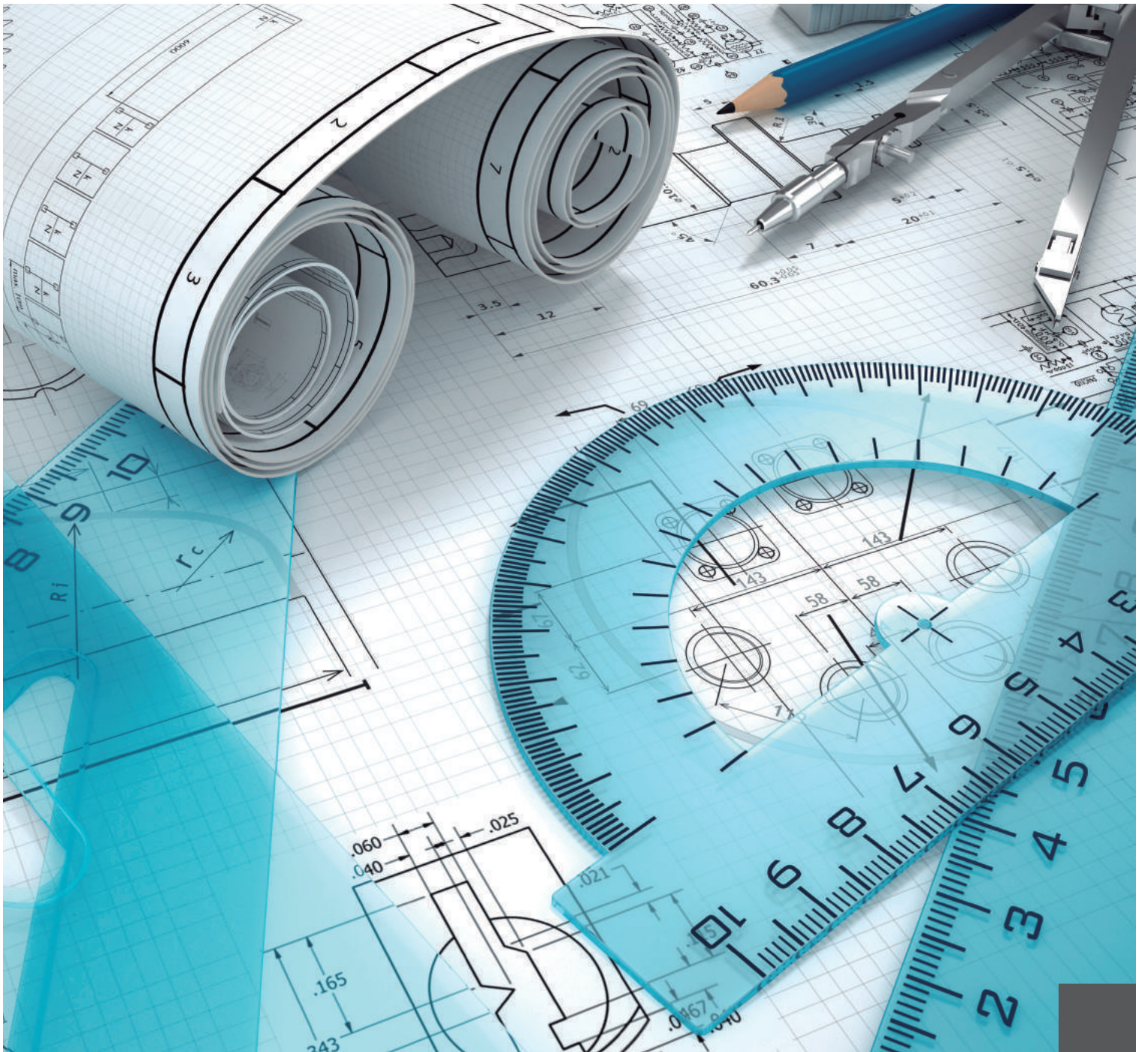

Información técnica y certificados

Technical information and certificates
Information technique et certificats

Información técnica

Technical information
Information technique

334

Certificados

Certificates
Certificats

346

LATÓN · BRASS · LAITON

FUNDIDO · CAST · FONTE



La grifería Clever utiliza aleaciones puras, con una mínima cantidad de impurezas.
El porcentaje de plomo es muy bajo ($Pb < 1,6\%$) en consonancia con las directrices de consumo de agua potable.
La aleación exenta de poros logra un pulido de alta calidad.
Ausencia total roturas.

Clever taps use pure alloys, with a minimum impurity quantity.
The percentage of lead is really low ($Pb < 1,6\%$) according to the strictest market requirements. The alloy exempts of pores allows to obtain a high quality polish.
Total breaks Absence.

La robinetterie Clever est fabriquée à partir d'alliages purs, à très faibles niveaux d'impuretés.
Très faibles pourcentage de plomb ($Pb < 1,6\%$) selon les exigences les plus strictes concernant la consommation d'eau potable.
Les alliages sans pores permettent un polissage de haute qualité.
Sans aucune fissure.

ESTAMPACIÓN · STAMPING · ESTAMPÉE



Latón europeo estampado de extrusión de primera calidad. Norma UE EN 12.164/5. El latón de estampación contiene un porcentaje muy alto de cobre ($Cu \sim 60\%$).
El porcentaje de estaño es muy bajo ($Sn < 0,3\%$), evitando la rigidez y posibles daños.

High quality European stamping Brass. According rule UE EN 12.164/15. The stamping brass has a high percentage of Cooper ($Cu \sim 60\%$).
Very low percentage of Tin ($Sn < 0,3\%$), avoids rigidity and possible damages.

Laiton européen estampé par extrusion, de première qualité. Norme UE-EN 12.164/5.
Le laiton estampé contient un fort pourcentage de cuivre ($Cu \sim 60\%$).
Très faible pourcentage d'étain ($Sn < 0,3\%$), évitant la rigidité et les possible endommagements.

COMPONENTES · COMPONENTS · COMPOSANTS

LATIGUILLLOS · HOSE BIBS · FLEXIBLES



Longitud de 370 mm, según Norma EN 817. Macho roscado fabricado con CW617 ($Sn < 0,3\%$).
Trenzado acero Inoxidable AISI 304. Tubo de goma EPDM o PEX, libre de migración de partículas nocivas.
Amplia cobertura de certificaciones internacionales. Resisten presiones estáticas de más de 130 bar (13 MPa).

Lenght 370 mm according to the rule EN 817. Male nut produced with CW617 ($Sn < 0,3\%$).
Braided stainless steel AISI 304. Rubber tube EPDM or PEX, avoiding any particles migration.
All worldwide certifications. They resist static pressures higher than 130 bars (13MPa).

Longeur 370 mm. suivant la norme EN 817. Fabriqué avec CW617 ($Sn < 0,3\%$).
Tressé en acier inoxydable AISI 304. Tuyau en caoutchouc EPDM o PEX, sans migration de particules nocives.
Tous types de certifications mondiales. Supportent des pressions statiques de plus de 130 bar (13 MPa).

AIREADORES · AERATORS · AÉRATEURS



NEOPERL®

Protección máxima contra los residuos de cal. Período de vida de larga duración.
Reducción de salpicaduras. Control de rectitud de la corriente y el diámetro del chorro de agua.
Producen un flujo recto, redondo, independiente de la presión.
Nivel de ruido mínimo. Permiten un ahorro de agua y reducen el coste energético.

Maxim protection against lime residues. Long life.
Splashes reduction. Flow straight control and water stream diameter.
It produces a straight flow, round, independent to the pressure.
Minimum noise level. It allows water save and electricity cost reduction.

Haute protection contre le tartre. Retarde l'apparition d'incrustations calcaires.
Longue période de vie. Réduction des éclaboussures.
Rectitude du courant et du diamètre indépendamment de la pression.
Niveau minimal de bruit. Permettent l'économie d'eau et la réduction du coût énergétique.

CROMADO · CHROMED · CHROMÉ



Extra Cromado, proceso de cromado compuesto por 44 pasos que garantizan la resistencia a la corrosión.
La superficie debe resistir una prueba de laboratorio que consiste en soportar más de 200 horas de niebla salina sin que se aprecien defectos.

Extra Chromed, our Chrome process is composed by 44 steps to warranty the corrosion resistance.
The surface has to resist the laboratory test which consists of withstanding > 200 hours salt spray test without appearing any defect.

Extra Chrome, procédé de chromage en 44 étapes qui garantissent la résistance à la corrosion.
La surface doit être capable de supporter des essais en laboratoire equivalents à 200 heures de brouillard salin, sans endommagements appréciables.



EXCÉNTRICA · ECCENTRIC NUT · RACCORD EXCENTRÉ

El diseño interior evita ruidos procedentes de la circulación del agua. Fabricado con CW617 (Sn<0.3%)

Un dispositivo instalado en el interior de la excéntrica absorbe el ruido del agua al pasar por ella.

Reduce el ruido alrededor de 20 decibelios.

The inner design avoids noises from the water circulation. Produced with CW617 (Sn<0.3%)

One set installed inside the eccentric nut absorbs the noise when the water flows.

Noise reduction around 20 decibels.

Sa conception intérieure évite les bruits de la circulation d'eau. Fabriqué avec CW617 (Sn <0,3%). Un dispositif absorbe le bruit de l'eau à son passage par l'excentré.

Réduit le bruit de 20 db. approx.

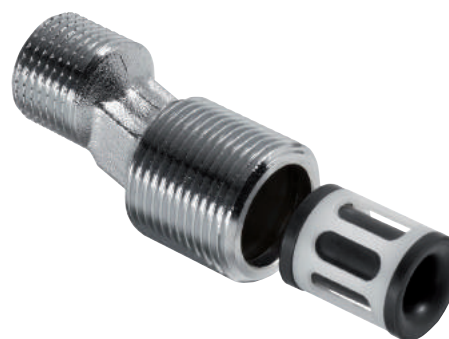

GARANTÍA CLEVER · WARRANTY · GARANTIE

Los grifos Clever han pasado estrictos controles de calidad, están fabricados con los mejores materiales y componentes con el fin de ofrecer confort y durabilidad. Es por ello que ofrecemos 5 años de garantía en TODA nuestra gama. Temporizados, 2 años.

La grifería Clever cumple con las indicaciones de las normas: UNE 19-703 / UNE 19-707 (EN 200) / UNE-EN 817 / UNE-EN 816 / UNE-EN 111, y su calidad está garantizada según la norma ISO 9001.

Clever taps have passed the strictest quality controls as all are produced with the best materials and components in order to offer the comfort and durability. Due to reason we offer 5 years guarantee in all our ranges. Delay action taps 2 years.

Clever taps carry out the following rules: UNE 19-703 / UNE 19-707 (EN 200) / UNE-EN 817 / UNE-EN 816 / UNE-EN 111, and its quality is guaranteed according to ISO 9001.

La robinetterie Clever a été soumise aux plus stricts contrôles de qualité et fabriquée à partir des meilleurs matériaux et composants.

Ceci nous permettant d'offrir 5 ans de garantie pour TOUTE la gamme. Temporisés 2 ans.

La robinetterie Clever est soumise aux normes: UNE 19-703/ UNE 19-707 (EN 200)/ UNE EN 817/ UNE EN 816/ UNE EN 111 et sa qualité est garantie selon la norme ISO 9001.



Standard

cosedal

gitec

QUORE



Se incorporan cerámicas técnicas sintetizadas de alta precisión con gran resistencia al desgaste. Todos los materiales en contacto con el agua cumplen las normas internacionales sanitarias como ACS, KTW & W270, Watermark, etc. La gran sensibilidad, nos confiere en la maneta un largo desplazamiento lateral entre 34° y 42°. Lo que nos permite obtener la temperatura deseada con exactitud.

The cartridge uses high advanced sintered ceramic disc with high resistance to wear. All material in contact with water is certified by international norms such ACS, KTW & W270, Watermark, etc. The sensibility of the handle allows us to get the temperature with exactitude.

Nous avons incorporé des céramiques techniques synthétisées de haute précision, avec une grande résistance à l'usure. Tous les matériaux en contact avec l'eau sont conformes aux normes sanitaires comme l'ACS, la KTW et la W270, Watermark, etc. L'ampleur de déplacement latéral de la manette entre 34° et 42° nous permet d'obtenir la température souhaitée avec la plus grande exactitude.

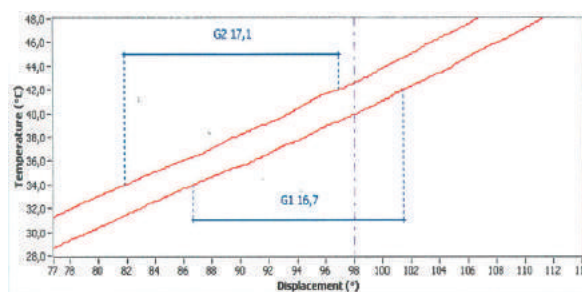

ec1

EcoNature

El sistema EcoNature consiste en un cartucho con 2 posiciones, calibrado desde fábrica, el cual ofrece un alto nivel de confort y facilidad de uso. El sistema se basa en un mecanismo situado en el interior del cartucho.

Con un suave gesto suministra el caudal necesario para el uso cotidiano del grifo (ahorrando aproximadamente un 50% en el consumo de agua), si se desea el máximo caudal hay que ejercer una ligera presión en la palanca hacia arriba hasta alcanzar el máximo recorrido de la maneta.

The EcoNature system consists of an Economizer Cartridge with two positions, assembled and calibrated in the factory, which offers a high level of comfort and it is very easy to use.

The system is based on an end located in the interior of the cartridge, with a smooth gesture provides the volume necessary to guarantee a sufficient water flow for the daily use (saving approximately a 50% in the water consumption), if the maximum volume is desired it is only necessary to rise the handle till the maximum position.

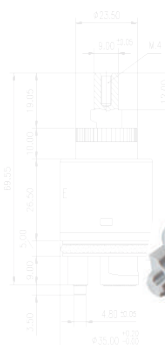

gitec



Sistema EcoNature, EcoNature system

L'EcoNature système consiste à utiliser une cartouche céramique de dernière génération équipée d'un système à 2 positions d'ouverture, assemblé et calibré en usine. Ce système permet de réelles économies d'eau et offre un grand confort d'utilisation.

Son principe de fonctionnement repose sur un dispositif d'arrêt de course du levier, localisé à l'intérieur de la cartouche et qui permet d'obtenir un débit d'eau suffisant pour une utilisation quotidienne (50% d'économie dans la consommation d'eau).

Si le débit maximum est nécessaire, il suffit de lever le levier jusqu'à sa position maximum.

ec2

EcoNature + ColdOpen

gitec



El cartucho ec3 además de incorporar el sistema EcoNature también incorpora ColdOpen, apertura en frío. Con este tipo de apertura obtendremos un ahorro no sólo en caudal, gracias al EcoNature, sino que también en agua caliente gracias a que la maneta, en su posición central, genera agua fría evitando la mezcla de caliente y fría y por lo tanto, consiguiendo un ahorro.

The ec3 cartridge a part from having Econature system also incorporates ColdOpen function, this means opening in cold. With this type of opening we get a saving not only in flow, thanks to Econature, also in hot water due to the handle in its central position that generates cold water, avoiding to mix hot and cold water from the beginning.

En plus du système EcoNature, la cartouche ec3 intègre le système ColdOpen, ouverture eau froide. Avec ce type d'ouverture, nous obtenons une économie non seulement de débit, grâce à l'EcoNature, mais aussi d'eau chaude puisque la manette, lorsqu'elle est actionnée en position centrale, ne libère que de l'eau froide sans la mélanger avec l'eau chaude, permettant ainsi une économie importante.

ec3



Sistema EcoNature, EcoNature system



Sistema ColdOpen, ColdOpen system

Termostático

Estabilidad: la temperatura permanece constante. **Confort:** compensa automáticamente los cambios de temperatura. **Seguridad:** si el suministro de agua fría se interrumpe, el cartucho no deja pasar agua caliente de inmediato y evita quemaduras. **Precisión:** grifos calibrados a 38°C. **Temperatura exacta.** **Exactitud:** cartucho sintético especial, insensible a la cal (Ca). **Trazabilidad:** marcado STH y fecha para un mayor control y seguimiento.

Stability: the temperature remains constant. Comfort: automatically compensates temperature changes. Safety: If the cold water supplied is interrupted, the cartridge will not let hot water to enter and avoid scalding. Accuracy: taps calibrated at 38 ° C. Exact Temperature. Exactitude: special synthetic cartridge, insensitive to the lime (Ca). Traceability: STH brand and date marked for a higher control and monitoring.

Stabilité: la température reste constante. Confort: les changements de température sont compensés automatiquement. Sécurité: en cas d'interruption du débit d'eau froide, la cartouche ne laisse pas passer l'eau chaude immédiatement, évitant ainsi les brûlures. Précision: les robinets sont calibrés à 38°. Température exacte. Résistance: cartouche synthétique spéciale, résistante au calcaire (Ca). Traçabilité: marquage STH et datage pour un meilleur contrôle et suivi.



cosedal





SEGURIDAD · SECURITY · SÉCURITÉ



TERMOLIMIT

Limitación temperatura
Temperature limit
Limitation de la température



Anillo situado en el cartucho que permite al usuario limitar la temperatura del agua caliente, consiguiendo ahorro energético y evitando quemaduras. Ideal para la seguridad infantil.

O-ring placed in the cartridge, which allows the end user limit the hot water temperature, saving electricity and avoiding scalds.

It is worth for the child security.

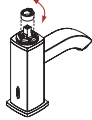

Un anneau situé sur la cartouche permet à l'utilisateur de limiter la température de l'eau chaude, obtenant ainsi une économie d'énergie et évitant les brûlures. Idéal pour la sécurité des enfants.



MEDICAL

Máxima higiene
Maximum hygiene
Hygiène maximale

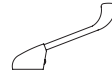

La maneta gerontológica Clever es ideal para ubicaciones dónde los requerimientos higiénicos sean elevados.

Además el usuario puede montarla en otros grifos Clever. Consultar compatibilidad con nuestro servicio técnico al cliente.

The Clever hygienic handle is suitable for those places where the hygienic requirements are high.

Moreover the end user can assembly this handle in other Clever taps. Please check with our Technical Department if it suits.

La manette hygiénique Clever, comme son nom l'indique, est particulièrement adaptée aux endroits où les normes d'hygiène sont élevées.

De plus l'utilisateur peut monter cette manette sur les autres mitigeurs Clever. Merci de vous rapprocher de notre Département Technique pour vérifier les compatibilités.



SAFETY BLOCK

Doble tope de seguridad para termostáticos
Double security system for thermostatic
Double système de sécurité pour thermostatique

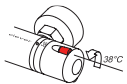

Dispositivo que evita temperaturas superiores a 38°C de manera involuntaria. El usuario debe pulsar el botón para conseguir temperaturas superiores. Ideal para la seguridad infantil. Bloqueo automático en el caso de que se interrumpa el suministro de agua fría en la instalación.

Mechanism which avoids temperatures higher than 38°C in an involuntary way. The end user has to press the button in order to get higher temperatures.

It is perfect for the child security. Automatic block in case it is stopped the cold water supply.

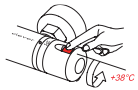

Mécanisme qui évite une température involontairement supérieure à 38°. L'utilisateur doit presser le bouton afin d'avoir des températures plus élevées. Idéal pour la sécurité des enfants. Blocage automatique en cas de baisse de pression sur le réseau d'eau froide.



MEDIO AMBIENTE · ENVIRONMENT · ENVIRONNEMENT



PUBLIC PLACE

Diseñado para lugares públicos
Designed for public places
Conçu pour les lieux publics



Las gamas de Temporizados Clever están específicamente diseñados para lugares públicos.

Automático, antivandálico, sistema inteligente de ahorro de agua y sistema de desmontaje oculto.

The series Clever of Delay Action are specially designed for Public Places.

Automatic, antivandalic, wise system to save water and hidden dismantle system.



Les séries Temporisées sont spécialement conçues pour les lieux publics.

Automatique, antivandalisme, système intelligent d'économie d'eau et système de démontage caché.



RECICLABLE

Ecológico
Ecologic
Ecologique



Clever utiliza material de embalaje reciclable en toda su gama, consciente del medio ambiente.

El proceso de fabricación es inspeccionado periódicamente, asegurando la conservación de la naturaleza.



Clever uses recycle packaging in all its range, protecting the environment.

The production process it is inspected periodically, safeguarding the nature conservation.



Clever protège l'environnement en utilisant des matériaux recyclés pour tous ses packagings.

Ce système de production mis en place pour préserver la nature est inspecté périodiquement.



NOISELESS

Dispositivo reductor de sonido
Noise reduction system
Système de réduction du bruit

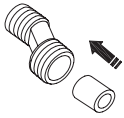

El diseño interior de nuestra grifería evita que el agua a su paso produzca ondas sonoras. Un dispositivo ubicado en las excéntricas absorbe las ondas sonoras de las aguas recibidas por la instalación.

The inner design of our taps avoid noises from the water circuit. A mechanism placed inside our eccentric nut absorbs the noises produced when the water goes through the tap.

Le design interne de nos modèles évite tout bruit provenant du circuit de l'eau.

Un mécanisme placé à l'intérieur de notre raccord excentrique absorbe les bruits produits par l'écoulement de l'eau sur le réseau.



WATER REDUCE

Sistema reducción de caudal
Flow reduction system
Système de réduction de débit



Los dispositivos reductores proporcionan un ahorro significativo del consumo de agua en grifos y mangos de ducha. El caudal máximo se verá reducido a 9 litros x minuto.

The reducing devices provide a significant water saving consumption in taps and shower handles. The maximum volume will be reduced to 9 liters x minute.

Les dispositifs réducteurs offrent une économie significative de la consommation d'eau pour les robinets et les douchettes. Le débit maximum est réduit à 9 litres x minutes.



PURE H₂O

Grifería para osmosis
Filter sink mixer
Robinet eau pure osmosis

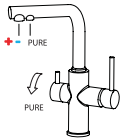

Un grifo con 2 salidas: agua corriente y agua pura de ósmosis.

Mixer with two exits: tap and filter water.

Un robinet avec deux sorties: eau courante et eau purifiée.

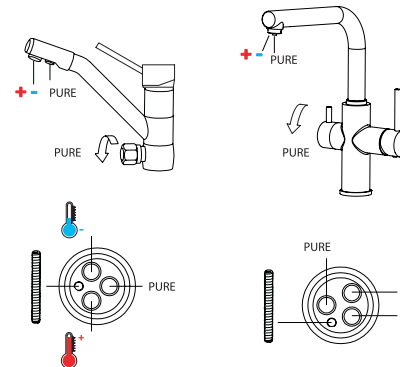

TECNOLOGÍA · TECHNOLOGY · TECHNOLOGIE

ec1

Cartucho ec1
ec1 cartridge
Cartouche ec1

Se incorporan cerámicas técnicas sintetizadas de alta precisión con gran resistencia al desgaste. Todos los materiales en contacto con el agua cumplen las normas internacionales sanitarias como ACS, KTW & W270, Watermark, etc.

Synthesized high precision technical ceramics with high resistance to the corrosion are incorporated. All materials in contact with water complied with international standards such as sanitary ACS, KTW & W270, Watermark, etc.

Nous avons incorporé des céramiques techniques synthétisées de haute précision, avec une grande résistance à l'usure. Tous les matériaux en contact avec l'eau sont conformes aux normes sanitaires comme l'ACS, la KTW et la W270, Watermark, etc.



ec2

Cartucho ec2
ec2 cartridge
Cartouche ec2



El sistema EcoNature consiste en un cartucho con 2 posiciones, calibrado desde fábrica, el cual ofrece un alto nivel de confort y facilidad de uso. El sistema se basa en un mecanismo situado en el interior del cartucho.

The Econature system consists on a cartridge with 2 positions, calibrated at the factory, which offers a high level of comfort and ease use. The system is based on a mechanism located inside the cartridge.

L'EcoNature système consiste à utiliser une cartouche céramique équipée d'un système à 2 positions d'ouverture, assemblée et calibrée en usine. Ce système permet de réelles économies d'eau et offre un grand confort d'utilisation.



ec3

Cartucho ec3
ec3 cartridge
Cartouche ec3



El cartucho ec3 además de incorporar el sistema EcoNature también incorpora ColdOpen, apertura en frío. Consiguiendo un ahorro en agua caliente gracias a que la maneta, en su posición central, genera agua fría evitando la mezcla de caliente y fría.

The ec3 cartridge a part from having Econature system also incorporates ColdOpen function, this means opening in cold. Achieving savings in hot water thanks to the lever in the center position, it generates cold water avoiding any mixing.

En plus du système EcoNature, la cartouche ec3 intègre le système ColdOpen, ouverture eau froide. Avec ce type d'ouverture, nous obtenons une économie non seulement d'eau, grâce à l'EcoNature, mais aussi d'énergie.



WATERFALL

Efecto cascada
Waterfall effect
Effet cascade

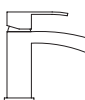

El efecto WATERFALL proporciona un cambio en la concepción de la grifería. Sin aireador, el grifo realza su estética y reproduce la fuerza intacta de la naturaleza.

Effect WATERFALL provides a change in the taps conception. Without aerator, the faucet heightens its aesthetic one and reproduces the intact force of the nature.

L'effet WATERFALL modifie le concept de la robinetterie traditionnelle.

Sans aérateur, l'esthétique du robinet est rehaussé, la force de la nature est reproduite.





AIR FORCE
Aireadores de última generación
Last generation aerators
Aérateurs de dernière génération



Clever utiliza aireadores de última generación y de prestigiosa firma internacional. El aireador mezcla aire y agua evitando salpicaduras. El ahorro de agua está asegurado.

Clever uses in all ranges last aerators generation and prestigious international company. The aerator mix air and water. It avoids the splashes on the washbasin. The water saving is assured.

Clever utilise pour toutes ses gammes des aérateurs de dernière génération, de prestigieuses entreprises internationales. L'aérateur mélange l'air et l'eau et permet d'éviter les projections sur le lavabo et sur les autres surfaces. L'économie d'eau est assurée.



PULL-OUT
Grifería extraíble
Pull-out taps
Robinetterie extractible

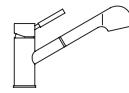

Grifería de cocina con mango extraíble.

Mixer with pull-out spout.

Robinet d'évier à douchette extractible.



SUPERFIX
Anti-movimiento para fregaderos
Stop movement for sink mixer
Renfort pour éviers



Los grifos de cocina Clever disponen de una base que se coloca en la parte inferior de los fregaderos de acero inoxidable, evitando el movimiento del grifo al accionarlo.

The Clever sink taps have available a base which is placed in the inferior part of the stainless steel taps, not allowing the mixer's movement.

Les robinets d'évier Clever disposent d'une base qui se place sur la partie inférieure des éviers en acier inoxydable, évitant ainsi la déformation de l'évier.



EASY FIX
Fácil instalación de fregaderos
Easy sink taps installation
Facilité d'installation des éviers

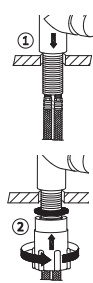

Dispositivo que permite el montaje con la mano, sin la necesidad de emplear herramientas.

Device that allows the assembly by hand, without any tools.

Dispositif qui permet le montage sans besoin d'outil spécifique.



MIRROR EFFECT
Pulido espejo
Mirror effect
Polissage miroir

El desbaste y pulido de la gama VENTU, MARINA EVO y SELENE se realiza mediante tecnología CNC, obteniendo una planicidad de efecto espejo.

The surface polished for VENTU, MARINA EVO and SELENE range is produced using the CNC technology, getting perfect flat sides with mirror effect.

L'application de la technologie CNC au dégrossissage et polissage de la gamme VENTU, MARINA EVO et SELENE permet l'obtention d'une surface plane à effet miroir.



ANTISPLASH SYSTEM
Anti salpicaduras
Anti-splash
Anti-éclaboussures

Clever ha desarrollado un sistema que disminuye las salpicaduras para fregaderos sin aireador.

Clever has developed a system which reduces the splashes when using sinks without aerator.

Clever a développé un système qui diminue les éclaboussures des éviers dépourvus d'aérateur.



CERAMIC CONTROL
Discos cerámicos
Ceramic disc
Disques céramiques

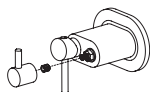

Las monturas ON-OFF son de giro 90° con discos cerámicos, óxido de aluminio de pureza 99%, indigestables. Para disminuir la conducción calorífica se monta un aislante térmico para evitar las quemaduras al accionar el pomo.

The headwork ON-OFF have a 90° turn with ceramic discs, aluminum oxide with a 99% purity, surviving the time going. In order to reduce the high temperature, a thermal insulator it is assembled to avoid scalding when you touch the handle.

Les disques ON-OFF pivotent à 90° sur disque céramique, oxyde d'aluminium pur 99%, inusable dans le temps. Pour diminuer la conduite de la chaleur et les brûlures durant l'usage, un isolant thermique est monté.



ANTI CAL
Dispositivo anti-cal
Anti lime
Dispositif anticalcaire



Todos los elementos en contacto con el agua utilizados por nuestra grifería son de materiales anti calcáreos. Se evita la obstrucción de mecanismos y la disminución de presión, y también el deterioro o el propio desperfecto de la grifería.

All the elements used in our taps which are in contact with the water are anti lime. We avoid obstruct mechanisms and water reduction, and also deteriorate or damage itself the mixer.

Tous les éléments en contact avec l'eau utilisés pour notre robinetterie sont en matière anticalcaire. L'obstruction des sorties d'eau est évitée.



HIDE DIVERTER
 Inversor diseño
 Design diverter
 Inverseur Design



Las series VENTU, MARINA EVO, AUDE, ARTIC URBAN y CAIMAN XTREME utilizan un inversor innovador, mezclando estética y funcionalidad, dónde el pomo inversor es invisible. El accionamiento consiste en desplazar el flexible de forma vertical para efectuar el cambio.

The series VENTU, MARINA EVO, AUDE, ARTIC URBAN and CAIMAN XTREME uses a new diverter, mixing style and function, where the diverter is hidden.

When the hose bib is pulled out vertically you do the change.



Les nouvelles séries VENTU, MARINA EVO, AUDE, ARTIC URBAN et CAIMAN XTREME brevetées utilisent un inverseur innovateur, mélange d'esthétique et de fonctionnalité, où l'inverseur est invisible. Pour l'actionner, il suffit de tirer le flexible de douche vers le bas.



JET MASSAGE
 Grifería con jets de hidromasaje
 Mixer with hydromassage jets
 Robinetterie à jets hydromassants

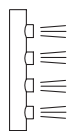

La gama MIKURA permite orientar los jets. Aconsejamos mirar con detalle las medidas de los extensibles, a fin de colocar los jets en la altura correcta.

Range MIKURA allows to position the jets. We advise to see carefully the extensible bars measures, in order to place jets in the correct height.

Confort et plaisir, une valeur ajoutée à notre robinetterie. La gamme MIKURA dispose de jets orientables. Nous conseillons de toujours bien vérifier les cotes du produit, afin de placer les jets à bonne hauteur.



EXTRA LENGHT
 Flexible 1,75m
 Hose bib 1,75 m
 Flexibles 1,75m

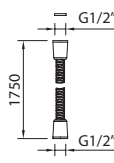

Clever utiliza flexibles de 1,75m de longitud en todos sus extensibles, duchas y baños duchas. Útil para personas de todas las estaturas.

Clever uses 1,75m hose bib length, for all showers, bath-showers. Useful for people all heights.

Clever utilise des flexibles de 1,75 m de longueur pour tous ses modèles de douches et bains-douches. Adapté aux personnes de toutes statures.



COLD TOUCH
 Grifería anti-quemaduras
 Anti-scald
 Robinetterie anti-brûlures

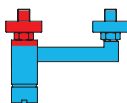

El diseño especial de nuestras duchas y baño-ducha con COLD TOUCH, permiten que en ningún caso el cuerpo se caliente y queme. Ideal para la seguridad infantil.

The special design in our Showers and Bath-Showers with COLD TOUCH, makes that the body will not have temperature and will not scald. Ideal for the child security.

Le design spécial COLD TOUCH évite que les corps de nos douches et bains douches ne chauffent et ne brûlent. Idéal pour la sécurité des enfants.

THERMOSTATIC COLD TOUCH



98823 - 98478 NINE



STANDARD SYSTEM

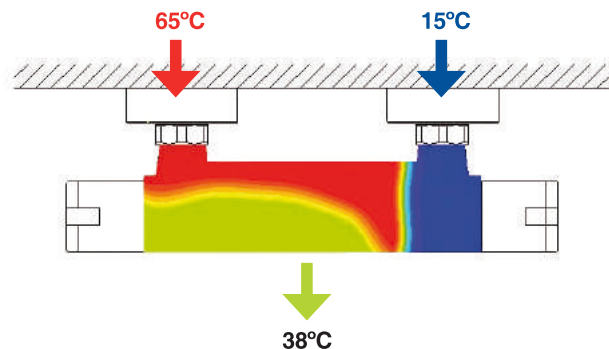

COLD TOUCH SYSTEM

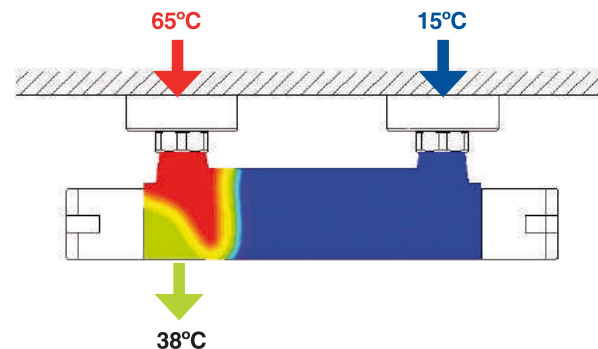



ORIENTABLE
Aireador orientable
Easy sink taps instalation
Aérateur orientable

Aireador que permite orientar el chorro de agua hasta la dirección deseada, consiguiendo así un mayor confort.

Aerator that allows to orientate the stream of water to the desired direction, thereby achieving a greater comfort.

Aérateur qui permet d'orienter le jet de l'eau pour un meilleur confort.



ULTRA SLIM
Aireador Ultra Slim
Ultra Slim aireator
Aérateur Ultra Slim

Aireador enrasado que proporciona personalidad y elegancia al grifo.

Flush aerator providing character and elegance to the faucet.

Aérateur fin qui donne de l'elegance au robinet.



COLD OPEN
Grifería de apertura en frío. Ahorro energético
Cold Open - Energy savings
Robinetterie avec système d'ouverture en eau froide. Economie d'énergie.

El sistema Cold open permite ahorrar agua caliente gracias al funcionamiento de la maneta. En su posición central, a diferencia del resto de grifería, no mezcla agua caliente y fría sino que el agua es solo fría. Para obtener agua caliente o templada se debe girar la maneta hacia la izquierda.

The Cold open system allows to save hot water thanks to the operation of the handle. In its central position, unlike the rest of the taps, it does not mix hot and cold water, the water is only cold. To obtain hot or warm water, turn the handle to the left.

Le système Cold Open permet d'effectuer des économies d'eau chaude grâce au fonctionnement de la manette. En position centrale, à la différence des autres manettes, celle-ci ne libère que de l'eau froide, sans la mélanger à de l'eau chaude. Pour obtenir de l'eau tiède ou chaude, il faut tourner la manette vers la gauche, comme indiqué.



DISEÑO Y CALIDAD · DESIGN & QUALITY · DESIGN ET QUALITÉ



TOP WARRANTY
Garantía calidad 5 años
5 years warranty
Garantie qualité 5 ans

La grifería Clever se somete a estrictos controles de calidad, es por ello que ofrecemos 5 Años de garantía en todas nuestras gamas.

Clever taps are proved under strict quality controls, is for this reason that we offer 5 years guarantee in all our ranges.

Les produits Clever subissent des contrôles qualité stricts, nous permettant de vous offrir une garantie de 5 ans sur toutes nos gammes.



TOP WARRANTY
Garantía calidad 2 años
2 years warranty
Garantie qualité 2 ans

La grifería Clever se somete a estrictos controles de calidad, es por ello que ofrecemos 2 Años de garantía en todos nuestros accesorios.

Clever taps are proved under strict quality controls, is for this reason that we offer 2 years guarantee in all our accessories.

Les produits Clever subissent des contrôles qualité stricts, nous permettant de vous offrir une garantie de 2 ans sur tous nos accessoires.



PATENTED

Diseño exclusivo y patentado
Exclusive and patent design
Design exclusif et breveté



Patented

Clever patenta sus diseños en la entidad oficial de registros de dibujos y marcas. Es nuestra distinción y el camino hacia el futuro. Las series AUDE, ARTIC urban, PAULA, S12 elegance, xtreme y urban, PANAM xtreme, START elegance y xtreme, TOUAREG y OASIS son exclusivas para los 27 países de la Unión Europea.

Clever patents its designs at the official draws and marks registration. It is our distinction and the way towards the future. The series AUDE, ARTIC urban, PAULA, S12 elegance, xtreme y urban, PANAM xtreme, START elegance y xtreme, TOUAREG and OASIS are exclusive for the 27 UNION EUROPEAN COMMUNITY countries.

Clever brevète ses designs auprès des autorités compétentes afin de protéger ses signes distinctifs et aussi d'avancer vers le futur. Les séries AUDE, ARTIC urban, PAULA, S12 elegance, xtreme y urban, PANAM xtreme, START elegance y xtreme, TOUAREG et OASIS sont déposées dans les 27 pays de l'Union Européenne.



BAG PROTECT

Funda algodón protectora
Cotton cover bag
Housse protectrice en coton



Todas las gamas Clever disponen de una funda protectora, que además de garantizar la calidad del producto una vez llega a manos del usuario, permite proteger el grifo en su ubicación definitiva hasta que las obras hayan terminado.

All Clever ranges have a protective cover, which besides guaranteeing the product quality, once arrives at the user hands allows to protect the mixer in its definitive place till the works have been finished.

Toutes les gammes Clever ont une protection qui en plus de garantir la qualité du produit permet de protéger le mitigeur jusqu'à ce que l'installation dans son emplacement final soit terminée.



MATERIALES · MATERIALS · MATÉRIAUX

Pb < 1,6%



Sn < 0,3%

HEALTH BRASS

Bajo contenido de Plomo
Low percentage of lead
Faible teneur en plomb

El bajo contenido de Plomo en las aleaciones metálicas nos permite conservar el medio ambiente y comercializar nuestros productos en estrictos mercados.

Low lead content in the metallic alloys, it allows us to take care of the environment and also being able to sell our products to the most strict markets.

La faible teneur en plomb dans les alliages métalliques nous permet de préserver l'environnement et également de vendre nos produits sur les marchés les plus exigeants.



EXTRA CHROME

Alta calidad cromado
High quality chrome
Chromage de grande qualité

El proceso de cromado consta de 44 etapas, consiguiendo 4 capas en la superficie del latón, garantizando 200 horas de niebla salina sin presentar defecto alguno.

The Chrome plated process takes 44 stages, obtaining 4 brass coats, guarantee 200 hours salty mist without showing any damage.

Le procédé de chromage se fait en 44 étapes selon les normes les plus strictes, garantissant 200 heures d'exposition au brouillard salin.



EXTRA BRASS

Latón de alta calidad
High quality brass
Laiton de haute qualité

Latón de acuerdo Normas Europeas EN 12.164 / 5. El latón de fundición es una aleación con pocas impurezas y sin poros. El latón forjado (estampación) se obtiene por extrusión, con altos porcentajes de Cobre (60%) que le dan gran elasticidad. El bajo contenido de Estaño evita incidencias producidas por fatiga. Los elementos clave de nuestra grifería utilizan Latón CW617, aleación de gran resistencia y durabilidad.

Brass according to European standard EN 12.164/5. Casting brass is an alloy with few impurities and without pores. Brass forged (stamping) is obtained by extrusion, with high copper levels (60%) which give great elasticity. The low Tin content avoids incidences produced by fatigue. All the main taps parts use brass CW617, which has a great resistance and durability.

Laiton aux normes européennes EN 12.164 / 5. Le laiton utilisé pour la fonte est un alliage avec très peu d'impuretés. Le laiton forgé (estampé) s'obtient par extrusion, avec de hauts pourcentages de cuivre (60%), qui lui donnent une grande élasticité. La faible proportion d'étain évite les problèmes dérivés de l'usure. Les éléments sensibles et ceux en contact avec leau sont fabriqués avec du laiton CW617, alliage de grande résistance et durabilité.

Termostáticos

Thermostatics / Thermostatique

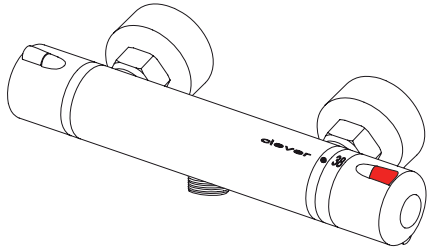

CUANDO INSTALAMOS LOS GRIFOS TERMOSTÁTICOS

- (1) Deben purgarse cuidadosamente las tuberías para eliminar arena y partículas sólidas del interior.
- (2) Es IMPRESCINDIBLE colocar los filtros en las entradas del agua fría y caliente.
- (3) Es IMPRESCINDIBLE que la toma del agua caliente esté situada a la izquierda y la del agua fría a la derecha.
- (4) PRESIÓN: Evitar que la presión del agua sea inferior a 1 bar o superior a 10 bar. La presión aconsejable es de 3 a 5 bar.
- (5) Usar calderas eléctricas de máxima capacidad posible, mínimo 200 litros, o calderas de gas con un caudal mínimo de 11 litros por minuto. Calderas de gas pequeñas (6 litros por minuto) no permitirán que el grifo funcione apropiadamente.
- (6) Recomendamos aislar térmicamente las tuberías del agua caliente.
- (7) Recomendamos instalar tuberías de diámetro mínimo 15mm

WHEN INSTALLING THERMOSTATIC TAPS

- (1) Water outlets have to be carefully cleaned to eliminate sand and dirty from inside them.
- (2) It's indispensable to place the filters in the cold and hot inlets.
- (3) It's INDISPENSABLE to place hot water inlet in left side and cold water inlet in the right side.
- (4) PRESSURE: Avoid installing these thermostatic taps when the water pressure is less than 1 bar or more than 10 bar. The recommended pressure is between 3 to 5 bar.
- (5) Use electric heaters with as much capacity as possible, minimum 200 liters, or gas heaters with a minimum capacity of 11 liters per minute. Small gas heaters (6 liter per minute) will not allow the thermostatic tap to work properly.
- (6) We recommend thermal isolation for the hot water pipes.
- (7) We recommend installing pipes with a minimum diameter of 15 mm.

A L'INSTALLATION DE LA ROBINETTERIE THERMOSTATIQUE

- (1) Il faut d'abord purger soigneusement la canalisation afin d'éliminer le sable et toutes particules solides.
- (2) Il est indispensable de placer les filtres aux entrées d'eau chaude et froide.
- (3) Il est indispensable que la prise d'eau chaude soit située à gauche, et la prise d'eau froide à droite.
- (4) Pression: Il faut éviter une pression de l'eau inférieure à 1 bar ou supérieure à 10 bar. Il est conseillé une pression de 3 à 5 bar. Il est d'autre part recommandé que la différence de pression entre eau chaude et eau froide ne soit pas supérieure à 1 bar.
- (5) Utiliser un chauffage électrique avec la capacité la plus importante possible, minimum 200 litres, ou un chauffage au gaz avec un débit minimum de 11 litres par minute. Les petits chauffages au gaz (6 litres par minute) ne permettent pas un fonctionnement optimal de la robinetterie.
- (6) Nous recommandons une isolation thermique de la tuyauterie eau chaude.
- (7) Nous recommandons l'installation de tubes d'un diamètre minimum de 15 mm.

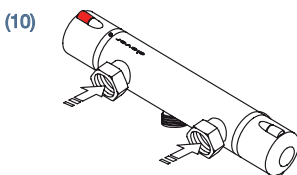
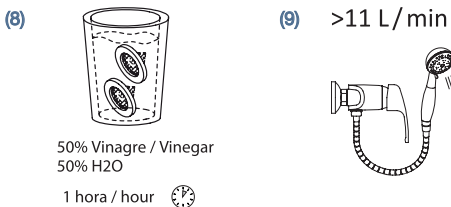
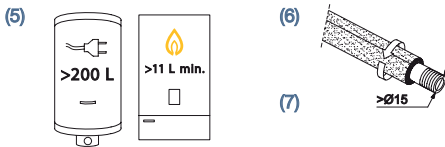
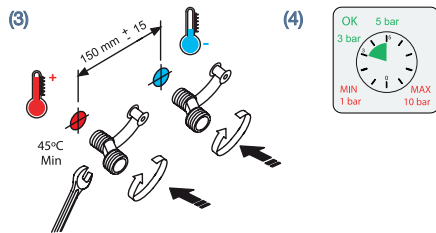
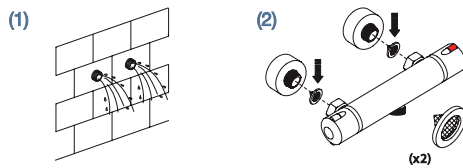

MANTENIMIENTO

- (8) Es necesario limpiar periódicamente los filtros, especialmente si el caudal disminuye injustificadamente, o si la temperatura no puede regularse bien.
- (9) Si el grifo termostático no trabaja correctamente, comprobar el caudal, debe ser superior a 11 litros por minuto.
- (10) Si toda la instalación no funciona correctamente, comprobar las válvulas anti retorno situadas en ambas entradas.

MAINTENANCE

- (8) It's necessary to clean regularly the filters, especially if the flow-rate decrease unjustifiably, or if temperature cannot be regulated properly.
- (9) If the thermostatic faucet doesn't work correctly, please check the flow-rate, there should be at least 11 liters per minute.
- (10) If the whole installation does not work appropriately, check the two check-valves placed in both inlets.

ENTRETIEN

- (8) Il est nécessaire de nettoyer périodiquement les filtres, spécialement si le débit diminue de manière injustifiée, ou si la température ne peut être correctement réglée.
- (9) Si la robinetterie thermostatique ne fonctionne pas correctement, il faut dans un premier temps vérifier le débit qui doit être supérieur à 11 litres par minute.
- (10) Si l'installation complète ne fonctionne pas, vérifier les valves anti retour situées sur chaque entrée.

Cambio cartucho

Change cartridge / Changement de cartouche

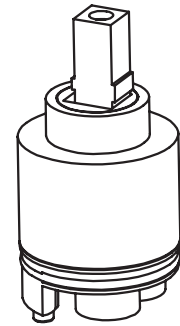
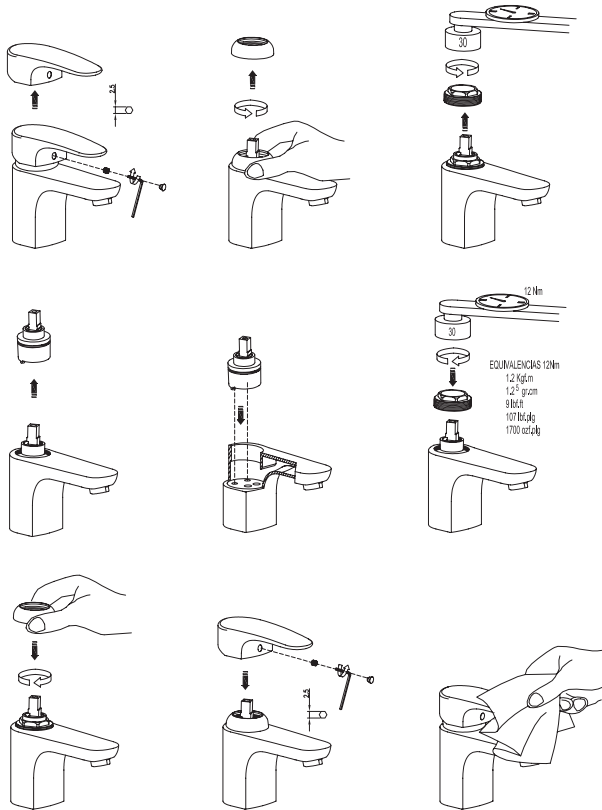

1. Sacar tornillo
2. Sacar maneta, desenroscar embellecedor
3. Sacar embellecedor, desenroscar tuerca
4. Sacar tuerca
5. Sacar cartucho, limpiar interior grifo
6. Cambiar cartucho, montar piezas.

1. Remove screw
2. Remove handle, unscrew the rosette
3. Remove the rosette and unscrew the nut
4. Remove nut
5. Cartridge Remove, clean inside faucet
6. Replace cartridge, assemble parts.

1. Retirer la vis
2. Retirer la manette, dévissier la couverture
3. Retirer la couverture, puis dévissier l'écrou
4. Retirer l'écrou
5. Retirer la cartouche, nettoyer l'intérieur du robinet
6. Changer la cartouche, monter les pièces.

Mantenimiento / Maintenance / Entretien

MANTENIMIENTO

1. Limpiar con detergente líquido.
 2. Utilizar una esponja, gamuza o paño suave.
 3. Aclarar la grifería con agua.
 4. Secar después de cada uso.
 5. NO utilizar productos ácidos o abrasivos (HCl, HNO₃, H₂SO₄...). Totalmente desaconsejado productos que contengan HCl, ácido clorhídrico (sulfumán), destruye el cromo en pocos segundos.
 6. NO utilizar ningún tipo de estropajo.
- Nuestra garantía no cubrirá los daños ocasionados por un uso inadecuado.**

MAINTENANCE

1. Clean with liquid detergent.
 2. Use a sponge, suede or soft flannel.
 3. Rinse the tap with water.
 4. Dry after every use.
 5. DO NOT use acids or abrasive products (HCl, HNO₃, H₂SO₄...). Products containing HCl, hydrochloric acid (muriatic acid) must be completely avoided, they destroy chrome in few seconds.
 6. DO NOT use any type of scouring pad.
- Our guarantee does not cover damage caused by any inappropriate use.**

ENTRETIEN

1. Nettoyer avec un détergent liquide.
 2. Utiliser une éponge, une peau de chamois ou un chiffon doux.
 3. Rincer la robinetterie à l'eau.
 4. Sécher après chaque utilisation.
 5. NE pas utiliser de produits abrasifs (HCl, HNO₃, H₂SO₄...). Les produits contenant du chlorure d'hydrogène HCl ou de l'acide chlorhydrique détruisent le chrome en quelques secondes.
 6. NE pas utiliser n'importe quel type d'éponge.
- Notre garantie ne couvrira pas les dommages occasionnés par un usage inadéquat.**

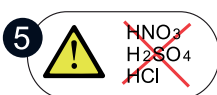
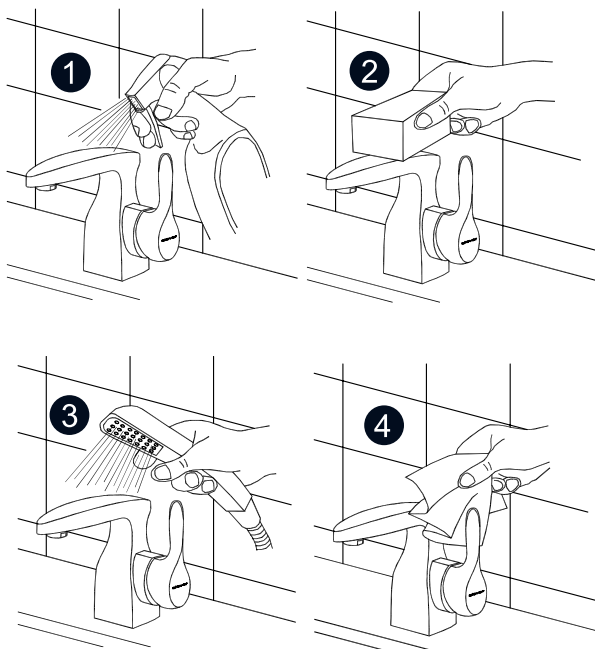



GRIFERIA CERTIFICADA Approved taps · Robinetterie certifiée

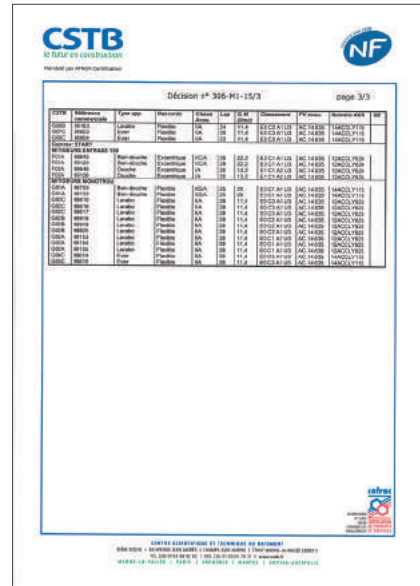
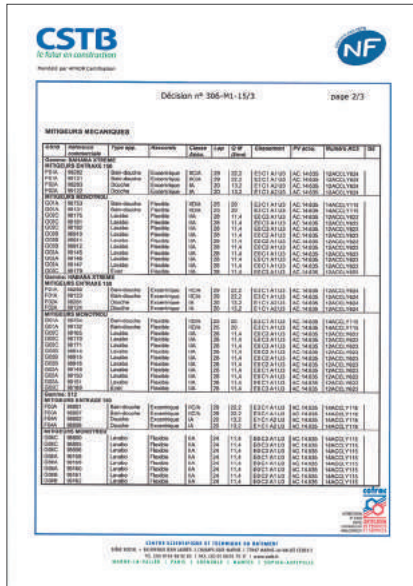

GRIFERIA CERTIFICADA Approved taps · Robinetterie certifiée



199	35162	1,23	222
199	35163	1,48	222
199	35164	0,89	222
2	35175	1,29	222
48	35176	1,48	222
0,48	35178	5,48	18,00 222
10,48	35179	0,89	222
10,48	35180	7,51	201
10,48	35181	9,15	201
13,47	35182	12,73	201
15,73	35184	5,35	18,00 201
2	35185	7,75	201
03	35187	7,75	201
4804	35188	10,95	201
34805	35189	14,75	201
34806	35190	4,65	18,00 201
34842	35191	5,40	18,00 201
34844	35192	5,40	18,00 201
34867	35193	4,40	18,00 201
34868	35195	6,23	223
34869	35196	0,99	18,00 200
34870	35210	6,44	200
34871	35211	8,71	200
	35212	15,82	205
	35218	5,61	205
	35221	7,82	193

Índice de referencias y Condiciones de venta

Item directory and Sales conditions
Index des références et Conditions de vente

Índice de referencias
Item directory
Index des références
350

Condiciones de Venta
Sales conditions
Conditions de vente
356

Índice referencias

Item directory
Index des références

Ref.	€	Pág.
31221	5,00	219
31222	12,00	219
31223	9,00	219
31224	1,70	219
31225	1,70	219
31226	77,00	219
31227	84,00	219
40010	13,00	296
40011	13,00	296
60100	129,00	54
60101	137,00	54
60102	145,00	54
60103	173,00	54
60106	129,00	56
60107	137,00	56
60108	145,00	56
60109	182,00	56
60110	161,00	56
60111	151,00	56
60112	130,00	56
60113	169,00	56-182
60114	19,00	300
60115	147,00	36
60116	155,00	36
60117	163,00	36
60118	199,00	36
60121	147,00	37
60122	155,00	37
60123	163,00	37
60124	238,00	37
60125	207,00	37
60126	202,00	37
60127	171,00	37
60128	177,00	37-179
60129	19,00	300
60130	17,00	300
60131	342,00	49-278
60132	311,00	49-278
60133	290,00	49-278
60134	259,00	49-278
60135	512,00	48-284
60139	17,00	301
60141	160,00	177
60142	269,00	174
60143	191,00	173
60144	212,00	173
60145	212,00	172
60146	212,00	172
60147	228,00	172
60148	228,00	172
60149	11,00	302
60150	179,00	164
60151	207,00	164
60152	169,00	167
60153	16,00	302
60154	383,00	45-278
60155	16,00	302
60156	76,00	251
60157	50,00	253
60158	43,00	254
60159	50,00	257
60160	35,00	258
60161	155,00	66-184
60162	223,00	65
60170	69,00	92
60171	77,00	92
60172	85,00	92
60173	80,00	92
60174	88,00	92
60175	96,00	92

Ref.	€	Pág.
60176	69,00	93
60177	77,00	93
60178	85,00	93
60179	120,00	94
60180	105,00	94
60181	98,00	94
60182	83,00	94
60183	87,00	94-189
60184	106,00	94-189
60185	69,00	96
60186	77,00	96
60187	85,00	96
60188	80,00	96
60189	88,00	96
60190	96,00	96
60191	69,00	97
60192	77,00	97
60193	85,00	97
60194	120,00	97
60195	105,00	97
60196	98,00	97
60197	83,00	97
60198	100,00	98-189
60301	37,00	223
60302	18,00	233
60303	58,00	224
60304	29,00	233
60305	62,00	225
60306	37,00	223
60307	18,00	231
60308	507,00	221
60310	19,00	300
60311	5,50	235
60312	17,00	301
60313	17,00	301
60314	31,00	304
60315	21,00	298
60316	21,00	298
60317	21,00	298
60318	21,00	298
60325	169,00	141-279
60326	154,00	141-279
60327	431,00	143-285
60328	400,00	144-287
60412	420,00	241-285
60413	389,00	241-286
60414	158,00	140-278
60415	143,00	140-278
60416	5,50	301
60417	6,50	301
60418	14,00	247-297
60500	53,00	113
60501	61,00	113
60502	69,00	113
60503	63,00	113
60504	71,00	113
60505	79,00	113
60506	53,00	114
60507	61,00	114
60508	69,00	114
60509	85,00	114
60510	75,00	114
60511	70,00	114
60512	60,00	114
60513	75,00	116-191
60514	91,00	116-196
60516	67,00	116-194
60517	320,00	115-291
60518	75,00	115
60519	116,00	115

Ref.	€	Pág.
60520	53,00	109
60521	61,00	109
60522	69,00	109
60523	63,00	109
60524	71,00	109
60525	79,00	109
60526	53,00	110
60527	61,00	110
60528	69,00	110
60529	85,00	110
60530	75,00	110
60531	70,00	110
60532	60,00	110
60533	75,00	111-190
60534	91,00	111-196
60535	53,00	105
60536	61,00	105
60537	69,00	105
60538	63,00	105
60539	71,00	105
60540	79,00	105
60541	53,00	106
60542	61,00	106
60543	69,00	106
60544	85,00	106
60545	75,00	106
60546	70,00	106
60547	60,00	106
60548	75,00	107-190
60549	91,00	107-196
60558	12,00	297
60559	1,90	307
60563	97,00	251
60564	50,00	253
60565	43,00	255
60566	68,00	257
60567	37,00	261
60592	81,00	116-191
60594	81,00	107-190
60686	5,50	302
60687	5,50	302
60690	148,00	228
60691	121,00	228
60694	295,00	244
60696	23,00	272
60697	35,00	272
60698	26,00	272
60701	16,00	297
60702	16,00	297
60704	144,00	55
60705	144,00	55
60706	188,00	55
60707	188,00	55
60708	21,00	298
60709	21,00	298
60710	11,00	302
60712	95,00	93
60713	95,00	93
60714	15,00	299
60715	15,00	299
60716	63,00	130
60717	71,00	130
60718	79,00	130
60725	87,00	133-198
60726	87,00	124-197
60727	87,00	128-198
60729	320,00	162
60731	207,00	163-167
60732	17,00	301
60733	21,00	298

Ref.	€	Pág.
60734	58,00	265
60735	45,00	265
60736	48,00	265
60737	21,00	301
60738	21,00	301
60739	330,00	266
60740	290,00	266
60741	105,00	268
60742	69,00	269
60745	227,00	217
60746	98,00	212
60747	124,00	214
60748	175,00	216
60761	352,00	45-278
60791	592,00	48-284
90011	4,35	235
90025	6,00	302
90026	6,00	302
90027	6,00	302
90703	7,00	236
90704	9,00	236
90755	23,00	296
90758	19,00	234
90760	10,00	300
90761	10,00	300
90763	21,00	300
90770	11,00	300
90794	18,00	304
90796	13,00	234
92049	65,00	76-187
92075	45,00	138-200
92350	75,00	120-192
92351	81,00	120-192
92603	131,00	72-184
92801	45,00	264
92901	5,50	298
93510	121,00	70
93511	121,00	71
93512	266,00	71
93513	214,00	71
93528	73,00	325
93529	73,00	325
93530	135,00	325
93531	102,00	325
94458	8,50	301
94459	8,50	301
94474	72,00	74
94475	72,00	76
94476	126,00	75
94477	81,00	75
94489	27,00	75
94600	12,00	298
94694	61,00	118-274
94695	53,00	118
94696	53,00	119
94697	85,00	119
94698	70,00	119
95012	9,50	299
95040	2,75	305
95042	7,50	306
95043	4,00	305
95044	2,25	306
95045	2,25	306
95046	2,25	306
95051	13,00	306
95052	9,50	300
95110	9,50	299
95126	21,00	298
95132	21,00	298
95133	21,00	298

Ref.	€	Pág.
95158	21,00	298
95163	21,00	298
95164	21,00	298
95165	21,00	298
95167	21,00	298
95168	21,00	298
95169	21,00	298
95174	9,50	299
95175	9,50	299
95178	21,00	298
95181	13,00	299
95182	13,00	299
95183	13,00	298
95184	13,00	298
95185	13,00	298
95186	13,00	298
95187	13,00	298
95190	13,00	299
95191	13,00	299
95192	13,00	299
95193	13,00	298
95194	13,00	299
95195	9,50	299
95196	9,50	299
95222	9,50	299
95223	9,50	299
95224	9,50	299
95225	9,50	299
95226	13,00	299
95227	13,00	299
95228	13,00	299
95229	13,00	299
95230	9,50	299
95231	9,50	299
95232	9,50	299
95233	9,50	299
95234	13,00	299
95235	13,00	299
95236	13,00	299
95237	13,00	299
95242	13,00	298
95243	13,00	298
95244	21,00	298
95245	21,00	298
95246	21,00	298
95247	21,00	298
95248	21,00	298
95249	21,00	298
95250	13,00	298
95251	13,00	298
95540	97,00	310
95663	22,00	313
95664	57,00	314
95665	54,00	314
95666	54,00	314
95667	538,00	313
95668	33,00	313
95669	33,00	313
95670	43,00	313
95671	72,00	314
95717	33,00	310
95749	38,00	313
95753	181,00	311
95754	67,00	311
95755	78,00	311
95756	41,00	313
95806	54,00	314
95821	186,00	310
95824	54,00	313
95828	93,00	313

Ref.	€	Pág.
95829	54,00	314
95832	93,00	313
95837	52,00	313
95838	93,00	313
95839	41,00	313
95840	43,00	313
96028	154,00	321
96066	118,00	119
96067	91,00	121-196
96084	59,00	136
96085	59,00	137
96086	87,00	137
96087	61,00	137
96088	50,00	138-200
96089	59,00	138-200
96090	143,00	325
96095	124,00	167
96097	27,00	137-273
96114	17,00	225
96117	14,00	203
96118	191,00	307
96120	40,00	306
96122	15,00	236
96127	55,00	264
96128	42,00	264
96133	17,00	273
96134	32,00	273
96136	25,00	271
96141	26,00	225
96152	66,00	264
96153	41,00	225
96154	455,00	77-290
96161	20,00	301
96164	20,00	301
96173	52,00	296
96174	43,00	296
96199	10,00	300
96200	6,00	302
96201	7,00	303
96202	5,00	302
96205	10,00	300
96208	8,50	301
96213	16,00	300
96217	16,00	300
96223	13,00	298
96232	7,50	299
96233	7,50	299
96234	3,75	299
96238	6,00	305
96243	2,75	305
96254	18,00	297
96255	18,00	297
96256	15,00	299
96264	21,00	235
96267	6,50	305
96273	93,00	304
96292	43,00	307
96299	9,50	307
96340	51,00	326
96341	51,00	326
96342	82,00	326
96343	70,00	326
96344	72,00	327
96345	78,00	327
96346	88,00	327
96365	538,00	169
96413	8,00	235
96436	1113,00	67-286
96437	87,00	223
96458	12,00	235

ÍNDICE REFERENCIAS

Ref.	€	Pág.
96462	31,00	139-201
96464	11,00	203
96468	111,00	70
96490	345,00	31-278
96511	129,00	70
96512	129,00	71
96537	81,00	325
96538	81,00	325
96541	61,00	118
96542	61,00	119
96543	59,00	326
96544	59,00	326
96545	80,00	74
96546	80,00	76
96547	67,00	136
96548	67,00	137
96561	137,00	70
96562	137,00	71
96746	576,00	76-285
96747	500,00	77-290
96749	299,00	323
96754	31,00	139-201
96755	255,00	331
96767	31,00	139-201
96771	410,00	331
96776	243,00	322
96777	182,00	322
96778	283,00	322
96779	209,00	322
96786	22,00	234
96942	8,50	235
97001	152,00	78
97002	152,00	79
97003	243,00	79
97004	155,00	324
97005	152,00	79-187
97006	232,00	78
97007	232,00	79
97012	369,00	324
97013	316,00	324
97018	1113,00	80-286
97020	702,00	80
97041	243,00	28
97042	243,00	28
97043	243,00	30
97044	394,00	30
97045	348,00	30
97046	233,00	31-179
97053	290,00	29
97054	259,00	29
97055	985,00	32-288
97056	936,00	32-288
97057	1182,00	33-284
97058	1017,00	33-284
97059	259,00	29
97060	430,00	31
97061	142,00	64
97062	142,00	65
97064	149,00	323
97065	188,00	64
97069	199,00	66-186
97076	217,00	65
97086	168,00	66-183
97101	538,00	169
97104	47,00	165
97106	17,00	296
97107	17,00	296
97112	28,00	235
97113	19,00	235
97114	16,00	236

Ref.	€	Pág.
97125	168,00	78
97126	168,00	79
97127	248,00	78
97131	259,00	28
97132	259,00	28
97133	259,00	30
97134	306,00	29
97135	158,00	64
97136	158,00	65
97142	16,00	234
97148	26,00	237
97276	254,00	222
97363	1,25	307
97364	31,00	304
97368	41,00	230
97369	14,00	300
97370	14,00	300
97371	14,00	300
97372	14,00	300
97395	18,00	297
97396	3,75	236
97397	6,00	236
97399	7,00	306
97403	245,00	320
97404	202,00	320
97410	190,00	320
97411	194,00	320
97417	1030,00	321
97419	1100,00	321
97474	19,00	300
97670	9,50	236
97688	2,25	305
97689	5,00	302
97697	8,50	301
97698	8,50	301
97699	8,50	301
97740	28,00	271
97800	86,00	270
97801	114,00	270
97802	64,00	270
97803	59,00	270
97804	219,00	72-186
97805	87,00	121-197
97806	189,00	165
97809	17,00	271
97810	243,00	24
97811	295,00	24
97812	243,00	25
97813	394,00	25
97814	348,00	25
97815	295,00	25-178
97816	6,50	236
97817	19,00	300
97822	9,50	299
97823	9,50	299
97824	17,00	300
97825	3,75	305
97827	5,50	301
97828	5,50	301
97829	75,00	301
97840	251,00	24
97841	259,00	24
97842	303,00	24
97843	311,00	24
97844	251,00	25
97845	259,00	25
97846	363,00	25
97847	317,00	25
97850	251,00	28
97851	251,00	30

Ref.	€	Pág.
97852	251,00	28
97853	363,00	30
97854	317,00	30
97855	298,00	29
97862	215,00	320
97863	172,00	320
97866	150,00	64
97868	150,00	65
97870	128,00	323
97881	160,00	78
97882	160,00	79
97883	222,00	79
97884	134,00	324
97885	240,00	78
97899	245,00	71
97900	193,00	71
97915	89,00	325
97916	89,00	325
97917	115,00	325
97918	82,00	325
97927	88,00	74
97928	88,00	76
97929	105,00	75
97930	60,00	75
97931	75,00	136
97932	75,00	137
97933	77,00	137
97934	51,00	137
97935	69,00	118
97936	69,00	119
97939	67,00	326
97940	67,00	326
97956	690,00	320
97973	59,00	138-200
97974	45,00	138-200
97975	95,00	121-203-274
97983	21,00	233
97984	25,00	231
97985	71,00	227
97986	83,00	227
97987	71,00	227
97988	89,00	226
97989	48,00	229
97990	55,00	229
97991	46,00	229
97992	59,00	229
97994	27,00	231
97996	16,00	225
97997	226,00	31
97998	166,00	31
97999	64,00	230
98000	66,00	225
98001	26,00	237
98004	35,00	230
98005	21,00	225
98006	11,00	203
98008	19,00	300
98009	295,00	26
98010	243,00	26
98011	243,00	27
98012	394,00	27
98013	348,00	27
98014	270,00	27-179
98017	251,00	26
98018	259,00	26
98019	251,00	27
98020	259,00	27
98022	36,00	236
98027	52,00	301
98102	131,00	62

ÍNDICE REFERENCIAS

Ref.	€	Pág.
98103	175,00	62
98104	131,00	63
98105	179,00	63
98106	148,00	63
98107	166,00	63-183
98109	147,00	62
98110	139,00	62
98111	191,00	62
98112	183,00	62
98113	147,00	63
98114	139,00	63
98137	59,00	328
98138	67,00	328
98139	59,00	328
98140	67,00	328
98141	51,00	328
98142	51,00	328
98143	82,00	328
98144	70,00	328
98145	69,00	329
98146	84,00	329
98149	169,00	142-279
98150	363,00	27
98151	317,00	27
98153	314,00	31-278
98158	348,00	324
98159	295,00	324
98160	278,00	323
98165	85,00	88
98166	83,00	89
98167	117,00	89
98168	94,00	89
98169	125,00	90-188
98170	93,00	88
98171	101,00	88
98172	91,00	89
98173	99,00	89
98175	87,00	84
98176	85,00	85
98177	150,00	85
98178	119,00	85
98179	158,00	86-188
98180	164,00	86-195
98181	95,00	84
98182	103,00	84
98183	93,00	85
98184	101,00	85
98185	126,00	68
98186	173,00	68
98187	126,00	69
98188	194,00	69
98189	162,00	69
98190	155,00	69-184
98191	134,00	68
98192	142,00	68
98193	181,00	68
98194	189,00	68
98195	134,00	69
98196	142,00	69
98197	147,00	38
98198	147,00	39
98199	220,00	39
98200	174,00	39
98201	177,00	39-180
98202	155,00	38
98203	163,00	38
98204	155,00	39
98205	163,00	39
98206	13,00	299
98208	5,50	235

Ref.	€	Pág.
98209	13,00	299
98210	13,00	299
98212	13,00	298
98213	13,00	298
98215	21,00	298
98216	21,00	298
98235	27,00	237
98236	27,00	237
98237	10,00	300
98238	10,00	300
98239	19,00	300
98240	13,00	298
98241	13,00	298
98242	13,00	298
98267	14,00	300
98280	102,00	89
98281	79,00	89
98282	135,00	85
98283	104,00	85
98320	20,00	295
98321	20,00	295
98322	33,00	295
98323	41,00	295
98324	160,00	294
98325	342,00	294
98326	40,00	294
98329	94,00	132-198
98330	53,00	130
98331	53,00	131
98332	85,00	131
98333	70,00	131
98334	75,00	132-193
98335	91,00	133-198
98336	61,00	130
98337	69,00	130
98338	61,00	131
98339	69,00	131
98340	75,00	131
98341	60,00	131
98342	7,90	234
98343	3,31	235
98344	81,00	132-193
98354	52,00	136
98355	60,00	136
98356	68,00	136
98413	217,00	38
98415	690,00	40-288
98416	149,00	40
98417	109,00	40
98423	182,00	85
98426	184,00	74
98427	192,00	74
98428	200,00	74
98429	151,00	75
98440	104,00	230
98441	104,00	230
98442	52,00	271
98444	185,00	322
98446	269,00	29
98447	420,00	30
98448	60,00	273
98449	27,00	134-273
98450	32,00	134-199
98451	28,00	273
98455	75,00	120
98456	116,00	120
98458	27,00	121-273
98459	32,00	121-199
98470	149,00	323
98478	184,00	142-279

Ref.	€	Pág.
98490	11,00	300
98491	16,00	300
98492	28,00	302
98493	32,00	302
98497	16,00	305
98498	277,00	29
98499	285,00	29
98500	91,00	121-197
98501	32,00	134-199
98517	191,00	307
98518	44,00	224
98527	320,00	243-289
98539	189,00	39
98540	143,00	39
98541	158,00	63
98542	127,00	63
98543	173,00	69
98544	141,00	69
98549	94,00	90-195
98552	126,00	90-195
98601	5,00	302
98610	73,00	100
98611	69,00	101
98612	120,00	101
98613	98,00	101
98614	102,00	102-190
98615	92,00	102-189
98616	81,00	100
98617	89,00	100
98618	77,00	101
98619	85,00	101
98630	14,00	300
98631	13,00	298
98632	13,00	298
98640	466,00	145-285
98645	105,00	101
98646	83,00	101
98647	39,00	306
98650	14,00	258
98651	30,00	258
98652	35,00	258
98653	38,00	258
98654	87,00	258
98655	25,00	254
98656	36,00	254
98657	34,00	254
98658	53,00	254
98659	128,00	254
98666	2,75	305
98667	2,75	305
98671	595,00	240-286
98672	44,00	224
98673	14,00	297
98674	15,00	297
98675	18,00	297
98678	172,00	53
98679	140,00	53
98680	140,00	52
98681	140,00	53
98682	193,00	53
98683	161,00	53
98684	169,00	53-182
98685	148,00	52
98686	156,00	52
98687	148,00	53
98688	156,00	53
98689	197,00	60-186
98690	111,00	58
98691	111,00	59
98692	158,00	59

ÍNDICE REFERENCIAS

Ref.	€	Pág.
98693	127,00	59
98694	166,00	60-183
98695	119,00	58
98696	127,00	58
98697	119,00	59
98698	127,00	59
98699	137,00	59
98700	106,00	59
98703	124,00	210
98706	141,00	210
98707	141,00	210
98708	141,00	210
98709	141,00	210
98710	141,00	210
98711	82,00	212-214
98714	98,00	212
98715	98,00	213
98716	98,00	212
98717	98,00	213
98718	98,00	213
98719	98,00	213
98720	98,00	212
98721	98,00	212
98723	98,00	213
98724	93,00	213
98725	93,00	213
98729	124,00	214
98730	124,00	215
98731	124,00	214
98732	124,00	215
98733	124,00	215
98734	124,00	215
98735	124,00	214
98736	124,00	215
98738	124,00	215
98739	110,00	215
98740	110,00	215
98742	113,00	216
98745	175,00	216
98746	175,00	216
98747	175,00	216
98748	175,00	216
98749	175,00	216
98750	227,00	217
98751	3,75	306
98752	3,75	306
98757	305,00	173
98758	21,00	298
98759	31,00	304
98760	207,00	165
98761	390,00	330
98763	174,00	143-278
98764	290,00	173
98766	88,00	329
98767	72,00	329
98774	6,00	302
98775	9,50	302
98776	19,00	301
98781	16,00	300
98783	183,00	52
98784	152,00	58
98785	389,00	30
98786	2,50	303
98787	5,00	303
98788	6,50	303
98789	6,50	303
98791	6,50	303
98792	6,50	303
98793	4,75	303
98794	4,75	303

Ref.	€	Pág.
98795	4,75	303
98796	2,50	303
98797	2,50	303
98798	34,00	271
98799	36,00	271
98800	59,00	130
98803	79,00	132-193
98804	85,00	132-193
98805	67,00	130
98806	75,00	130
98817	75,00	119
98818	60,00	119
98822	203,00	141-279
98823	218,00	142-279
98824	33,00	254
98825	27,00	258
98826	48,00	259
98827	43,00	259
98850	499,00	242-290
98866	14,00	300
98867	14,00	300
98868	14,00	300
98869	14,00	300
98870	13,00	300
98871	17,00	300
98872	18,00	300
98880	23,00	236
98881	22,00	246
98884	18,00	233
98885	18,00	246
98886	64,00	247
98888	26,00	233
98892	139,00	224
98895	67,00	261
98896	45,00	261
98897	50,00	261
98899	99,00	222
98902	17,00	300
98903	17,00	300
98909	340,00	135
98910	85,00	84
98911	93,00	84
98912	101,00	84
98913	153,00	86-188
98914	83,00	88
98915	91,00	88
98916	99,00	88
98917	123,00	90-188
98918	71,00	100
98919	79,00	100
98920	87,00	100
98921	88,00	102-189
98922	100,00	102-190
98924	30,00	330
98926	7,00	302
98927	7,00	302
98928	188,00	141-279
98929	203,00	142-279
98986	2,75	305
98992	32,00	134-199
98996	124,00	307
98997	15,00	235
98998	13,00	305
99108	155,00	60-183
99127	15,00	298
99128	10,00	236
99129	14,00	234
99130	8,50	298
99136	223,00	247
99142	289,00	243-290

Ref.	€	Pág.
99145	83,00	84
99146	91,00	84
99147	99,00	84
99149	81,00	88
99150	89,00	88
99151	97,00	88
99153	69,00	100
99154	77,00	100
99155	85,00	100
99161	57,00	130
99162	65,00	130
99163	73,00	130
99172	40,00	307
99173	16,00	203
99174	31,00	304
99185	95,00	84
99186	97,00	84
99187	99,00	84
99188	103,00	84
99189	105,00	84
99190	107,00	84
99191	111,00	84
99192	113,00	84
99193	115,00	84
99195	89,00	88
99196	91,00	88
99197	93,00	88
99198	97,00	88
99199	99,00	88
99200	101,00	88
99201	105,00	88
99202	107,00	88
99203	109,00	88
99205	80,00	100
99206	82,00	100
99207	84,00	100
99208	88,00	100
99209	90,00	100
99210	92,00	100
99211	96,00	100
99212	98,00	100
99213	100,00	100
99214	61,00	131-275
99215	85,00	133-202-275
99216	99,00	133-203-275
99217	15,00	298
99221	67,00	132-194
99222	69,00	132-194
99223	71,00	132-194
99224	9,50	299
99225	9,50	299
99226	13,00	300
99227	16,00	300
99228	17,00	300
99230	6,00	302
99231	6,00	302
99233	6,00	302
99242	55,00	126
99243	63,00	126
99244	71,00	126
99245	65,00	126
99246	73,00	126
99247	81,00	126
99248	57,00	126
99249	65,00	126
99250	73,00	126
99251	67,00	126
99252	75,00	126
99253	83,00	126
99265	79,00	128-192

ÍNDICE REFERENCIAS

Ref.	€	Pág.
99308	309,00	135
99317	55,00	122
99318	63,00	122
99319	71,00	122
99320	65,00	122
99321	73,00	122
99322	81,00	122
99323	57,00	122
99324	65,00	122
99325	73,00	122
99326	67,00	122
99327	75,00	122
99328	83,00	122
99340	79,00	124-192
99386	87,00	94-194
99388	91,00	94-194
99389	96,00	94-195
99392	34,00	95-273
99393	27,00	95-273
99410	267,00	34
99411	275,00	34
99412	283,00	34
99413	202,00	34
99414	210,00	34
99415	218,00	34
99416	202,00	35
99417	210,00	35
99418	218,00	35
99419	347,00	35
99420	316,00	35
99421	257,00	35
99422	226,00	35
99423	210,00	35-179
99424	21,00	298
99425	21,00	298
99426	21,00	298
99427	21,00	298
99428	274,00	22
99429	282,00	22
99430	290,00	22
99431	274,00	22
99432	282,00	22
99433	290,00	22
99434	419,00	22
99435	388,00	22
99436	373,00	22
99437	342,00	22
99438	347,00	23-178
99439	916,00	22
99440	183,00	176
99441	199,00	176
99442	263,00	176
99443	231,00	174
99444	317,00	168
99445	355,00	168
99446	21,00	298
99447	21,00	298
99450	95,00	246
99451	20,00	252
99453	34,00	252
99454	37,00	252
99455	34,00	252
99456	65,00	253
99457	93,00	253
99458	166,00	253
99459	23,00	256
99460	34,00	256
99461	33,00	256
99462	47,00	256
99463	43,00	256

Ref.	€	Pág.
99464	32,00	256
99465	35,00	257
99466	55,00	257
99467	86,00	257
99468	128,00	257
99469	109,00	259
99470	19,00	250
99471	48,00	250
99472	64,00	250
99473	46,00	250
99474	42,00	250
99475	54,00	250
99476	39,00	251
99477	81,00	251
99478	101,00	251
99479	166,00	251
99480	102,00	259
99481	23,00	260
99482	28,00	260
99483	33,00	260
99484	38,00	260
99540	13,00	300
99541	16,00	300
99542	17,00	300
99543	17,00	300
99600	65,00	222
99601	225,00	222
99602	139,00	222
99603	65,00	222
99604	25,00	223
99606	39,00	223
99607	35,00	224
99608	44,00	224
99609	16,00	234
99610	31,00	233
99611	18,00	234
99612	24,00	234
99613	27,00	233
99614	16,00	234
99615	17,00	233
99616	86,00	230
99617	86,00	230
99618	41,00	229
99619	43,00	229
99620	68,00	228
99621	42,00	228
99622	55,00	228
99623	224,00	227
99624	64,00	226
99625	69,00	226
99626	88,00	226
99627	83,00	226
99628	89,00	226
99646	373,00	95-288
99652	57,00	301
99656	17,00	300
99657	31,00	304
99658	31,00	304
99659	21,00	298
99660	28,00	302
99661	23,00	302
99664	19,00	300
99665	17,00	300
99667	17,00	300
99668	17,00	300
99669	17,00	300
99670	17,00	300
99671	17,00	300
99672	17,00	300
99673	17,00	300

Ref.	€	Pág.
99674	17,00	300
99684	189,00	165
99685	166,00	223
99686	157,00	223
99687	142,00	223
99688	225,00	222
99689	225,00	222
99690	90,00	222
99691	120,00	222
99692	90,00	222
99693	120,00	222
99708	351,00	23-178
99715	214,00	35-179
99718	216,00	210
99719	135,00	212
99720	156,00	214
99727	373,00	98-289
99731	595,00	45-284
99732	518,00	44-289
99733	254,00	174
99735	212,00	174
99736	57,00	301
99737	16,00	302
99799	72,00	326
99800	57,00	326
99801	72,00	328
99802	57,00	328
99817	13,00	300
99820	53,00	126
99821	61,00	126
99822	69,00	126
99823	63,00	126
99824	71,00	126
99825	79,00	126
99826	53,00	127
99827	61,00	127
99828	69,00	127
99829	85,00	127
99830	75,00	127
99831	70,00	127
99832	60,00	127
99833	75,00	128-192
99834	91,00	128-198
99835	53,00	122
99836	61,00	122
99837	69,00	122
99838	63,00	122
99839	71,00	122
99840	79,00	122
99841	53,00	123
99842	61,00	123
99843	69,00	123
99844	85,00	123
99845	75,00	123
99846	70,00	123
99847	60,00	123
99848	75,00	124-192
99849	91,00	124-197
99850	145,00	177
99851	145,00	177
99852	21,00	298
99853	7,00	302
99862	2,75	305
99928	110,00	97
99929	118,00	97
99930	126,00	97
99931	110,00	93
99932	118,00	93
99933	126,00	93
99944	87,00	86-194

Ref.	€	Pág.
99945	91,00	86-194
C75191	79,00	157
C75236	3462,00	155
C75238	81,00	155
C75239	82,00	155
C75245	46,00	155
C75270	395,00	151
C75271	564,00	151
C75272	427,00	151
C75273	29,00	151
C75274	29,00	151
C75275	55,00	151

Condiciones de venta

Sales conditions
Conditions de vente

Condiciones Generales de Venta

1. Generalidades

Las ventas del GRUPO STH, compuesto por Standard Hidráulica, Hidrostandard del Mediterráneo y Comap Ibérica, se regirán por las presentes Condiciones Generales de Venta, excepto en todo aquello que esté expresamente acordado de forma distinta en la confirmación de pedido u oferta.

2. Precios

Los precios incluidos en la tarifa se expresan en € (impuestos no incluidos). Pedido mínimo: 200€, excepto en Clever, que no hay pedido mínimo.

Política de portes: El importe de pedido para PORTES PAGADOS será a determinar en función de las condiciones particulares de cada país y cliente.

Dentro del territorio de España, Andorra y Portugal, los pedidos cuyo importe neto sea superior a 350 € para los catálogos de Fontanería y Calefacción, Canalización y Control del Agua, Regulación y Conducción de Gas, y, Bricostandard, o 200 € para Clever, viajarán a PORTES PAGADOS. Por debajo de este importe se cargará un importe fijo en factura de 7 €, o si lo prefieren, a portes debidos.

Para pedidos de tuberías en barras o placas para suelo radiante, el importe neto para PORTES PAGADOS será de 1.000€. Por debajo de este importe se cargará un importe fijo en factura de 50€, o si lo prefieren, a portes debidos.

Para pedidos con productos de fundición, el importe neto para PORTES PAGADOS será de 600€. Por debajo de este importe se cargará un importe fijo en factura de 25€, o si lo prefieren, a portes debidos.

Quedan excluidas las Islas Canarias, Ceuta, Melilla, Azores y Madeira donde el pedido mínimo para PORTES PAGADOS será de 900 €. Por debajo de este importe se cargará los gastos de transporte en factura según tarifa de agencia. Todos los precios y costes mencionados con anterioridad, así como cualquiera de los costes asociados, no incluyen el correspondiente IVA que deberá añadirse, al tipo que especifique la legislación en vigor.

El GRUPO STH se reserva el derecho de modificar los precios de la tarifa en vigor en cualquier momento sin necesidad de preaviso. Los precios aplicables serán los vigentes en el momento en que se realice el pedido.

En caso de envío de muestras, estas serán a cargo del cliente, a quien se abonarán siempre que el proyecto para las que se han enviado se materialice en un pedido.

3. Plazo de entrega y descarga de la mercancía

Los pedidos que se reciban sin indicación de fecha de entrega se servirán en el plazo más breve de tiempo.

Las fechas de envío que aparecen en la confirmación del pedido son orientativas.

Las entregas anticipadas y los envíos parciales estarán autorizados si no existe un acuerdo por escrito que lo prohíba.

La incapacidad de efectuar o servir un pedido por motivos de huelga, fracaso de la negociación, cierre de negocio y consecuencias derivadas de los mismos serán consideradas como de fuerza mayor y eximen a GRUPO STH de su obligación de servir la mercancía y, el cliente no podrá reclamar en modo alguno daños y perjuicios.

En el caso de aplazamiento de pago de las facturas pendientes, así como de su impago, y/o por exceder el cliente el límite de crédito que GRUPO STH tenga asegurado, los pedidos pendientes de servir quedarán retenidos hasta la resolución de la incidencia en cuestión.

4. Facturación

El grupo STH se reserva el derecho de enviar y facturar los pedidos del cliente por cualquiera de las empresas del grupo, dependiendo de la situación crediticia del cliente.

Los datos de la empresa proveedora, se detallarán en el albarán de venta, no aceptándose ninguna modificación tras el envío.

GRUPO STH trabaja con facturación electrónica.

5. Condiciones de Pago

La financiación máxima nunca excederá de los parámetros contemplados en la Ley 15/2010 por la que se establecen medidas de lucha contra la morosidad en las operaciones comerciales.

La falta de pago a un vencimiento de cualquier factura conllevará la inmediata suspensión del suministro de materiales.

En caso de que el GRUPO STH conceda al Cliente un aplazamiento en el pago de una factura más allá de la fecha de vencimiento inicialmente pactada, se aplicará una penalización de un 3% mensual.

En caso de impago, dicha penalización será del 5% mensual, con un mínimo de 15 €, al que se le añadirá un 3% mensual a partir del 2º mes de demora.

Independientemente del concepto que el cliente de a un pago, los pagos que se efectúen se imputarán en primer lugar a las penalizaciones por aplazamiento y/o impago, y a continuación al principal de las deudas que tengan un vencimiento más antiguo.

Todas las operaciones comerciales están aseguradas por una entidad de seguro de crédito.

6. Devolución de mercancía

Todas las solicitudes de devolución deberán ser analizadas y aceptadas por el GRUPO STH, debiendo informar el cliente de los motivos, justificando la fecha de compra con la factura.

Las devoluciones ocasionadas por errores de entrega, ya sea por defectos de identidad y/o cantidad deberán ser gestionadas durante los 7 días posteriores a la entrega de material.

El resto de solicitudes de devolución se analizarán en base a los criterios marcados por el grupo STH. No se aceptará ningún material que esté descatálogo o fuera de garantía. Se aplicará un demérito a las devoluciones aceptadas, que podrá ir del 15% al 50% según el año de compra y siempre que se encuentre en perfecto estado para su venta. Los portes serán a cargo del cliente.

7. Reclamaciones, garantía y compensación

De conformidad con lo establecido en la legislación vigente, la reclamación por daños o averías de las mercancías transportadas así como las diferencias de cantidad recibidas, deberán notificarse en las 24 horas siguientes a la recepción conforme de las mismas salvo que el daño fuera evidente en el momento de la recepción de las mercancías. Después de dichas 24 horas, las reclamaciones serán consideradas fuera de plazo, siendo desestimadas.

La garantía que se aplicará sobre los productos del GRUPO STH será de un mínimo de 2 años y de 5 años para la grifería.

Los cartuchos termostáticos, temporizados y mecanismos electrónicos tienen una garantía de 2 años.

Los accesorios (flexos, teléfonos de ducha, rociadores, soportes, barras de ducha, etc.) tienen una garantía de 2 años.

La fecha de adquisición debe justificarse adecuadamente mediante la correspondiente factura de compra. Para que la garantía sea válida, es necesaria la aceptación del defecto por parte del departamento técnico.

Quedan excluidos de la garantía los daños producidos por la instalación, mantenimiento y limpieza no realizada de acuerdo con las instrucciones de montaje, así como su uso inadecuado y desgaste natural.

La garantía cubre la reposición del material sin cargo, limitando nuestra responsabilidad a la sustitución o reparación de las piezas defectuosas reconocidas por el GRUPO STH, sin indemnización alguna. En caso de que el producto ya no se fabrique, se suministrará un producto similar de igual calidad.

Nos reservamos el derecho de modificar el diseño de nuestros productos sin previo aviso.

8. Responsabilidad Civil derivada del producto

El GRUPO STH sólo será responsable de los daños derivados de defectos originales de calidad internos de los productos.

El GRUPO STH nunca será responsable de los daños derivados de defectos de calidad aparentes de los productos que pudieron ser detectados por el cliente antes de su reventa o montaje en cualquier obra y/o instalación, así como de los daños derivados de una mala instalación y/o manipulación por incumplimiento de las condiciones de montaje, puesta en funcionamiento y utilización (por ejemplo, las instrucciones de uso) o de las condiciones administrativas establecidas.

Las limitaciones de responsabilidad serán aplicadas completamente a los sucesivos compradores, con la obligación de ser adoptadas por todos los futuros compradores. Se establece como límite máximo de la responsabilidad civil que asumirá GRUPO STH derivada de daños causados por los productos, un importe de 2.000 €.

9. Daños a destinatarios

En el caso de que el cliente tenga conocimiento de que se hayan producido daños que pudiesen ser derivados por instalaciones hechas con los productos y sistemas del GRUPO STH (especialmente en caso de reclamación formal o legal de dicho destinatario al cliente), deberá notificarlo de forma urgentísima y por escrito al GRUPO STH y facilitarle la comprobación, valoración y causas de los daños para poder determinar las causas y responsabilidades.

El GRUPO STH en ningún caso responderá a ninguna reclamación de daños provenientes de los productos (ya sean acciones directas o de repetición) si no ha tenido la ocasión de poder valorar y comprobar la realidad de los daños y sus posibles causas.

10. Jurisdicción y Derecho aplicable

Respecto a todos los litigios que surgieran en el marco de la relación contractual entre GRUPO STH y el cliente serán competentes los Juzgados y Tribunales de Barcelona. Asimismo, se acuerda como Derecho aplicable el Derecho Español.

11. Validez

Estas condiciones de venta anulan las anteriores y estarán vigentes hasta cualquier cambio publicado en www.standardhidraulica.com.

Sales conditions**1.General**

Sales done by STH GROUP (Standard Hidraulica, S.A.U., Hidrostandard del Mediterráneo, S.A.U. and Comap Ibérica), will be regulated by these sales conditions, except for those which are agreed on the offer or order confirmation.

2.Prices

All prices in the catalogue are in Euros, and these are exclusive of VAT which will, if applicable, be added to the invoice at the current rate.

STH Group consider acceptable a minimum order of 200euros, except for Clever that there is no minimum order.

The Order amount for having the transport paid, it will be depending on the country and the customer.

When we talk about the samples these will be always invoiced and afterwards when we get the Project, we will issue the credit note.

3.Delivery of the goods

Orders with no specific delivery time, will be dispatched as soon as possible.

The delivery dates appearing on the order confirmation are only estimates, advanced deliveries and partial dispatches will be authorized if there is no written agreement that forbids them.

Any incapacity to effect or supplies an order for reasons such as: strike, breakdown of the negotiations, close the business and all their consequences will be considered a majeure force and release STH Group from his obligation to supply the goods and the customer may not make any claim for damages.

In the case of postponing the payment of the outstanding invoices, as well as unsettle them and exceed the limit of the assured credit, the outstanding orders will be kept in our warehouse until the incident is solved.

STH Group will be the owner of the goods until the invoice is settled in full.

4.Invoices

All the commercial deals are insured by an Insurance Company. STH Group reserves the right to invoice the customer by any company from the Group depending the Insurance amount the client has. The company's details will be informed in the delivery note, without any possible change once we send it. STH Group works with electronic invoicing.

5.Payment conditions

Maximum payment terms will never exceed the factors fixed in the law 15/2010.

To unpaid an invoice on its due date it will force to stop the deliveries of other shipments.

The payment conditions in the invoice will be considered as unconditional: every change must be agreed in advanced

The Company reserves the right to charge interest at a rate up to 3% monthly, and the non-payment will be charged up to 5%, with a minimum amount of 15 €, and 3% will be added each month from the second month of the delay.

It does not matter the payment subject, once STH Group receives the payment always it will be deduced first the penalties.

If the payment is not insured, STH Group will agree with the client the payment terms.

6.Returned goods and dispatch

All the devolutions must be analysed and accepted by STH Group, previously being informed by the customer about the inconveniences and the invoice number.

The returns caused due to delivery mistakes, like identity errors or/and quantity discrepancies, should be managed the following 7 days after its delivery.

The goods which have been returned for different reasons that the ones mentioned before, will be charged with a demerit (from the 15% until the 50%), and the transport costs will be paid by the customer.

The products which are discontinued and are out of guarantee will not be accepted.

7.Claims, warranty and compensation

Any fault or anomaly, including a shortfall in the assured quality of the product, must be reported in writing within the following 24hours after its reception unless the problem cannot be seen easily.

The guarantee that will be applied to the products of the STH Group will be 2 years and 5 years for the mixers, except for:

- Thermostatic cartridges, delay actions and electronic mechanisms will have 2 years guarantee.

- Accessories will also have 2 years guarantee (hose bibs, hand showers, rain showers, holders, sliding bars...)

To all effects, the guarantee will start from the invoice date on. It will be excluded from the guarantee all the products damaged on their installation, maintenance and cleaning which is not done according the rules and its unappropriated use.

The guarantee covers to replace or repair the goods, if these are discontinued will be substitute them for similar ones.

We reserve the right to modify any product design without informing previously.

8. Civil Liability

Outside the application of the product liability's laws, the Company will only be responsible for damage, if according to legal resolutions, serious blame is proved.

The Company will not reply and there will be no claim for damages in the case of non-fulfilment of assembly conditions, come into operation and use (such as in the instructions of use) or in the established administrative conditions. The limitations of responsibility will be applied in full on successive purchasers and must be adopted by all future ones.

Once the customer knows the damage caused by one faulty product, he must inform immediately STH Group in a writing way and add all the necessary information to show causes and possible responsibilities for STH Group defence.

The maximum limit of liability which will be paid by STH Group derived from a faulty product will be 2.000€

9. Consignee damages

In the case that STH Group products cause damages on an installation (especially when it is officially demanded by the customer), it should be informed urgently in a written way to STH Group, and send the verification, the estimation of damages and its causes.

10. Jurisdiction and applicable Law

With respect to all lawsuits that might arise within the framework between the Company and the customer contractual relationship, the Courts and Tribunals of Barcelona will hold all competence. Likewise, it is agreed that the applicable Law will be Spanish Law.

11. Validity.

These Sales Conditions cancel the previous ones and they will be valid till any modification is published in our website www.standardhidraulica.com

CONDITIONS GÉNÉRALES DE VENTE

Conditions générales de vente

1. Généralités

Les ventes effectuées par le Groupe STH, composé des sociétés Standard Hidráulica, Hidrostandard del Mediterráneo et Comap Ibérica, seront assujetties aux présentes Conditions générales de vente, à l'exception des cas particuliers accordés expressément sur l'offre ou la confirmation de commande.

2. Prix

Les prix figurant dans notre tarif sont exprimés en €, hors taxes, et en conditions Ex Works Montcada i Reixac. Le montant minimum des commandes pour obtention du Franco de Port sera déterminé en fonction des conditions particulières de chaque pays et client.

Le Groupe STH se réserve le droit de modifier les prix du tarif en vigueur, sans délai d'avis préalable. Les prix appliqués seront ceux de la date de réception de la commande. Les frais d'envoi d'échantillons seront à la charge du client.

3. Délais de livraison

Les commandes reçues sans indication de date de livraison seront livrées dans le meilleur délai possible. Les délais de livraison qui figurent sur la confirmation de commande le sont à titre indicatif. Les livraisons anticipées et/ou partielles sont considérées autorisées, sauf accord contraire par écrit. Le non-respect des délais pour des raisons de grève, d'échec des négociations, de clôture d'entreprise et les raisons dérivées de ces situations seront considérées de force majeure ne pourront constituer un motif de droit ou de pénalité, ni de dommages et intérêts au bénéfice de l'acheteur. En cas de retard ou de non-paiement, ou si les sommes dues dépassent le montant assuré par notre compagnie d'assurance, les commandes en attente de livraison seront bloquées jusqu'à résolution de la situation.

4. Facturation

Le Groupe STH se réserve le droit d'envoyer et de facturer les commandes du client par le biais des différentes sociétés du Groupe selon la situation de crédit du client. Les données du fournisseur seront indiquées sur le bon de livraison. Aucune modification ne sera admise après expédition.

Le groupe STH utilise un système de communication électronique pour l'envoi des factures.

5. Conditions de paiement

Le financement ne pourra en aucun cas excéder les paramètres définis dans la Loi 15/2010 qui stipule les mesures contre les retards de paiement dans les opérations commerciales. Le non-paiement d'une facture à son échéance entraînera la suspension immédiate de toute autre livraison. Lorsque le Groupe STH accordera au client un délai dans le paiement d'une facture au-delà de la date d'échéance initialement accordée, il sera appliqué une pénalisation de 3% mensuels sur le montant de la facture. En cas de non-paiement, cette pénalisation sera de 5% mensuels, avec un seuil de 15 €, auxquels s'ajouteront 3% mensuels à partir du 2ème mois de retard. Tout paiement reçu sera imputé en premier lieu aux éventuelles pénalisations pour retards ou impayés, puis au montant principal des dettes les plus anciennes, indépendamment du concept indiqué par le client. Toutes les transactions commerciales sont assurées par une compagnie d'assurance-crédit.

6. Retours de marchandise

Toutes les demandes de retour devront être dûment documentées par le client et présenter la facture relative à l'achat, puis analysées et acceptées par le Groupe STH. Les retours de marchandise pour défaut d'identité et/ou de quantité devront être effectués dans les 7 jours suivant la réception du matériel.

Toute autre demande de retour devra être analysée en fonction des critères définis par le groupe STH. Aucun retour de matériel déclassé ou hors garantie ne sera accepté. Les retours acceptés par le Groupe STH seront crédités en leur appliquant une baisse de valeur d'entre 15% et 50% en fonction de l'année d'achat du matériel. Frais de port à la charge du client.

7. Réclamations, garantie et compensation

Conformément aux dispositions légales, en cas de dommage ou d'avarie de la marchandise transportée ou en cas d'incidence sur les quantités, le client devra procéder aux réserves d'usage auprès du transporteur à la réception du matériel ou dans les 24 h. suivantes.

Le groupe STH garantit la robinetterie de ce catalogue pendant 5 ans contre d'éventuels défauts de fabrication.

La garantie pour les cartouches thermostatiques, temporisées et les mécanismes électroniques, ainsi que pour les accessoires (flexibles, douchettes, pommes de douche, barres de douche, etc.) est de 2 ans.

La date d'acquisition devra être dûment justifiée par présentation de la facture d'achat correspondante. La garantie de sera appliquée que dans les cas où le défaut est confirmé par le Département Technique.

Notre garantie ne s'étend pas aux défauts résultant d'un mauvais emploi, d'un montage non conforme aux prescriptions, de négligence dans l'entretien ou dans l'utilisation du produit.

Sont également exclus de la garantie tout dommage lié à la qualité de l'eau.

La garantie couvre l'envoi des produits sans frais, notre responsabilité restant limitée au remplacement ou à la réparation des pièces reconnues défectueuses par le groupe STH, sans aucune indemnisation. Dans le cas où le produit ne soit plus fabriqué, nous nous engageons à livrer un produit similaire de même qualité.

Les cartouches thermostatiques, temporisées et mécanismes électroniques ont une garantie de 2 ans.

Les accessoires (flexibles, douchettes, pommes de douches, supports, barres de douche, etc.) ont une garantie de 2 ans.

Nous nous réservons le droit de modifier le design de nos produits sans avis préalable.

8. Réserve de propriété

Le Groupe STH sera propriétaire des produits livrés au client jusqu'au complet encaissement de la facture correspondante.

9. Responsabilité civile dérivée du produit

Le groupe STH ne peut être considéré responsable que des défauts de qualité internes du produit déjà existants lors de l'expédition au client. Le groupe STH ne peut être tenu pour responsable des dommages dérivés d'un défaut de qualité apparent et qui aurait dû être constaté par le client avant sa revente, son installation ou montage, ainsi que de ceux dérivés d'une erreur d'installation et/ou d'une manipulation de ces produits non conforme aux conditions de montage, de mise en fonctionnement (indiqués dans les instructions de montage) ou des conditions administratives établies.

Les limites de la responsabilité seront appliquées aux acheteurs successifs, avec l'obligation d'être adoptées par tous les futurs acheteurs.

10. Dommages aux destinataires

Dans le cas où le client prenne connaissance de la production de dommages à un destinataire qui pourraient être dérivés des produits (et tout particulièrement en cas de réclamation formelle ou légale de la part du destinataire au client), ce dernier devra le signaler de toute urgence et par écrit au Groupe STH, et lui fournir la preuve desdits dommages ainsi que leur cause et leur estimation, afin de pouvoir établir au mieux les responsabilités et ne pas laisser le Groupe STH sans défense.

Le Groupe STH décline toute responsabilité en cas de réclamation pour dommages relatifs aux produits (provenant d'actions directes ou répétées), si la possibilité de pouvoir évaluer et vérifier la réalité des dommages et leur cause ne lui a pas été donnée.

11. Limitation de la responsabilité civile dérivée du produit

Le montant maximum de l'indemnité qui pourra être assumé par le Groupe STH en matière de responsabilité civile dérivée des dommages causés par ses produits est fixé à 2000 euros.

12. Juridiction

En cas de contentieux dans le cadre de la relation contractuelle entre le Groupe STH et le client, le Tribunal de Barcelone sera seul compétent. La loi espagnole sera la seule applicable.

13. Validité

Ces conditions de vente remplacent toutes les précédentes et resteront en vigueur jusqu'à une nouvelle publication sur www.standardhidraulica.com

NOTAS



NOTAS



Every design, an emotion



@CleverGriferia



GriferiaClever



GriferiaClever

www.griferiaclever.com

sth **COMAP**

Avenida La Ferreria, 73-75 · Pol. Ind. La Ferreria
08110 - Montcada i Reixac · Barcelona - Spain
Tel. +34 93 564 10 94 · info@griferiaclever.com

